

<sup>1</sup> Etienne Alain  
Feukeu

<sup>2</sup> Sumbwanyambe  
Mbuyu

# Design and Implementation of an IoT-Based Induction Motor Protection and Control System Using Arduino and ESP32



**Abstract:** - Induction motors are critical components in both industrial and domestic applications due to their reliability, efficiency, and low maintenance requirements. However, their susceptibility to failures caused by overvoltage, undervoltage, overcurrent, excessive vibration, and temperature extremes necessitates robust monitoring and protection systems. This project proposes an IoT-based induction motor protection and control system that leverages the capabilities of Arduino Nano and ESP32 microcontrollers, along with various sensors, to ensure safe and efficient motor operation. The system continuously monitors key motor parameters such as voltage, current, temperature, vibration, and RPM, and employs a relay to de-energize the motor under fault conditions. Additionally, the system integrates IoT technology, utilizing the ThingSpeak platform for remote monitoring, enabling users to access real-time data and historical logs from anywhere. The proposed system not only enhances motor reliability and lifespan but also reduces energy consumption and operational costs. The design, implementation, and validation of the system are presented, demonstrating its effectiveness in preventing motor failures and optimizing performance.

**Keywords:** Induction Motor Protection, IoT-Based Monitoring, Arduino and ESP32, Real-Time Sensor Data, ThingSpeak Platform.

## I. INTRODUCTION

With the rapid development of technology, induction motors have become ubiquitous in both industrial and domestic applications, playing a key role in modern society. Their widespread use is attributed to their reliability, efficiency, and relatively low maintenance requirements. However, as the reliance on induction motors grows, so does the need for robust control and protection systems to ensure their safe and efficient operation. Without proper monitoring and protection, induction motors are susceptible to failures caused by overvoltage, undervoltage, overcurrent, excessive vibration, and temperature extremes. These failures can lead to costly downtime, increased energy consumption, and even safety hazards.

The integration of advanced technologies, such as microcontrollers and the Internet of Things (IoT), has made it possible to design simple, cost-effective, and efficient induction motor control and protection systems. Development boards like the Arduino and ESP32, which are widely used for prototyping and small-scale projects, have become instrumental in creating such systems. By employing sensors that provide real-time feedback to the Arduino, critical motor characteristics such as voltage, current, temperature, RPM, and vibration can be continuously monitored. Based on these inputs, the Arduino can de-energize the motor and prevent it from starting if any of the motor's operating conditions exceed predefined safe limits. This proactive approach not only enhances the motor's reliability but also extends its lifespan by preventing damage caused by fault conditions.

Furthermore, advancements in remote monitoring technologies, particularly IoT, have made it increasingly desirable to have real-time access to motor conditions from anywhere. By integrating IoT into the system, users can monitor the motor's status remotely using devices such as smartphones or computers. In this project, ThingSpeak, a cloud based IoT platform, is utilized to provide remote monitoring capabilities. The system employs UART (Universal Asynchronous Receiver/Transmitter) communication between the Arduino and ESP32, enabling seamless wireless data transmission to ThingSpeak. This allows users to access real-time data and historical logs, ensuring continuous oversight of the motor's performance even when they are not physically present.

The necessity of such a system is further underscored by studies and industry reports. For instance, the Electric Power Research Institute (EPRI) highlights that motor failures account for a significant portion of industrial downtime, with over 30% of failures attributed to electrical issues such as overvoltage, undervoltage, and overcurrent [1]. Additionally, the International Energy Agency (IEA) emphasizes that inefficient motor operation due to poor monitoring and control can lead to increased energy consumption, contributing to higher operational

<sup>1</sup> \*Corresponding author: University of South Africa (UNISA), Department of Electrical and Smart Systems Engineering, Florida Campus, Johannesburg, South Africa

<sup>2</sup> University of South Africa (UNISA), Department of Electrical and Smart Systems Engineering, Florida Campus, Johannesburg, South Africa

costs and environmental impact [2]. These findings reinforce the importance of implementing comprehensive motor protection systems that not only safeguard the motor but also optimize its performance.

In essence, the proposed induction motor control and protection system leverages the capabilities of Arduino, ESP32, and IoT to provide a cost-effective, reliable, and user-friendly solution. By continuously monitoring key motor parameters and enabling remote access, the system ensures the safe and efficient operation of induction motors, reducing the risk of failure and minimizing energy waste. This project represents a significant step forward in motor protection technology, addressing the growing demand for smarter, more connected systems in an increasingly automated world.

The rest of this work is organized as follows: Section 2 briefly discusses related works on this subject. The proposed design is presented in Section 3. Section 4 presents the test and validation of the proposed design. Finally, the conclusion is drawn in Section 5.

## II. RELATED WORKS

The development of induction motor protection and control systems has been a significant area of research, particularly with the integration of IoT for remote monitoring and control. In one study, the authors developed an induction motor protection system using an Arduino Uno R3 microcontroller and sensors to measure critical parameters such as voltage, current, temperature, and vibration, leveraging ThingSpeak and the Blynk app for remote monitoring, which allowed users to access real-time motor data from any location at any time [3]. The authors highlighted the system's ability to monitor multiple parameters simultaneously, offering a significant advantage over traditional protection techniques by providing a greater number of monitoring fields and enabling remote access through IoT. Another study focused on induction motor control and protection using IoT, employing an Arduino Uno and a TRIAC speed-control circuit to regulate motor speed while monitoring voltage for under- and over-voltage conditions and motor speed wirelessly through the Blynk app [4]. The authors concluded that the system allows for continuous motor monitoring and speed adjustment via the app, with the added capability of sending alert notifications and disconnecting the motor during fault conditions.

Additionally, recent advancements in fault detection techniques, such as motor current signature analysis (MCSA), have been widely considered for their simplicity, availability, and cost-effectiveness. For instance, [5] proposed the use of the normalized frequency domain energy operator (NFDEO) to detect rotor asymmetry faults (RAF) and separate them from load torque oscillations (LTOs), which often lead to false alarms. The study demonstrated that NFDEO, combined with the Wigner–Ville distribution, effectively detects RAF even in the presence of LTOs, both in steady-state and transient conditions, even with speed control strategies. Furthermore, [6] proposed a nonlinear regression framework for modeling composite protection of induction motor loads, addressing the challenge of developing adequate yet not overly complex protection models for aggregate induction motor loads in commercial buildings. The study highlighted the importance of accurate protection modeling for power system planning and operation, especially in understanding dynamic performance and stability post-fault. Another study by [7] explored the application of dynamic state estimation (DSE) for protecting induction motor loads in microgrids, particularly in scenarios involving inverter-interfaced generation. The study emphasized the challenges of traditional time-overcurrent protective devices in such environments and demonstrated the potential of DSE for improving the resilience and reliability of microgrids.

In another study, [8] described the use of IoT to control and monitor induction motors, emphasizing the convenience and efficiency of remote access via Wi-Fi. The system used PZEM-004T sensors to monitor voltage, current, and temperature in real-time, with the Blynk IoT application providing remote monitoring capabilities. The system automatically generated control signals to start or stop the motor if abnormal values were detected, highlighting the importance of early fault detection to improve motor efficiency and ensure safe operation. Similarly, [9] focused on designing a device to detect vibrations in induction motors, which can serve as an indicator of the motor's maximum load limit and provide protection. The study demonstrated that the design could diagnose vibration conditions and monitor the motor through a simple IoT-based control circuit, underscoring the importance of vibration monitoring in maintaining motor performance and preventing failures.

While these studies address specific aspects of motor protection, there is a need for a more comprehensive solution that combines multiple sensors, real-time monitoring, and remote access into a single, user-friendly system. The proposed system builds on these studies by integrating voltage, current, temperature, vibration, and RPM sensors, with data transmitted to a cloud-based platform like ThingSpeak, ensuring continuous oversight and enhancing motor reliability, energy efficiency, and operational safety.

### III. PROPOSED DESIGN

The block diagram of the proposed design is presented in Fig. 1. This figure is made of several components working together to achieve the expected goal. A brief explanation of the working diagram is provided in the next paragraph.

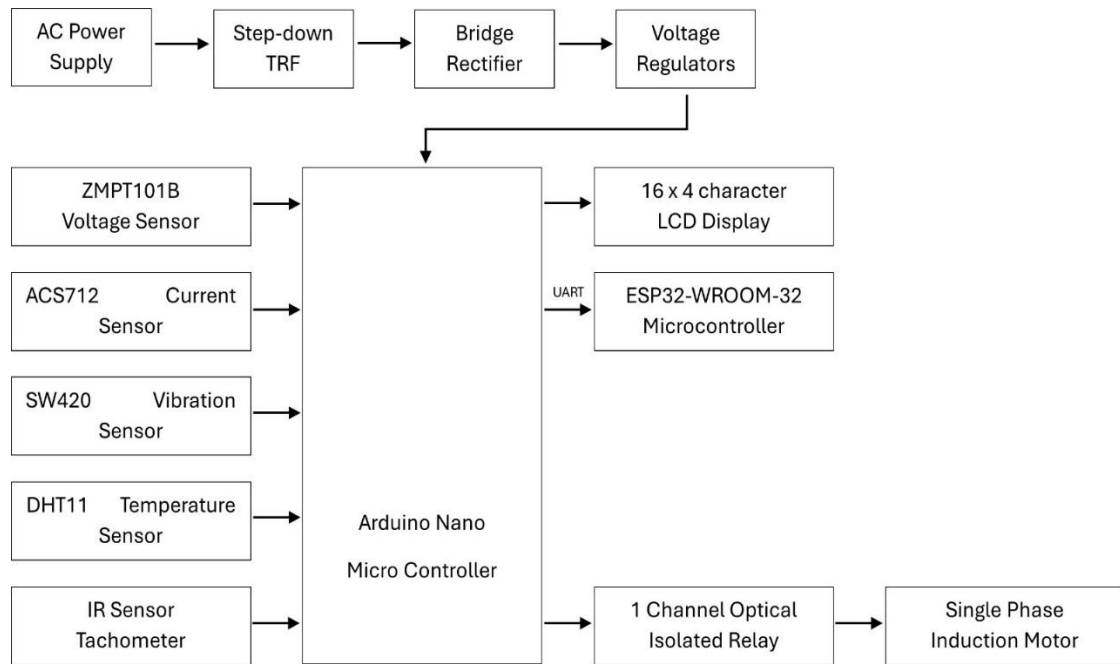

Fig. 1. Block diagram of the proposed system

The system starts with an AC power source which is feed into the Step-down Transformer to Reduces the high AC voltage to a lower level suitable for the system. The Bridge Rectifier is used to Converts the AC voltage to DC voltage and a Voltage Regulators is used to Stabilize the DC voltage to ensure consistent power supply to the components. The Voltage Sensor (ZMPT101B) and the Current Sensor (ACS712) measure the voltage and the current flowing through the induction motor respectively. Similarly, the vibration sensor (SW420), the temperature sensor (DHT11) and the tachometer sensor measure the vibration, the temperature, and the rpm speed rotation of the induction motor respectively and feed all gathered information in the Arduino microcontroller. The microcontroller process all received information and display relevant details on the LCD display. Additionally, all recorded information is are transferred online on the ThingSpeak platform via the WiFi and Bluetooth module (ESP32-WROOM-32) which can be assessed from anywhere in the world.

In brief, the system monitors the induction motor's voltage, current, temperature, vibration, and speed using various sensors. The microcontrollers process this data, display it on the LCD, and control the motor via the relay. This setup ensures the motor operates within safe parameters and provides real-time feedback to the user.

A brief overview of all main components is described in following paragraphs.



Fig. 2. Arduino Nano



Fig. 3. ESP32-WROOM-32



Fig. 4. ZMPT101B Voltage sensor

**Arduino Nano:** Fig. 2 shows an Arduino Nano which forms part of the Arduino family. The Nano is a small compact microcontroller that offer 20m Digital, 9 Analog and 6 PWM outputs [10]. The nano will process the real-world data received from the sensors and control the motor based on pre-determined parameters that forms part of the sketch. It will display the required data on the LCD and send them to the ESP32 through UART functionality.

**Esp32-Wroom-32:** Fig. 3 show an ESP32-WROOM-32 microcontroller that is used for the wireless communication with ThingSpeak. The ESP32 family is a powerful set of microcontrollers that offers 32 General purpose Input/Output (GPIO) pins. The ESP32-WROOM-32 itself offers WiFi and Bluetooth functionality with the WiFi reaching up to 150Mbps [11].

**Voltage Sensor(ZMPT101B):** Fig. 4 shows a ZMPT101B voltage sensor module that will be used to measure the supply voltage of the system. The ZMPT101B voltage sensor is a highly accurate sensor that can measure Alternating current voltage up to 1000Vac [12].

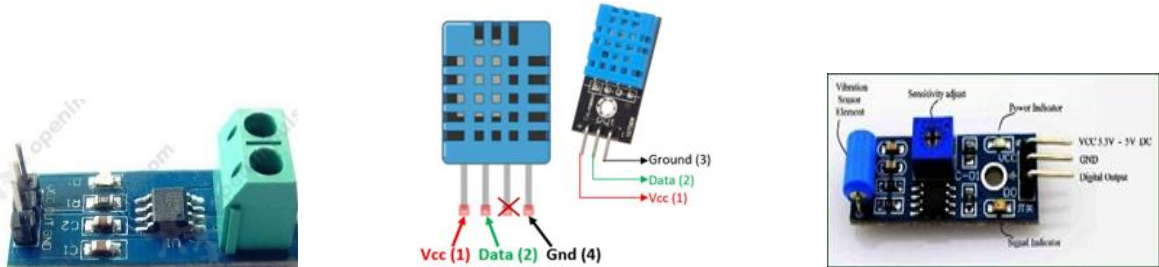

Fig. 5. ACS712 hall current sensor Fig. 6. Temperature and Humidity sensor Fig. 7. SW420 Vibration sensor

**Current Sensor:** Fig. 5 shows an ACS712 hall current sensor that will be used to measure the current consumption of the induction motor. The ACS712 uses the hall effect method to measure the current consumption and can in some modules measure up to 30A of current. The ACS712 is an accurate sensor with an output error of approximately 1.5% [13].

**Temperature sensor (DHT11):** Fig. 6 shows a DHT11 sensor that will be used to monitor the ambient temperature around the induction motor during operation. Although the sensor has the capabilities to measure humidity it will only be used for temperature. The DHT11 sensor has a temperature range of 0-50°C and an accuracy level of approximately 2°C [14].

**Vibrator Sensor (SW420):** Fig. 7 shows a SW420 Vibration sensor that will be used to monitor the induction motor for any excessive vibration that can be caused by a loose bolt of misalignment. The vibration sensor is equipped with an adjustable pot to adjust the sensitivity of the sensor and will provide a digital high to the Arduino Nano when vibration is detected [15].



Fig. 8. IR sensor



Fig. 9. 1 Channel optical isolated relay

**IR Sensor:** Fig. 8 shows an IR sensor module that will be used as a Tachometer to measure the rpm of the induction motor. The IR sensor has the capability to measure 2-10cm which enable it to be placed at a safe distance from the motor shaft during operation. The IR sensor will be used to measure reflection from the motor shaft and count the rotation of the shaft per minute [16].

**Channel Optical Isolated Relay:** Fig. 9 shows a 1 channel optical isolated relay that will be used to control the motor. Depending on the signal level received from the Arduino Nano the relay will either energize or de-energize the motor. The relay physically separated the AC power from the circuit with the use of an optical signal that is used to switch the contact of the relay. This reduces the risk of the high voltage AC power which can affect the Arduino or sensors that are designed to operate at low DC voltages [17]. The relay also has the capability of handling load current of up to 10A at a rated voltage of 250Vac.

The complete circuit diagram is depicted in Fig.10.

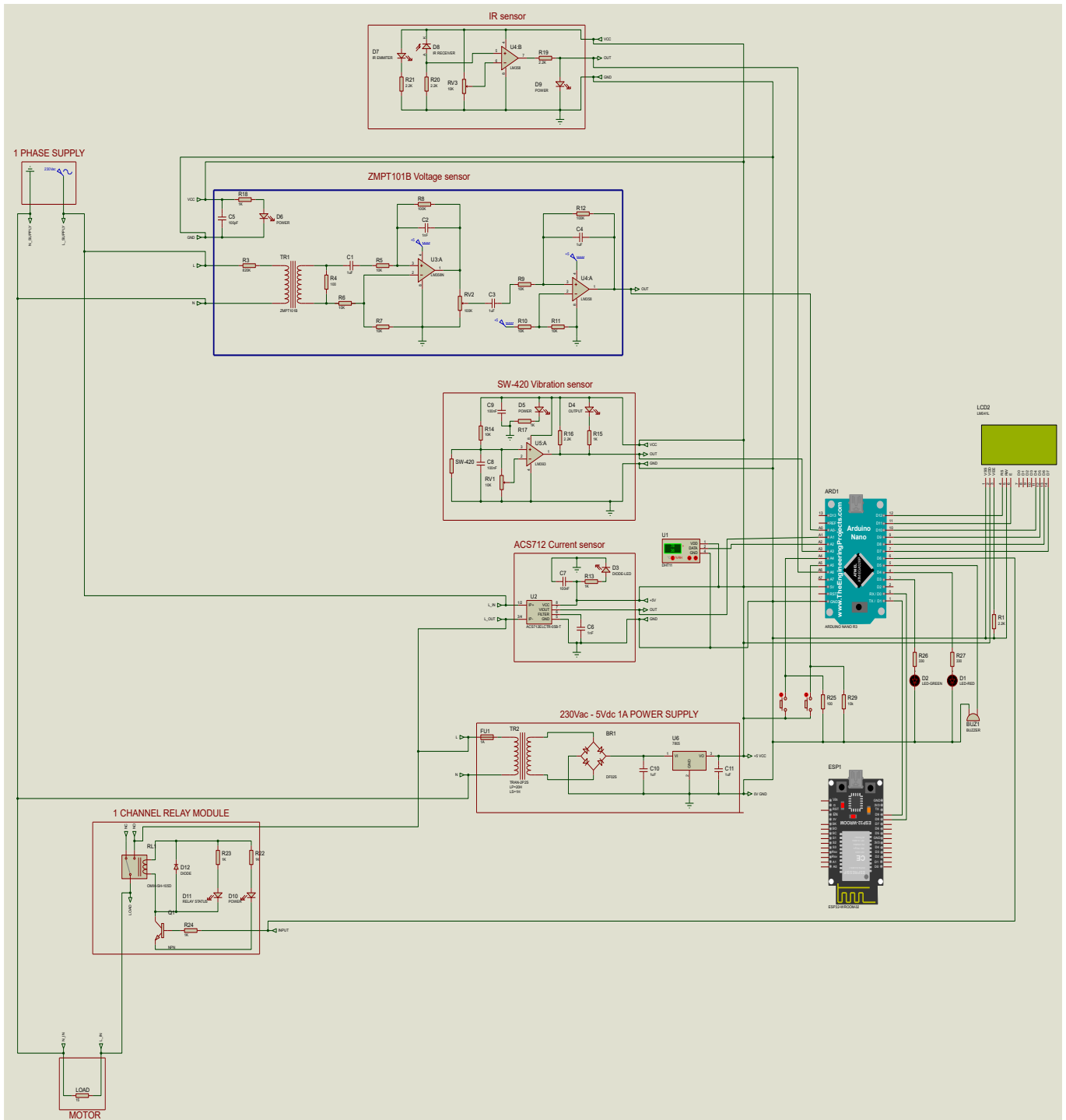

Fig. 10. Complete circuit diagram

Fig. 10 present the complete circuit diagram of the proposed system. This circuit was implemented in the breadboard and evaluated accordingly. The developed and tested prototype is presented in the next section.

## IV. PROPOSED DESIGN TEST AND VALIDATION

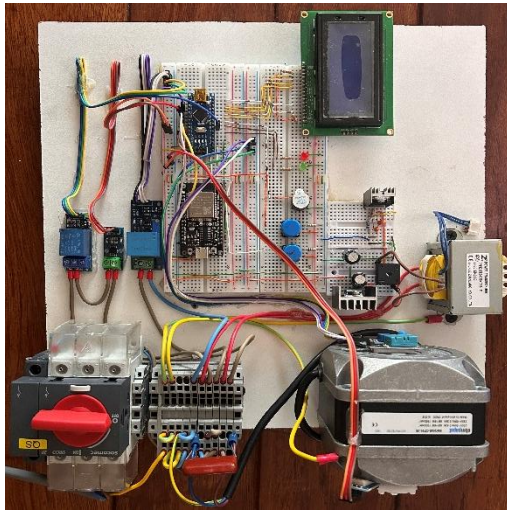

Fig. 6. Hardware setup

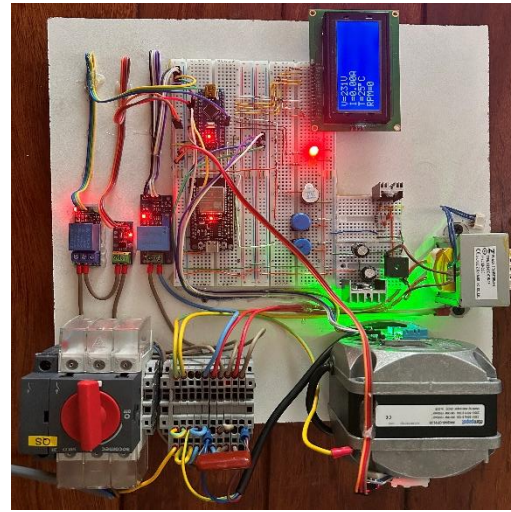

Fig. 7. Motor de-energized

Fig. 11 shows the hardware setup for the final system that has been designed and implemented. The system is designed in such a way that it can safely isolate the 220Vac supply when not in use with terminals installed to prevent accidental contact with the supply power. After implementation was completed the induction motor protection and control system was initially energized and test according to the different characteristics that was set out to be achieved. The following results was obtained at different stage of operations.

#### A. Normal Condition

Normal conditions are defined as when the system is operational without any faults detected. This will include when the motor is de-energized and when the motor is energized.

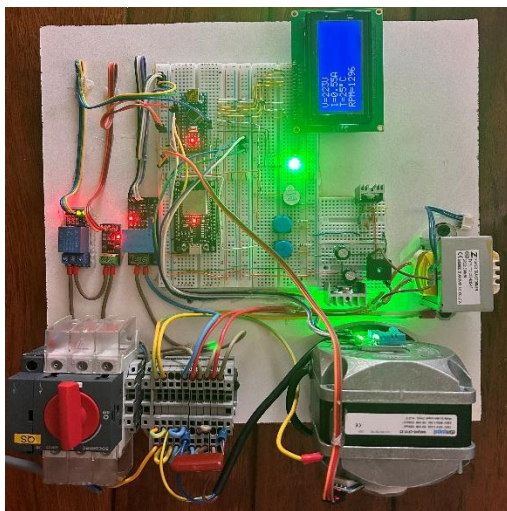

Fig. 8. Motor energized.

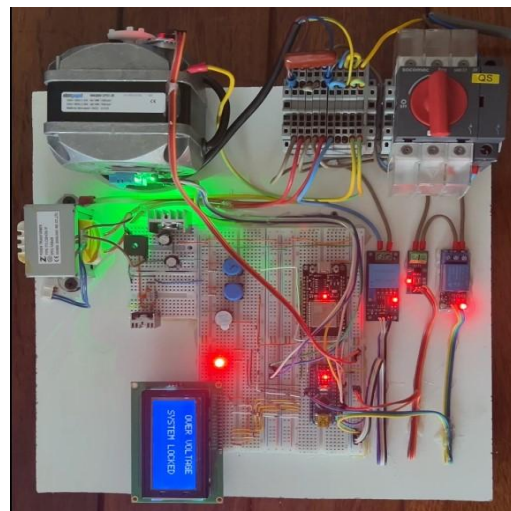

Fig. 9. LCD display during over voltage conditions

From Fig. 12 and Fig. 13, it can be seen that the system provides visual indication when the motor is energized and when de-energized. The LCD screen also provide continuous real time data of the characteristics of the motor.

#### B. Over Voltage

When the supply voltage increases to a point where it will be capable of causing damage to the induction motor the system de-energizes the motor and provide feedback on the LCD to indicate that over voltage have been detected and the system is locked out. In Fig. 14 the feedback from the LCD can be seen when an over voltage fault occurs.

*C. Under Voltage*

In the case where the supply voltage drops down to a point where it can cause damage to the induction motor the system will de-energize the motor and enter lockout mode to prevent it from starting up during this condition. Fig. 15 shows the LCD display during under voltage conditions.

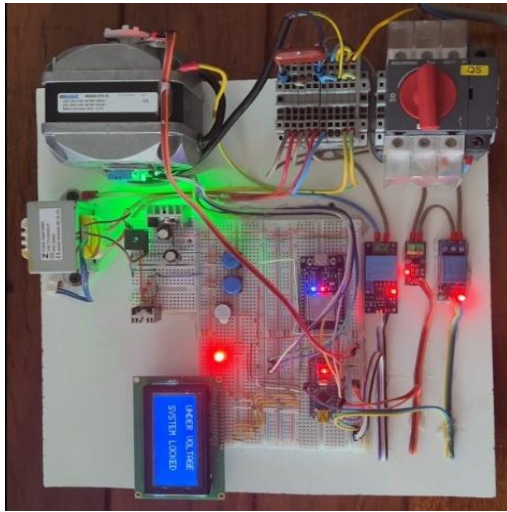

Fig. 10. Test of the under-voltage conditions

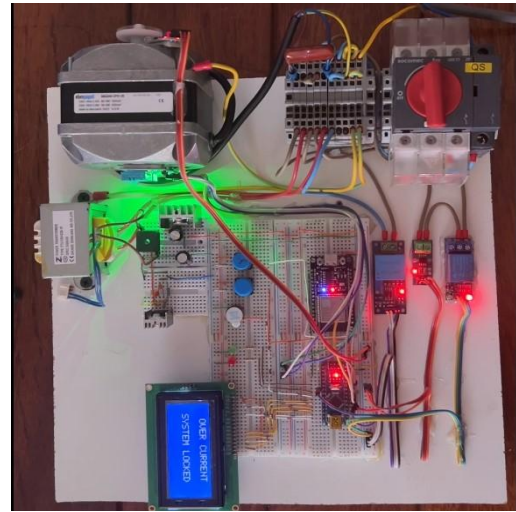

Fig. 11. Test of the over current conditions

*D. Over Current*

During conditions where the load on the motor shaft have increase to a point where the current consumed by the motor increases to a point where it can cause damage to the motor the system will enter over current condition mode. The motor will de-energize and reset the system. Fig. 16 shows the LCD display output during over current conditions.

*E. Over Temperature*

The temperature of the motor has a direct effect on the motor. If the temperature increases to a point where the efficiency of the motor is affected the system will de-energize the motor and display on the LCD that over temperature conditions have been detected. Fig. 17 shows the display on the LCD during over temperature conditions.

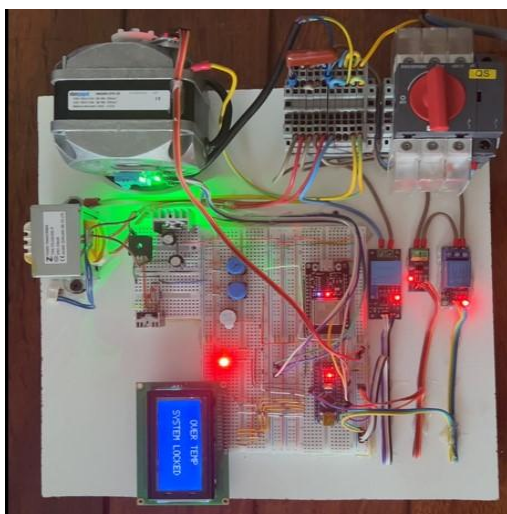

Fig. 12. Test of the over temperature conditions

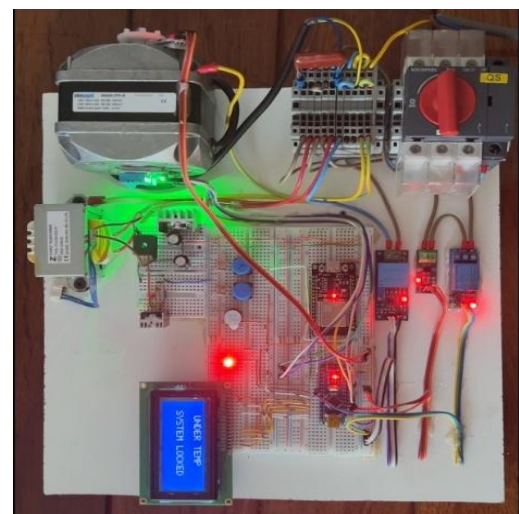

Fig. 13. Test of the under-temperature conditions

*F. Under Temperature*

When the ambient temperature around the motor decrease to a point where it will cause the metal casing to start contracting the system will detect the fault as under temperature. During these conditions the motor will be de-energized and lockout out to prevent the motor from starting up. Fig. 18 shows the display output on the LCD during under temperature conditions.

*G. Vibration Detection*

Excessive vibration on the motor can be due to a loose bolt on the base of the motor or misalignment of the motor shaft with the load. These cases can cause damage to the motor and in some cases cause catastrophic failure of the motor. If excessive vibration is detected by the system, the motor will be de-energized and locked out to prevent startup of the motor during these conditions. Fig. 19 below shows the LCD display output during these conditions.

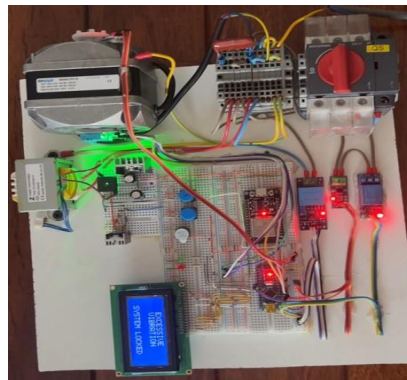

Fig. 14. Test of the excessive vibration conditions.

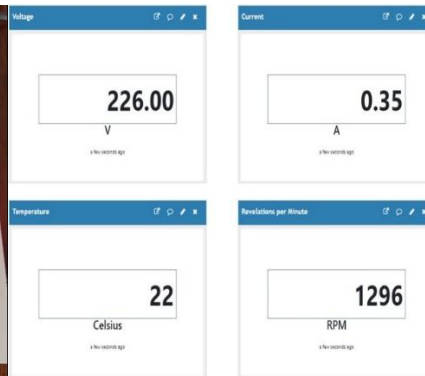

Fig. 15. ThingSpeak display information online.

*H. ThingSpeak IoT Output Results*

All the measured data captured by the sensors are transferred to a ThingSpeak platform that can be accessed either by a personal computer or by a mobile device. Real time data is displayed on the personal computer as shown by Fig. 20 and can be accessed by the user at any time. The mobile device application for ThingSpeak is used for historical data. This mobile application on ThingSpeak can be set to display historical data from the last 10min to the last 24 hours. This can assist with fault finding or maintenance of the induction motor. Fig. 21 shows the historical data for the motor over a 1-hour period.

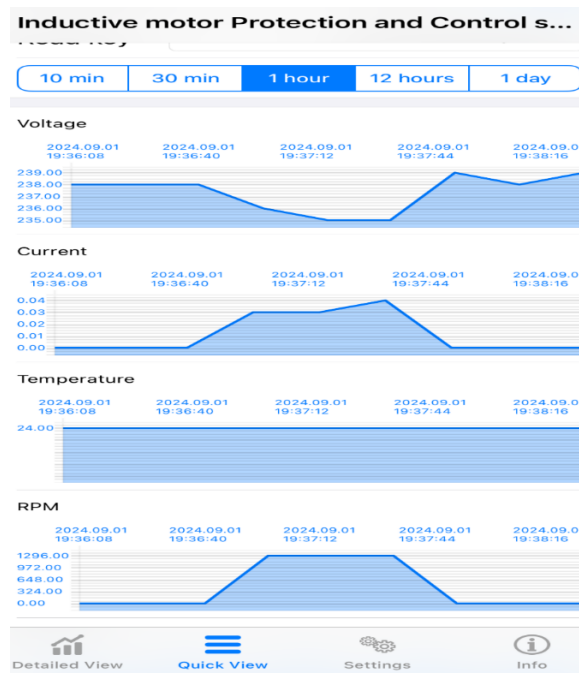

Fig. 16. ThingSpeak platform record over a mobile device.

## V. CONCLUSION

The proposed IoT-based induction motor protection and control system represents a significant advancement in motor monitoring and protection technology. By integrating Arduino Nano and ESP32 microcontrollers with a suite of sensors, the system provides real-time monitoring of critical motor parameters such as voltage, current, temperature, vibration, and RPM. The system's ability to de-energize the motor under fault conditions, such as overvoltage, undervoltage, overcurrent, excessive vibration, and temperature extremes, ensures safe and efficient operation, reducing the risk of costly downtime and energy waste.

The integration of IoT technology, through the ThingSpeak platform, allows for remote monitoring and access to real-time data and historical logs, providing users with continuous oversight of the motor's performance. This feature is particularly valuable in industrial settings where remote monitoring can significantly enhance operational efficiency and reduce maintenance costs.

The system's design and implementation have been validated through rigorous testing, demonstrating its effectiveness in detecting and responding to various fault conditions. The results show that the system can reliably protect induction motors from damage caused by electrical and mechanical faults, while also optimizing their performance and energy efficiency.

## VI. ACKNOWLEDGMENT

We would like to thank all team members for this experiment and address a special thanks to Kyle Pretorius for his positive contribution toward this work and UNISA (University of South Africa) for its continuous support.

## REFERENCES

- [1] S. Kumar et al., "A Comprehensive Review of Condition Based Prognostic Maintenance (CBPM) for Induction Motor," in *IEEE Access*, vol. 7, pp. 90690-90704, 2019, doi: 10.1109/ACCESS.2019.2926527.
- [2] IEA/4E TCP (2021), Achievements of Energy Efficiency Appliance and Equipment Standards and Labelling Programmes, IEA, Paris (2021), License: Creative Commons Attribution CC BY-SA 3.0 IGO <https://www.iea.org/reports/achievements-of-energy-efficiency-appliance-and-equipment-standards-and-labelling-programmes>, Licence: CC BY 4.0.
- [3] S. Kambale, K. Patel, V. Mali, K. Bargale, A. Tawade and R. L. Patil, "Induction motor protection system and data monitoring over IOT blynk," *International Research Journal of Modernization in Engineering technology and Science*, vol. 04, no. 07, p. 7, 2022.
- [4] Digvijay B Kanase; Sukhada B. Dombale; Pratik V. Deshmukh; Pankaj G. Landge; Pratik B. Patil. "Induction Motor Control and Protection Using IOT." Volume. Volume. 7 Issue. 5, May - 2022 , *International Journal of Innovative Science and Research Technology (IJISRT)*, [www.ijisrt.com](http://www.ijisrt.com). ISSN - 2456-2165, PP :- 450-455. <https://doi.org/10.5281/zenodo.6609398>.
- [5] R. Bazghandi, M. H. Marzebali and V. Abolghasemi, "Asymmetrical Fault Detection in Induction Motors Through Elimination of Load Torque Oscillations Effects in the Slight Speed Variations and Steady-State Conditions," in *IEEE Journal of Emerging and Selected Topics in Industrial Electronics*, vol. 4, no. 3, pp. 725-733, July 2023, doi: 10.1109/JESTIE.2022.3204485.
- [6] S. Kundu et al., "A Nonlinear Regression Method for Composite Protection Modeling of Induction Motor Loads," 2020 IEEE Power & Energy Society Innovative Smart Grid Technologies Conference (ISGT), Washington, DC, USA, 2020, pp. 1-5, doi: 10.1109/ISGT45199.2020.9087795.
- [7] A. K. Barnes, S. Basu and A. Mate, "Dynamic State Estimation-Based Protection for Induction Motor Loads," 2022 North American Power Symposium (NAPS), Salt Lake City, UT, USA, 2022, pp. 1-5, doi: 10.1109/NAPS56150.2022.10012235.
- [8] Ridho Syawali, Selamat Meliala, "IoT-Based Three-Phase Induction Motor Monitoring System," *Journal of Renewable Energy, Electrical, and Computer Engineering (JREECE)*, Vol. 3, No. 1, (2023). DOI: 10.29103/jreece.v3i1.9811.
- [9] B. Artono, A. Susanto, and N. A. Hidayatullah, "Design of Smart Device for Induction Motor Condition Monitoring," *Journal of Physics: Conference Series*, vol. 1845, no. 1, pp. 012035, Mar. 2021, doi: 10.1088/1742-6596/1845/1/012035.
- [10] Arduino Nano, "Nano". Accessed: Feb. 25, 2025. [Online]. Available: <https://docs.arduino.cc/hardware/nano/#tech-specs>.
- [11] Samuel Adesola, "How to set up ESP32-WROOM-32". Accessed: Feb. 25, 2025. [Online]. Available: <https://samueladesola.medium.com/how-to-set-up-esp32-wroom-32-b2100060470c>.
- [12] Microrobotics, "AC Voltage Sensor 220V, Analog Ratio Output". Accessed: Feb. 25, 2025. [Online]. Available: <https://www.robotics.org.za/ZMPT101B>.
- [13] Miguel Gudino, "Product Insight: Allegro's ACS712 Hall-Effect Current Sensor IC". Accessed: Feb. 25, 2025. [Online]. Available: <https://www.arrow.com/en/research-and-events/articles/product-insight-allegros-ac712-hall-effect-current-sensor-ic>.
- [14] Mousser Electronics, "DHT11–Temperature and Humidity Sensor". Accessed: Feb. 25, 2025. [Online]. Available: <https://components101.com/sensors/dht11-temperature-sensor>.

- [15] Communica, “Hkd Sw-420 Vibration Module”. Accessed: Feb. 25, 2025. [Online]. Available: <https://www.communica.co.za/products/hkd-sw-420-vibration-module>.
- [16] Arduino Team, “Build your own tachometer with an IR sensor and an Arduino”. Accessed: Feb. 25, 2025. [Online]. Available: <https://blog.arduino.cc/2023/04/25/build-your-own-tachometer-with-an-ir-sensor-and-an-arduino/>.
- [17] Make Electronics, “1-Channel 5VDC Relay Module Type 1”. Accessed: Feb. 25, 2025. [Online]. Available: [https://make.net.za/product/1-channel-5vdc-relay-module-type1/?gad\\_source=1&gclid=EAIaIQobChMImPrFu-neiwMVeQVQBh16CzI8EAQYBSABEgLHx\\_D\\_BwE](https://make.net.za/product/1-channel-5vdc-relay-module-type1/?gad_source=1&gclid=EAIaIQobChMImPrFu-neiwMVeQVQBh16CzI8EAQYBSABEgLHx_D_BwE).