

Mahendra Annaji Bagde^{1*}
 Dr. Anjali U. Jawadekar²
 Priti Mahendra Bagde³

Enhanced Energy Management Techniques For Fuel Cell/Battery/Ultracapacitor Hybrid Electric Vehicle Based On Different Control Strategy



Abstract:

The hybrid electric vehicle's power management strategy (PMS) and fuel efficiency are closely related (HEV). In this paper, an adaptive neuro-fuzzy inference approach and a hybrid power management strategy are developed (ANFIS). A significant advancement in controlling electricity across multiple energy sources is artificial intelligence (AI). A proton exchange membrane fuel cell (PEMFC) serves as the major energy source in the hybrid power supply, with a battery bank and an ultracapacitor serving as electric storage systems. The stress on each energy source is calculated using the Haar wavelet transform technique. Simulink and MATLAB are used to create the suggested model. The results of the simulation show that the suggested plan is able to meet the power requirements of a typical driving cycle. Evaluations of the various PMS have been done based on their power consumption, overall efficacy, ultracapacitor and battery state of charge, stress placed on hybrid power sources, and stability of the DC bus.

Keywords: ANFIS; ECMS; a hybrid electric vehicle; Haar wavelet transform; hydrogen consumption; power management scheme; system efficiency.

I. INTRODUCTION

Freshwater, electricity and the atmosphere are interconnected factors that have emerged as the most significant and prominent topics in engineering. In particular, global warming and resource shortages are key challenges that have been addressed. As a result, manufacturing practices and engineering communities are rapidly transforming the approach to energy-efficient applications; environmental and economic considerations are driving the transportation sector's development [1]. Transportation is mostly reliant on fossil fuels and produces greenhouse gases. Here, several attempts have been made to enhance the requirement of fuel cells (FCs) in transportation applications as a sustainable electric power source that emits no greenhouse gas [2]. The usage of fuel cells in electric vehicles, trains, aircraft, etc., helps to protect the environment, thereby providing a clean fuel source for transportation [3]. Fuel cells are new energy conversion solutions that have many advantages over traditional devices, including high energy efficiency, small size, environmental safety, long lifespan and so on. The proton exchange membrane fuel cell (PEMFC) seems to be the most suitable form for use in automotive applications because it has a high density in producing electricity, leading to lower heat generation and resulting in a lower temperature, which is important in transportation applications. The key drawback of fuel cells in transportation applications is the low dynamic response. Since the fuel cell lags against load variations, this means that they are unable to react appropriately to sudden changes in load.

As a result, the fuel cell should be associated with the battery storage and ultracapacitor (UC) [4], while the battery storage seems to have a high-power density, with some limitations, such as lower energy capacity, a long charging period, a high price and a short lifespan. The usage of a hybrid FC/B/UC network is the best strategy to overcome the described issues. This type of combination allows the hybrid sources to exploit their unique characteristics. The battery bank acts as an energy buffer, whereas the ultracapacitor supplies transient peak power units. A power management scheme (PMS) is essential to achieve certain hybridization and achieve the main goal of distributing load requirements through power sources. By limiting the fuel cell performance to wider operating levels, the PMS successfully maintains the consumption of hydrogen and enhances the energy efficiency. To regulate the system load among these integrated input sources, a set of conventional PMS was implemented [5].

They are PI control, state machine control (SMC), the equivalent consumption minimization scheme (ECMS), fuzzy logic control (FLC) and the external energy minimization scheme (EEMS), and several other modern optimization-based techniques have also been developed. In [6], Wang et al. developed a power management technique for state machine control (SMC) that contains the battery bank, fuel cell and ultracapacitors as a multi-input network. In [7], power management with the proportional integral (PI) technique was implemented by the authors to regulate the energy across photovoltaics (PV), fuel cells (FCs), batteries and supercapacitors (SCs). Multiple operational modes were operated for a hybrid device consisting of B/SC/FC in [8] using a rule-based energy management technique. In Ref. [9], Jiang et al. proposed a dynamic programming (DP) method for reducing hydrogen consumption in a hybrid power system with a fuel cell, battery and supercapacitor to provide energy to the power train. In [10] implemented a novel power management technique with rule-based fuzzy logic control with various multi-input sources, i.e., at first, the input sources consist of FC/B, and, later, the input sources consist of B/SC/FC for powering an electric vehicle.

¹Research Scholar, Shri Sant Gajanan Maharaj College of Engineering, Khamgaon Road, Shegaon, India. mabagde@gmail.com

²Associate Professor, Shri Sant Gajanan Maharaj College of Engineering, Khamgaon Road, Shegaon, India, anjali.jawdekar@gmail.com

³MTech CSE, RGPV University Bhopal, pmbagde020785@gmail.com

In [11], the authors present an adaptive neuro-fuzzy inference system (ANFIS) to adequately manage the power between the FC and battery often used to provide power to electric vehicles (EV). In [12], proposed a power management technique divided into two sections, a wavelet-based and a radial-based solution, to refine the power output in an electric vehicle using neural networks. The authors designed a novel energy management mechanism focusing on wavelet transform approaches for controlling power among FC/B/SC to EVs. A Gray Wolf Optimizer (GWO) was designed by authors Djerioui et al. considering FC/B/UC as a hybrid power system for electric vehicle applications [13]. In a parallel HEV, an FLC-based technique was designed to optimize the SoC, enhance fuel efficiency, minimize NO_x emissions and ensure greater drivability. For power split across accessible sources, an FLC-based intelligent energy management agent (IEMA) has been developed. In [14] created an FLC to optimize system operation using the energy demands and the speed of the vehicle, as well as the SoC, as input variables.

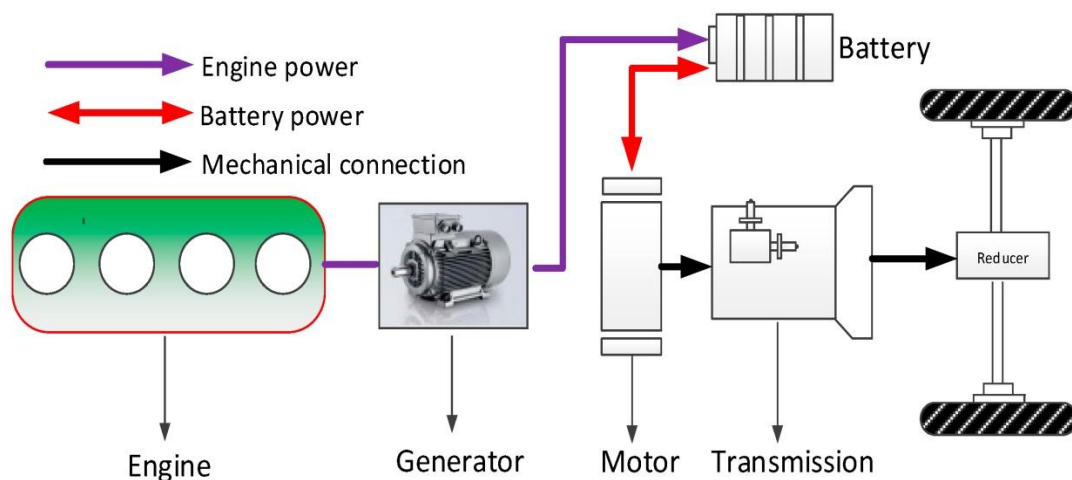

Figure 1. Conventional diagram of Hybrid E-Vehicle

Various energy management solutions for EVs driven by FC are reported in [15]. Bizon et al. suggested a new optimization approach based on a two-dimensional mechanism that characterizes the fuel economy of hybrid vehicles. In [16], combined the fuzzy logic and wavelet transformation approaches to optimize the energy management of hybrid tramways. The research's primary feature is the development of an optimal EMS for minimizing the hydrogen demand and loss of FC functionality. None of the individual algorithms completely address all optimization challenges. This is in line with the No Free Lunch Scientific Theory, discussed in [17], which signifies that novel optimization algorithms are indeed required in the field of research in the power management of EVs. Measuring hydrogen consumption with a hybrid energy storage system to the DC voltage bus is a key issue that might be addressed. It also consolidates all DC/DC converters into a single unit. This research work describes a novel hybrid energy management system that integrates an adaptive neuro-fuzzy inference system (ANFIS) and functions as an adaptive control system. Regarding cost and lifespan cycle maintenance, this control system is simulated with MATLAB/Simulink software to reduce hydrogen utilization in the FC, as well as to maintain the battery levels (SoC percent) as high as possible. A hybrid power management scheme is proposed for better fuel economy in a hybrid electric vehicle using FC/B/UC and PMS configurations, as illustrated in Figure 1.

The paper is structured as follows. Section 2 discussed the literature survey as a various problem statements. Section 3 presents the proposed power management strategy (ANFIS) methodology. Section 4 shows the comparison results analysis with proposed methodology. Finally, the Section 5 presents the main conclusions that were obtained from the realization of this proposed work.

II. LITERATURE SURVEY

The fuel-cell–battery, fuel-cell–ultracapacitor, and fuel-cell– battery–ultracapacitor vehicles were modeled in MATLAB/Simulink. For a good tradeoff between accuracy and run-time, modeling details were included when they significantly affected the optimization goals (e.g., in precise modeling of the dc/dc converters) and were omitted otherwise (e.g., in simplified modeling of the motor). A qualitative analysis was performed to determine the best powertrain topologies for use in this paper, based on efficiency, mass, and cost. Fig. 1 shows the chosen powertrain topologies. All three vehicle types use a dc/dc converter to boost the output voltage of the fuel cell to match the motor-controller input voltage (250–400 V is a common range [18]). This design is advantageous because it allows a smaller, and hence less costly, fuel cell to be used, since the fuel-cell output voltage can be below 250 V. Since the ESS is connected directly to the high-voltage bus (except for the battery in the fuel-cell– battery–ultracapacitor vehicle), the number of battery or ultracapacitor cells in series is constrained. This is an acceptable restriction, since the alternative of using another DC/DC converter for the ESS adds to the vehicle mass and cost and reduces system efficiency.

2.1. Batteries

Lithium-ion batteries are now generally accepted as the optimal choice for energy storage in electric vehicles over lead-acid or nickel-metal-hydride batteries due to their superior power and energy densities [6]. The battery model used in this paper is based on A123 Systems' new high-power lithiumion ANR26650MI cell [1], which shows high power density, high efficiency, and low cost as compared to batteries used in previous vehicle studies [20, 21]. The two variables, the number of cells in series (batt_s) and in parallel (batt_p), determine the total resistance and %V –SOC curves. Similar to the fuel-cell model, the %V –SOC curve is a function of the percentage of maximum voltage so that the same curve can be used for different numbers of cells in series. The coulombic efficiency is estimated at 95% [22].

The battery current is measured and multiplied by the battery voltage. This power is integrated and then converted from joules to kilowatt hours, so that the energy into or out of the battery can be added to the initial energy in the battery (in kilowatt hours). The instantaneous amount of energy in the battery is then divided by the total battery capacity to get the battery SOC in percent. The lookup table converts this %SOC to voltage, based on the data for the ANR26650MI cell [23]. For the battery ESS, the number of battery cells in series is constant at 105, since at 3.3 V/cell, this gives a nominal bus voltage of 346.5 V (with room to charge and discharge without violating the motor–controller voltage limits). For the battery–ultracapacitor ESS, a two-quadrant dc/dc converter is used between the battery and the high-voltage bus, and the battery voltage is chosen to be lower than the bus voltage. In order to allow the ultracapacitor bank to reach 250 V while discharging, the upper limit for the number of battery cells in series is 75. Each cell has a mass of 70 g. After adding 53 g for cell balancing and packaging, the total mass is 123 g/cell. The published cost for six cells is \$110 [24]. For higher volume production, it is assumed the cost could be reduced to \$100. Finally, \$15 is added to each group of six cells for cell balancing and packaging. Thus, the cost of each cell is estimated at \$19.15. The upper current limit is 70 A, and the per-kilowatt cost is estimated at \$82.90/kW.

2.2. Fuel Cell Model

The DC/DC converters connected to the fuel cell and battery are crucial powertrain components, as they allow the fuel-cell and battery voltage to vary independently of the ultracapacitor voltage. A nonisolated DC/DC converter is suitable for use in fuel-cell vehicles when isolation is not required (which is assumed in this paper) and when the voltage boost is not too high (which is true in this paper) [25]. Thus, the simple bidirectional converter (shown in Fig. 5) is used to connect the battery to the high-voltage bus in the fuel-cell–battery–ultracapacitor vehicle and the simple unidirectional boost converter (converter in Fig. 5 with switch S1 removed to ensure unidirectional power flow) is used to boost the fuel-cell voltage for all vehicle types. Although it is common practice to use interleaved and/or soft-switched [26] converters at these high power levels, this paper uses models of the basic hard-switched converters to simplify the modeling and to avoid the in-depth topic of comparing various soft-switching methods based on efficiency, complexity, ease of control, mass, and cost.

It is important to use an accurate DC/DC converter model, because the dynamic converter losses will have an effect on the overall vehicle fuel economy [27] and a high-power converter can add significant mass and cost to the powertrain. For example, to determine the actual advantage of using a smaller fuel cell or battery, the fact that the associated DC/DC converter will be lighter and cheaper must be taken into account.

2.3. Ultracapacitor Vehicle

In an ultracapacitor vehicle, the ultracapacitor stores regenerative braking energy and provides extra power during accelerations. There is generally insufficient energy storage available in the ultracapacitor to propel the vehicle at low speeds. Therefore, the control strategy must ensure that the available energy-storage capacity is utilized in the best way. In [28] compares three strategies and shows that keeping the sum of the kinetic energy of the vehicle and the energy stored in the ultracapacitor constant gives the best fuel economy. This makes sense intuitively since when the vehicle velocity is high, the ultracapacitor voltage will be low, and thus, it will have sufficient room to accept regenerative braking energy when the vehicle brakes. The controller variable is again chosen as the low-pass filter coefficient τ . The filter is used to divide the desired electrical power into fuel cell and ESS power. The ultracapacitor provides all of the ESS (transient) power within its current and voltage limits. If the ultracapacitor voltage reaches the lower limit (250 V), the battery provides the remaining power required. The battery also provides power if the fuel cell cannot meet its power request and if the fuel-cell current request is below 7.55%.

III. PROPOSED HYBRID POWER MANAGEMENT SYSTEM

A hybrid energy storage system (HESS) is a combination of PEMFC, Li-ion batteries and a supercapacitor. These three sources are often considered as an FCHEV to ensure reliable power sufficiency of the load. The configuration of the hybrid system analysis can be seen in Figure 1. The fuel cell and rechargeable battery, as well as capacitors, are the three sources of power in this setup. A DC/DC boost converter has been used with the fuel cell to enhance its voltage level towards the desired level and sustain this at the outputs. There are batteries, where a DC/DC bidirectional power device converts variable power to a fixed voltage. Supercapacitors, similarly to some other capacitors, have been integrated into bidirectional converters, which enable power to be exchanged in both directions.

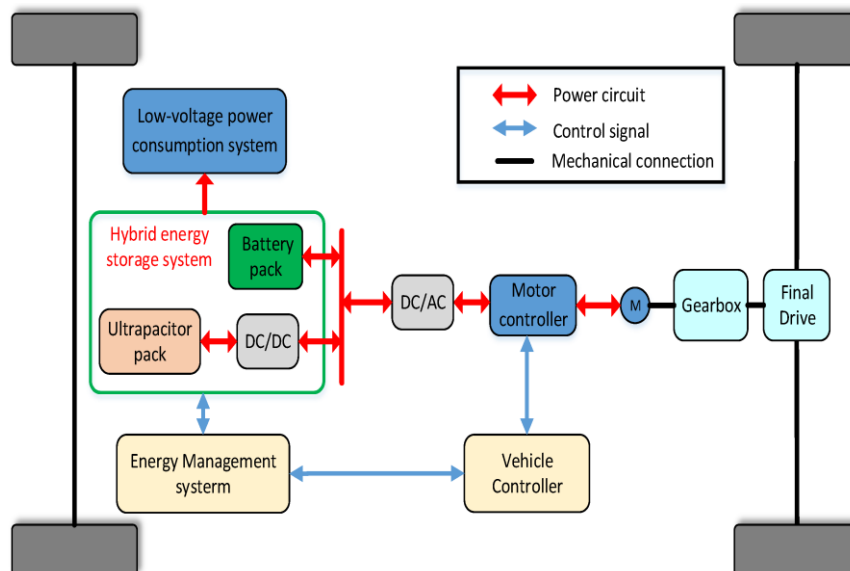

Figure 2. Proposed Hybrid Power Management System

3.1. Fuel Cell

There are several types of fuel cell technology, which are categorized depending upon their electrolytes. Another type of fuel cell that is widely used in vehicular applications is the proton exchange membrane fuel cell (PEMFC). There are several new fuel cell prototypes, each with a combination of benefits and drawbacks based on the topic under study. Any model must be concise and accurate. Furthermore, this paper presents a simple electrochemical concept that might be used to determine the behavior of such a fuel cell both in dynamic and static conditions [29]. The hydrogen fuel design used in this study is based on the interaction between both the fuel cell voltage level and hydrogen, water, plus oxygen absolute pressures. The specifications of the fuel cell stack are illustrated in Table 1. The fuel cell voltage is regulated via oxygen and hydrogen relative pressures, the chemical process temperature of membrane hydration and also the output current. The mathematical model is given bellow.

$$V_{FC} = E_{Nernst} - V_{act} - V_{ohmic} - V_{con} \quad (1)$$

Where E_{Nernst} represents the mean value of thermodynamic potential in every single cell unit.

Here,

V_{act} = Activation voltage drop,

V_{ohmic} = Ohmic voltage drop,

V_{con} = Concentration voltage drop.

Hence, for N number of cells connected in series, the stack voltage V_{stack} is described as

$$V_{stack} = N \cdot V_{FC} \quad (2)$$

Table 1. Fuel Cell Specifications

Fuel Cell Model (Input Parameters)	Specifications
Voltage	53.5V
Number of Fuel Cell	65
Operating temprature	43°C
Nominal efficiency of the fuel stack	55%
Response time of Fuel Cell voltage	1s
Voltage undershoot	2V

3.2. Supercapacitors

Supercapacitors are one of the recent advancements for power storage devices, especially in integrated devices. A capacitance (C_{sc}) is linked to an equivalent series resistance R_{sc} under this setup. The parameters of UC are shown in Table 2. The formula is used to determine the supercapacitor voltage (V_{sc}) as a result of the SC current (I_{sc}) [30].

$$V_{sc} = V_1 - R_{sc} \times I_{sc} = \frac{Q_{sc}}{S_{sc}} - R_{sc} \times I_{sc} \quad (3)$$

Utilizing supercapacitors as a storage system in such an electric vehicle implies the construction of such a stacking of cells, where N_s cells are interconnected in series and N_p cells are parallelly connected.

Table 2. Supercapacitor Specifications

<i>Supercapacitor Model (Input Parameters)</i>	<i>Specifications</i>
Surge Voltage	306V
Capacitor number in series	6
Capacitor counts in parallel	1
Rated voltage	290V
Rated Capacitance	14.5F
Operating Temperature	24°C

3.3. Battery

The battery is designed with a modest controlled power supply in series with such a fixed resistance [21]. Li-ion battery specifications are given in Table 3. Equation (1) defines the battery voltage Vbat.

$$V_{batt} = E - R_{bat} \cdot I_{bat} \quad (4)$$

Table 3. Li-ion Battery Specifications

<i>Battery Model (Input Parameters)</i>	<i>Specifications</i>
Minimal Voltage	48V
Determined capacity	40Ah
Esteemed Capacity	40Ah
Nominal Voltage capacity	35.15Ah
Response time of battery voltage	29s
Fully charged voltage	55.77V

3.4. Adaptive Network-Based Fuzzy Interface System (ANFIS)

Power management methods have emerged for an automated learning experience to assist industrial uses such as fuzzy approaches, which are more common in system control. The ANFIS is a vital approach, which integrates both the artificial neural network (ANN)-based learning ability and also a rule-based fuzzy logic control technique based on inference capacity to build a full set over all different types of neural networks in the feed-forward type using a supervisory learning functionality [31]. The ANFIS strategy accomplishes a hybrid training process based on appropriate information and parameters of input/output and connections.

Figure 3 illustrates that the ANFIS architecture comprises a single hidden layer. Layer 1 indicates the input node, layer 2 comprises the fuzzification nodes, layer 3 comprises the result nodes (hidden), layer 4 comprises the defuzzification nodes and layer 5 represents the output node [32]. Furthermore, a node can be updated, and it will be classified as dynamic and static. Dynamic nodes include layers 2 and 4, whereas the stable nodes are layer 1 and layer 3. The ANFIS control technique uses the SoC of a Li-ion battery with three membership functions (MFs) and also utilizes the vehicle energy load, which is represented by Pload, as inputs to anticipate the fuel cell’s output power [33]. The ANFIS outcome is the estimated proportional gain from the PEMFC level. The ANFIS measures and adjusts the norms rapidly while using proportional variables.

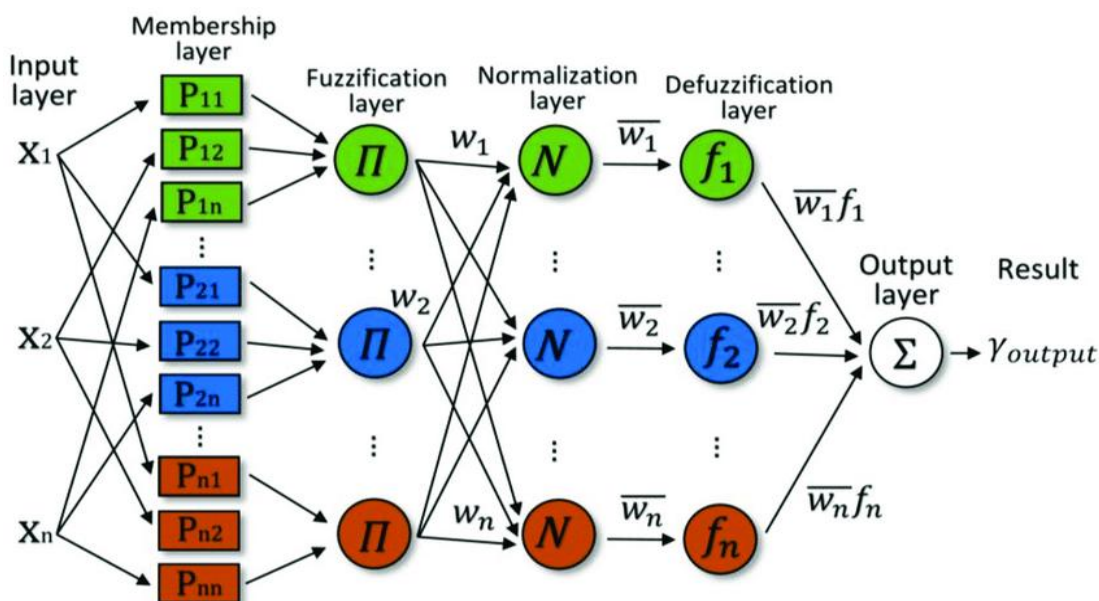

Figure 3. ANFIS five layer structure

IV. RESULTS AND DISCUSSION

In order to evaluate the goodness of the proposed ANFIS energy management strategy the performance of EV driving only with the battery, fuel cell and supercapacitor have been compared with the performance of EV driving. In Table 4 the main simulation parameters are reported.

Table 4. Comparison Performance [34]

Power Device's	Drive range (km)	Specific Energy Consumption (Wh/km)	Energy saving (%)
Fuel cell	150	93	+13
Supercapacitor	150	91	+15
Battery	150	90	+2.5

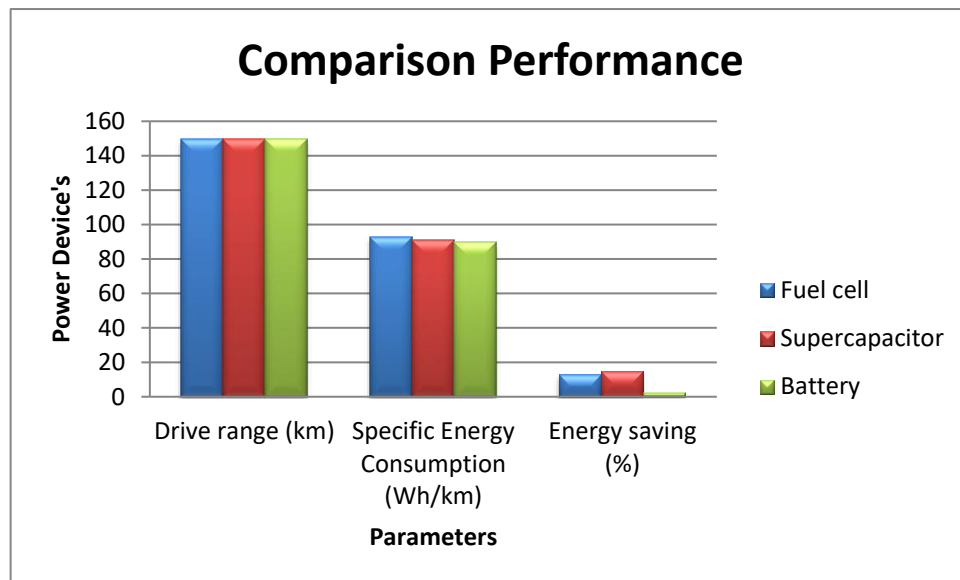

Figure 4. Comparison performance

Table 5. Characteristics of present and future battery cell technologies for EVs [35]

Parameter's	Cell voltage	Ah	Wgt.kg	EV W/kg	HEV W/kg
Batteries	2.8	30	87	140	521
Fuel	2.7	15	60	127	540
Super capacitor	3.4	20	24	5.5	250
PV	1.5	20	24	40	156

Table 6. The Simulation Results Comparison For Different Driving Cycles [36]

Driving Cycle	Proposed HEV FC/Bat (kW)	Proposed HEV FC/PV/Bat (kW)	Proposed HEV FC/Bat/PV/UC (kW)
UDDS	7.57	7.64	7.85
NEDC	5.28	5.33	5.54
JP	3.43	3.81	3.90

Also, in this paper, the proposed EMS for the online driving cycle has been compared with dynamic programming, which is the most effective offline global optimization method. The advantage of the proposed strategy over the dynamic programming method will ensure the priority and effectiveness of the proposed strategy. Moreover, PEMFC generated power in the dynamic programming method is not limited to specific operation points. The simulation results of the proposed strategy are compared with the results of the dynamic programming approach, which is the most effective offline global optimization method. The proposed EMS fuel consumption is approximately equal to DP method; for instance, the fuel consumption in proposed EMS is 7.64 MPG, while the fuel consumption in DP strategy is 7.65 MPG in UDDS driving cycle for the same FC/battery/UC structure. Also, battery power fluctuations are listed in Table 4. The results indicate that FC/battery/UC structure with proposed EMS has minimum power fluctuations compared with other strategies.

V. CONCLUSION

An ANFIS for power management in hybrid electric vehicles is proposed in this paper to conserve maximum fuel, with the main power source as a fuel cell (FC) and secondary sources as a battery bank (BB) and ultracapacitors (UC). The ECMS is a cost function-based optimization approach where the SoC of the battery is regulated by the penalty coefficients of battery power. The power of UC is overlooked in this optimization approach. The voltage profile of the DC bus is regulated by converters of the battery bank such that, once the UCs are drained, they are restored with the same power

from the battery bank. The load demand is balanced via a battery and FC over a load cycle. The ANFIS-based controller efficiently monitors the fluctuating energy demand but also continues to maintain a DC bus voltage profile with a limited error signal as well as a rapid trackability level compared to that of a conventional control system. Since continuous monitoring enhances the battery's lifespan, the performance of HEVs will be superior and more reliable. For all the control strategies, the value of the DC link is maintained at around (270 VDC). Energy management in hybrid vehicles must adopt a multi-scheme EMS since each approach is chosen as per key variables. For instance, depending on the actual lifespan of the input sources, EMS can indeed be employed to optimize the source lifespan or reduce the stress on FC/B/UC.

REFERENCES:

1. Zhang, F.; Wang, L.; Coskun, S.; Pang, H.; Cui, Y.; Xi, J. Energy management strategies for hybrid electric vehicles: Review, classification, comparison, and outlook. *Energies* 2020, 13, 3352.
2. Duhr, P.; Christodoulou, G.; Balerna, C.; Salazar, M.; Cerofolini, A.; Onder, C.H. Time-optimal gearshift and energy management strategies for a hybrid electric race car. *Appl. Energy* 2021, 282, 115980.
3. Guo, N.; Zhang, X.; Zou, Y.; Guo, L.; Du, G. Real-time predictive energy management of plug-in hybrid electric vehicles for coordination of fuel economy and battery degradation. *Energy* 2021, 214, 119070.
4. Li, Q.; Chen, W.; Liu, S.; You, Z.; Tao, S.; Li, Y. Power management strategy based on adaptive neuro-fuzzy inference system for fuel cell-battery hybrid vehicle. *J. Renew. Sustain. Energy* 2012, 4, 013106.
5. Allahvirdizadeh, Y.; Mohamadian, M.; HaghiFam, M.R.; Hamidi, A. Optimization of a fuzzy-based energy management strategy for a PV/WT/FC hybrid renewable system. *Int. J. Renew. Energy Res.* 2017, 7, 1686–1699.
6. Yavasoglu, H.A.; Tetik, Y.E.; Ozcan, H.G. Neural network-based energy management of multi-source (battery/UC/FC) powered electric vehicle. *Int. J. Energy Res.* 2020, 44, 12416–12429.
7. Montazeri-Gh, M.; Pourbafarani, Z. Near-optimal SOC trajectory for traffic-based adaptive PHEV control strategy. *IEEE Trans. Veh. Technol.* 2017, 66, 9753–9760.
8. Singh, K.V.; Bansal, H.O.; Singh, D. Development of an adaptive neuro—Fuzzy inference system—based equivalent consumption minimization strategy to improve fuel economy in hybrid electric vehicles. *IET Electr. Syst. Transp.* 2021, 11, 171–185.
9. Suhail, M.; Akhtar, I.; Kirmani, S.; Jameel, M. Development of progressive fuzzy logic and ANFIS control for energy management of plug-in hybrid electric vehicle. *IEEE Access* 2021, 9, 62219–62231.
10. Kamel, A.A.; Rezk, H.; Abdelkareem, M.A. Enhancing the operation of fuel cell-photovoltaic-battery-supercapacitor renewable system through a hybrid energy management strategy. *Int. J. Hydrogen Energy* 2021, 46, 6061–6075.
11. Song, Z.; Hofmann, H.; Li, J.; Hou, J.; Han, X.; Ouyang, M. Energy management strategies comparison for electric vehicles with a hybrid energy storage system. *Appl. Energy* 2014, 134, 321–331.
12. Gaber, M.; El-Banna, S.; El-Dabah, M.; Hamad, O. Designing and implementation of an intelligent energy management system for electric ship power system based on adaptive neuro-fuzzy inference system (ANFIS). *Adv. Sci. Technol. Eng. Syst. J.* 2021, 6, 195–203.
13. Tian, X.; He, R.; Xu, Y. Design of an energy management strategy for a parallel hybrid electric bus based on an IDP-ANFIS scheme. *IEEE Access* 2018, 6, 23806–23819.
14. Ding, N.; Prasad, K.; Lie, T.T. Design of a hybrid energy management system using designed rule-based control strategy and genetic algorithm for the series-parallel plug-in hybrid electric vehicle. *Int. J. Energy Res.* 2021, 45, 1627–1644.
15. Colvin, R. *Advances in Automotive Technologies*; Springer: Berlin/Heidelberg, Germany, 2019; Volume 84, ISBN 9789811559464.
16. Zhang, X.; Guo, L.; Guo, N.; Zou, Y.; Du, G. Bi-level energy management of plug-in hybrid electric vehicles for fuel economy and battery lifetime with intelligent state-of-charge reference. *J. Power Sources* 2021, 481, 228798.
17. Cai, C.H.; Du, D.; Liu, Z.Y. Battery state-of-charge (SOC) estimation using adaptive neuro-fuzzy inference system (ANFIS). *IEEE Int. Conf. Fuzzy Syst.* 2003, 2, 1068–1073.
18. Shaik, R.B.; Kannappan, E.V. Application of adaptive neuro-fuzzy inference rule-based controller in hybrid electric vehicles. *J. Electr. Eng. Technol.* 2020, 15, 1937–1945.
19. Li, P.; Jiao, X.; Li, Y. Adaptive real-time energy management control strategy based on fuzzy inference system for plug-in hybrid electric vehicles. *Control Eng. Pract.* 2021, 107, 104703.
20. Karaboga, D.; Kaya, E. Adaptive network-based fuzzy inference system (ANFIS) training approaches: A comprehensive survey. *Artif. Intell. Rev.* 2019, 52, 2263–2293.
21. Zhang, F.; Hu, X.; Langari, R.; Wang, L.; Cui, Y.; Pang, H. Adaptive energy management in automated hybrid electric vehicles with flexible torque request. *Energy* 2021, 214, 118873.
22. Zhang, L.; Ye, X.; Xia, X.; Barzegar, F. A real-time energy management and speed controller for an electric vehicle powered by a hybrid energy storage system. *IEEE Trans. Ind. Inform.* 2020, 16, 6272–6280.
23. Zhang, Q.; Li, G. A predictive energy management system for hybrid energy storage systems in electric vehicles. *Electr. Eng.* 2019, 101, 759–770.
24. Zhang, Q. Applied sciences strategy for hybrid electric vehicles based on driving cycle recognition. *Appl. Sci.* 2020, 10, 696.
25. Wiczorek, M.; Lewandowski, M. A mathematical representation of an energy management strategy for hybrid energy storage system in electric vehicle and real-time optimization using a genetic algorithm. *Appl. Energy* 2017, 192, 222–233.

26. Sarkar, J.; Bhattacharyya, S. Application of graphene and graphene-based materials in clean energy-related devices Minghui. *Int. J. Energy Res.* 2012, 33, 23–40.
27. Gomes, G.F.; da Cunha, S.S.; Ancelotti, A.C. A sunflower optimization (SFO) algorithm applied to damage identification on laminated composite plates. *Eng. Comput.* 2019, 35, 619–626.
28. Mirjalili, S.; Gandomi, A.H.; Mirjalili, S.Z.; Saremi, S.; Faris, H.; Mirjalili, S.M. Salp swarm algorithm: A bio-inspired optimizer for engineering design problems. *Adv. Eng. Softw.* 2017, 114, 163–191.
29. Mirjalili, S.; Mirjalili, S.M.; Hatamlou, A. Multi-verse optimizer: A nature-inspired algorithm for global optimization. *Neural Comput. Appl.* 2016, 27, 495–513.
30. Saremi, S.; Mirjalili, S.; Lewis, A. Grasshopper optimisation algorithm: Theory and application. *Adv. Eng. Softw.* 2017, 105, 30–47.
31. Mirjalili, S.; Mirjalili, S.M.; Lewis, A. Grey wolf optimizer. *Adv. Eng. Softw.* 2014, 69, 46–61.
32. Rezk, H.; Al-Oran, M.; Gomaa, M.R.; Tolba, M.A.; Fathy, A.; Abdelkareem, M.A.; Olabi, A.G.; El-Sayed, A.H.M. A novel statistical performance evaluation of most modern optimization-based global MPPT techniques for a partially shaded PV system. *Renew. Sustain. Energy Rev.* 2019, 115, 109372.
33. Abdalla, O.; Rezk, H.; Ahmed, E.M. Wind-driven optimization algorithm based global MPPT for PV system under non-uniform solar irradiance. *Sol. Energy* 2019, 180, 429–444.
34. Tolba, M.; Rezk, H.; Diab, A.A.Z.; Al-Dhaifallah, M. A novel robust methodology based salp swarm algorithm for allocation and capacity of renewable distributed generators on distribution grids. *Energies* 2018, 11, 2556.
35. Yadav, N.; Yadav, A.; Bansal, J.C.; Deep, K.; Kim, J.H. *Harmony Search and Nature Inspired Optimization Algorithms: Theory and Applications*, ICHSA 2018; Springer: Berlin/Heidelberg, Germany, 2019; Volume 741, ISBN 9789811307607.
36. Mirjalili, S. Particle swarm optimization. *Stud. Comput. Intell.* 2019, 780, 15–31.