

¹ Kaoutar Lahmadi² Ismail Boumhidi

Optimizing Control and Energy Management in a TS Fuzzy Wind System using LMI Approach



Abstract: - The focus of this research is to develop an optimal control and management strategy for wind energy systems. To achieve this goal, the study uses a combination of control design methods, including the Lyapunov function, sliding mode observer (SMO), and a PDC (Parallel Distributed Compensation) structure. These methods are employed to optimize the control of the wind energy system, ensuring that it operates at its maximum power output. To implement the control design methods, the wind turbine model is linearized using the Takagi-Sugeno (TS) fuzzy model. This allows the researchers to apply the linear matrix inequality (LMI) optimization algorithm to find a common solution that guarantees the asymptotic stability of the system. The objective of the proposed control design method is not only to extract the maximum power from the wind system but also to regulate the energy supplied to various loads and protect the battery against overcharging and deep charging. This is achieved through a global management strategy that is implemented in the state-flow. The simulation results of the proposed control and management strategy demonstrate its effectiveness in regulating the energy supplied by the wind system and protecting the battery. This research contributes to the development of more efficient and reliable wind energy systems, which are crucial in the shift towards sustainable and renewable energy sources.

Keywords: Wind generator system, Management energy system, Takagi Sugeno fuzzy model, sliding mode observer (SMO), linear matrix inequality (LMI).

I. INTRODUCTION

The use of wind energy as a renewable source of electricity has been growing in recent years due to its environmental benefits and its potential for meeting the increasing demand for energy. Wind turbines are able to generate electricity by harnessing the kinetic energy of wind and converting it into electrical energy.

However, the stochastic and uncontrollable nature of wind, such as changes in wind direction and speed, presents a challenge for wind turbine control. The wind turbine control system must be able to optimize the energy output while ensuring the safety and reliability of the wind turbine. This is particularly important in high wind conditions, which can cause significant damage to the wind turbine and surrounding infrastructure. One approach to addressing this challenge is the use of robust sliding mode observer-based controllers. These controllers are designed to estimate and compensate for the effects of wind disturbances on the wind turbine, allowing for improved energy production and system stability. By using advanced control techniques, wind turbines can be made more efficient and reliable, contributing to the growth and sustainability of wind energy as a clean and renewable energy source.

In this article, we present a novel design approach for observer-based control systems that uses sliding mode observers (SMOs) with discontinuous switched signals to feedback the error between the observer output and the system output, rather than a linear feedback mechanism. The effectiveness of this approach has been demonstrated through simulation studies on nonlinear systems [20]. Additionally, sufficient conditions have been derived for the stabilization of the robust fuzzy tracking controller and the robust fuzzy sliding mode observer, with respect to Lyapunov asymptotic stability [21]. To achieve this, a new methodology employing Linear Matrix Inequalities (LMIs) has been developed. The LMIs are used to determine the feedback gains of the fuzzy controller, SMO, and positive definite matrices P that satisfy a stability criterion established using the Lyapunov direct method [26]. This proposed design approach has practical significance because LMIs can be efficiently solved using convex optimization techniques.

In this work, TS fuzzy technique based on fuzzy modelling of the wind system is presented. The fuzzy Takagi-Sugeno TS model is a type of fuzzy model suitable for an approximation of a general class of nonlinear systems described by fuzzy if-then rules [22], it represents the input-output relationships of a system by expressing each conclusion by a linear system [11] [12]. This article also proposes an energy management strategy for wind system with lead-acid battery storage supplying loads. The specific objectives of energy management strategy are to deal

¹ Laboratory of innovation in management and engineering (LIMIE), Edvantis High education group, ISGA Fez, Morocco. Kaoutar.lahmadi@isga.ma

² Department of physics, Faculty of Sciences Dhar el Mahraz, University Sidi Mohammed Ben Abdellah Fez, Morocco. ismail.boumhidi@usmba.ac.ma

with the intermittent nature of wind power system and to extend the life of battery by preventing overcharging or deep/fast discharge [2].

The energy management system contains the maximum power extract from the optimal control of the fuzzy wind system to satisfy the energy demanded by the loads, when the wind system cannot produce enough energy during a certain period of time, battery storage is necessary to supply demand of loads, such management is also aimed at protecting the battery against overcharging by using a back-up battery and deep discharge using a diesel generator, so to be able to achieve this strategy, we used the state-flow approach in MATLAB /Simulink , this tool presents a graphical interface that allows good interaction with the models used the global simulation ,to show the functioning of the overall system including the management algorithm, we have applied different loads at different times, the objective is to show all the possible situations, also to show the good behaviour of the management algorithm in each situation.

The paper is organized as follows: In Section 2, we present a global system of the wind energy management, in section 3 we present wind conversion system control using TS fuzzy modelling, sliding mode observer and LMI approach. Due to the fluctuating nature of the wind energy source, battery is added in order to ensure continuous power-flow, [5], as well, we present in this section the model of the diesel generator, this section also presents an algorithm for wind energy management, while in Section 5, the simulation results obtained with MATLAB/ Simulink are presented and interpreted, in the final section 6 conclusions are drawn.

II. SYSTEM DESCRIPTION

Fig.1 shows the energy management of the wind system, it includes wind power, battery, loads, battery backup, Diesel Generator and the switches S1, S2, S3, S4 are used to control the interconnections between the energy source and the other units: battery, loads), these components are linked with an energy management system, the objective of this system is to develop management algorithm by using the state-flow approach which makes it possible to manage this type of constraints.

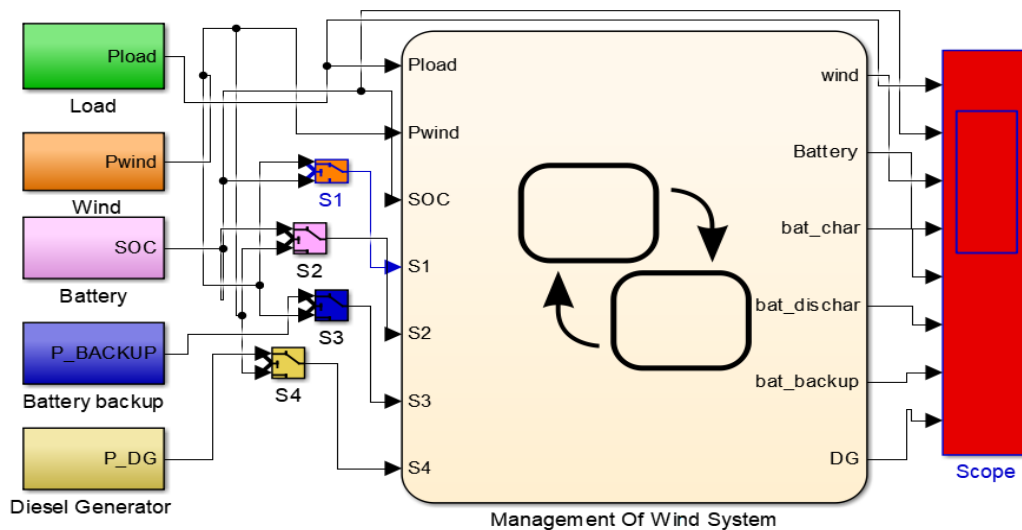

Fig. 1 The wind energy management model in Matlab / Simulink.

With:

P_DG: Power supplied by Diesel Generator.

P_BACKUP: Power supplied by battery backup.

State-flow variables:

- **System inputs**
 - Pload: Load power requested.
 - Pwind: Power supplied by the wind.
 - SOC: State of charge of a battery.
- **System outputs**
 - Wind: On/Of relay of wind.
 - Battery: On/Of relay of battery.
 - bat_char: On/Of relay of the charge.

bat_dischar: On/Of relay of the discharge.
 bat_backup: On/Of relay of battery backup.
 DG: On/Of relay of Diesel Generator.

III. MODELLING OF THE PROPOSED MODEL

A. Wind energy conversion system control using T-S fuzzy modelling and sliding mode: LMI Approach

The wind energy conversion system model used in this study is formed by a wind turbine coupled with a generator and mass train drive, this train can be modelled by equations (9) and (10) [17]. Wind speed varies with climate change, she is insufficient to ensure rotational speeds, so, it is important to insert a multiplier between the generator and the wind turbine, this multiplier is modelled by a gain G allows the machine to have a speed close to speed optimum [17], in order that it operates at the point of maximum power it is necessary to add a controller illustrated in Fig.2.

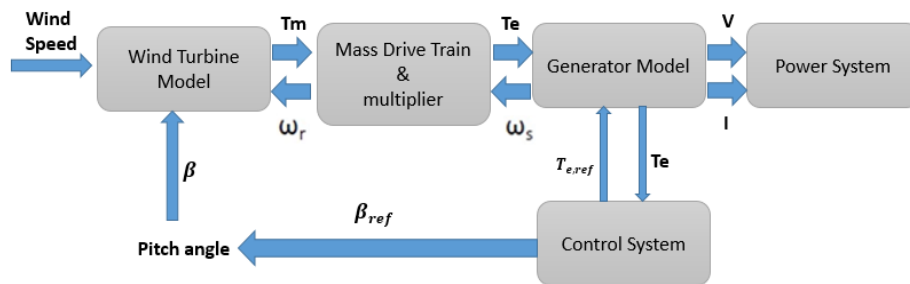

Fig. 2 Control strategy of wind energy conversion system.

The model of the system can be expressed by [4] [23]:

$$\begin{cases} \dot{x}(t) = A(q)x(t) + B_1 u(t) + B_2 V(t) \\ y(t) = Cx(t) \end{cases} \quad (1)$$

As a result, the global model system is given by [23]:

$$\begin{cases} \dot{x}(t) = \sum_{i=1}^4 h_i(q(t)) [A_i(t)x(t) + B_i u(t) + B_{2i} \delta(t)] \\ y(t) = \sum_{i=1}^4 h_i(q(t)) C_i x(t) \end{cases} \quad (2)$$

Sliding Mode Observer Based Controller with uncertainties parameter

The state equation and output equation can be modelled by:

$$\begin{cases} \dot{x}(t) = \sum_{i=1}^p h_i(q(t)) [(A_i + \Delta A_i)x(t) + (B_i + \Delta B_i)u(t) + B_{2i} \delta(t)] \\ y(t) = \sum_{i=1}^p h_i(q(t)) C_i x(t) \end{cases} \quad (3)$$

ΔA_i and ΔB_i are the uncertainties parameters.

To stabilize the fuzzy model TS, we apply the control law corresponding to a nonlinear state feedback. This command uses membership functions and constant gains.

The form of the command used in this approach is like that of a PDC except that it is dependent on the estimated state of the system:

$$u(t) = -\sum_{i=1}^p h_j(q(t)) K_j \hat{x}(t) \quad (4)$$

Consider the following sliding mode observer [7] :

$$\begin{cases} \dot{\hat{x}}(t) = \sum_{i=1}^p \sum_{j=1}^p h_i(q(t)) h_j(q(t)) \left(A_i \hat{x}(t) + B_i u(t) + L_j (y(t) - \hat{y}(t)) - \frac{R^{-1} C_i^T (C_i e_0(t))}{\|C_i e_0(t)\|} \delta \right) \\ \hat{y}(t) = \sum_{i=1}^p h_i(q(t)) (C_i \hat{x}(t)) \end{cases} \quad (5)$$

Where:

$\hat{x}(t) \in R^n$ is estimate of $x(t)$, $\hat{y}(t) \in R^p$ is estimate of $y(t)$ $L \in R^{n \times p}$ is the observer gain, R is symmetric positive definite matrix and δ is the bound of uncertainty. Let's define error of state estimation as:

$$e_0(t) = x(t) - \hat{x}(t) \tag{6}$$

Then, we can find the estimation error dynamics as follows:

$$\dot{e}_0(t) = \sum_{i=1}^p \sum_{j=1}^p h_i(q(t))h_j(q(t)) \left(\begin{array}{l} (A_i - L_j C_i) e_0(t) + (\Delta A_i - \Delta B_i K_j) x(t) + \frac{R^{-1} C_i^T (C_i e_0(t))}{\|C_i e_0(t)\|} \delta \\ + B_{2i} \hat{c}(t) \end{array} \right) \tag{7}$$

Substituting the controller in (13) with his expression in equation (14) and using (16) we obtained:

$$\dot{x}(t) = \sum_{i=1}^p \sum_{j=1}^p h_i(q(t))h_j(q(t)) \left((A_i - B_i K_j + \Delta A_i - \Delta B_i K_j) x(t) + (B_i K_j + \Delta B_i K_j) e_0(t) + B_{2i} \hat{c}(t) \right) \tag{8}$$

Theorem 1: Given the system described by (13). If there exist a symmetric and positive definite $P = P^T > 0$ some matrices X_j, W_j and a positive scalar, ζ_1, ζ_2 and ζ_3, ζ_4 such that the condition (19) hold for $1 \leq i < j \leq p$.

$$\begin{bmatrix} \Psi_{11} & B_i X_j & D_i Z & D_i Z & X_j^T N_{2i}^T & 0 & X_j^T N_{2i}^T & 0 & B_{2i} Z \\ * & \Psi_{22} & 0 & 0 & 0 & R D_i & 0 & R D_i & R B_{2i} \\ * & * & \zeta_1^{-1} I & 0 & 0 & 0 & 0 & 0 & 0 \\ * & * & * & \zeta_2^{-1} I & 0 & 0 & 0 & 0 & 0 \\ * & * & * & * & \zeta_2 I & 0 & 0 & 0 & 0 \\ * & * & * & * & * & \zeta_3^{-1} I & 0 & 0 & 0 \\ * & * & * & * & * & * & \zeta_4 I & 0 & 0 \\ * & * & * & * & * & * & * & \zeta_4^{-1} I & 0 \\ * & * & * & * & * & * & * & * & I \end{bmatrix} < 0 \tag{9}$$

B. Model of Battery

A dynamic battery presented in MATLAB /Simulink, the description of this generic battery model is presented in [24] we used the lead-acid battery model, which is represented by the equations in [24], the mode's parameters are extracted from the discharge characteristics, and the charge's parameters are considered the same.

C. Model of Diesel Generator

It is necessary in installations with autonomous renewable energy sources like wind system use storage or add one or more diesel generators.

The basic components of a diesel generator system are a diesel engine and a synchronous generator. To generate a constant generator frequency output, the diesel engine transfers the power required by the generator while maintaining the rated speed (ω). Power will be generated by a synchronous generator. The generator output is kept at its voltage rating by the excitation system. The diesel engine's operation is defined by the transfer function of the control system (28), and the transfer function of the actuator (29) [15], [16].

$$H_c = K \cdot \frac{T_3 s + 1}{T_1 T_2 s^2 + T_1 s + 1} \tag{10}$$

$$H_a = \frac{T_4 s + 1}{(1 + T_5 s) \cdot (1 + T_6 s) \cdot s} \tag{11}$$

Where H_c is transfer function of control system for governor and H_a is transfer function for the actuator. T_1, T_2 and T_3 are the time constants of regulator. T_4, T_5 and T_6 are the time constants of actuator K is regulator gain, Fig

4 shows the power of Diesel generator that involves Diesel engine, the governor, and the synchronous machine with excitation system in MATLAB /Simulink.

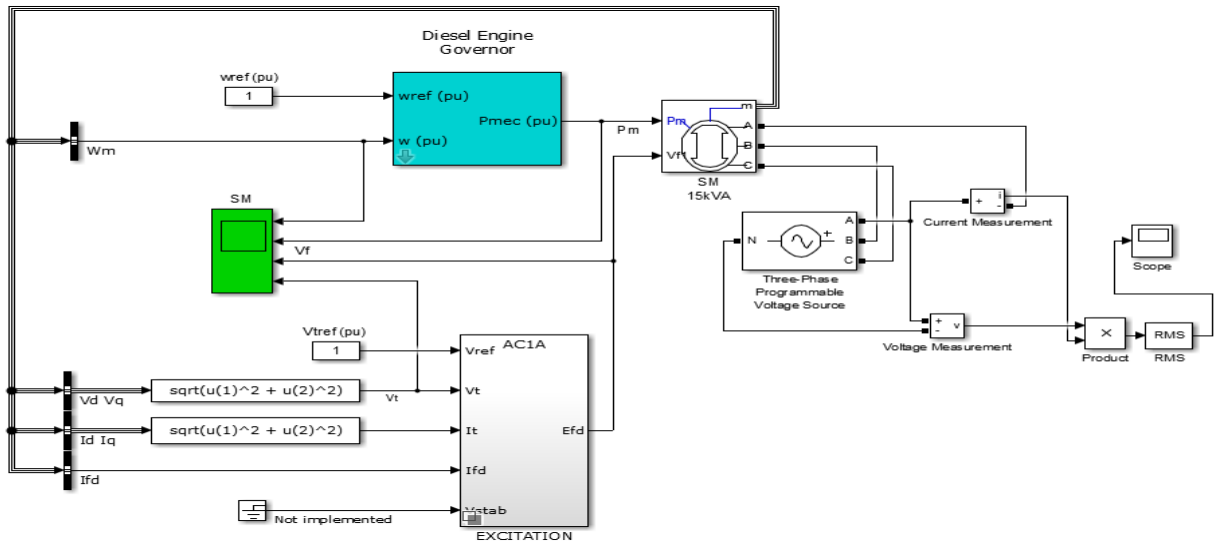

Fig.3. Model of Diesel Generator.

D. Energy management algorithm

The algorithm in Fig 5 can be used to describe the energy management system that we implemented in state-flow tool, which deals with the different possible situations that we are called to be confronted with. The proposed wind energy management algorithm can control the wind energy source and storage management by protecting the battery against overcharging and deep discharges.

According to this algorithm considering the state of charge of the battery, the power of the wind and that of the load can be affected by three input variables:

- Pwind:** wind power.
- Pload:** the requested power.
- SOC:** State of charge, SOC min = 20% (deep charging)
- SOC max = 80%** (overcharging).

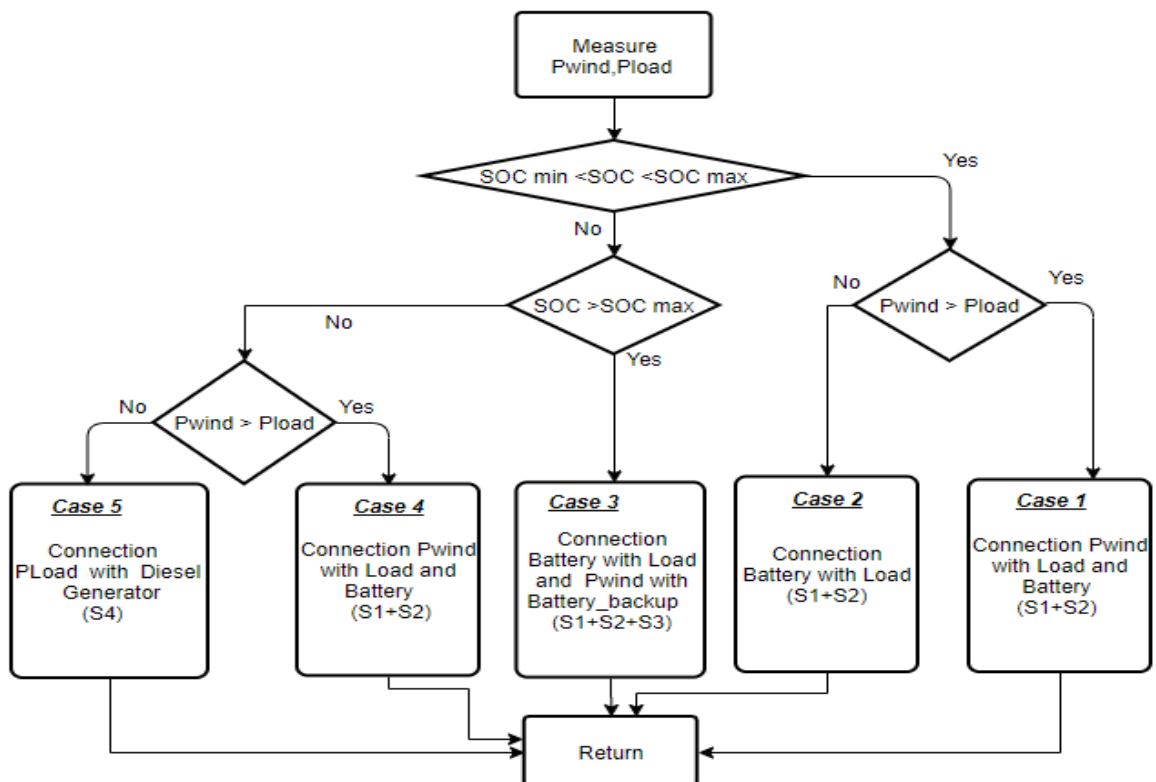

Fig.4. Management energy algorithm of the wind system.

There are five possibilities:

Case1:

The state of charge is between 20% and 80% and the power provided by the wind source supply exceeds the power demanded by the load, therefore the wind generates enough energy to supply the load and charge the battery.

Case 2:

The state of charge is between 20% and 80%, and the power provided by the wind source is less than that requested by the load, so the energy available by the wind is insufficient to supply the load. As a result, the battery is used to supplement the energy required by the load.

Case3:

In order to avoid battery overcharging as soon as the state of charge reaches 80%, the power supplied by the wind will be connected to a backup battery and the charge will be connected to the battery.

Case 4:

In this case the storage is empty SOC<20% (battery discharging), and the power supplied by the wind source is greater than that requested by the load, therefore the wind generates enough energy to supply the load and charge the battery.

Case 5:

The storage is empty SOC < 20% (battery discharging) and the power supplied by the wind source is less than that requested by the load so, Since the energy available from the wind is insufficient to power the load and the battery, the load and battery will be supplied by a diesel generator.

IV. SIMULATIONS RESULTS

The simulation results of the wind system control method and energy system management are presented in this section. Table 2 shows the nominal values of the function parameters.

Solving LMI stated in Theorem1, we obtained the results in terms of gains, it is clear that the proposed approach gives better results.

$$k_1 = 1.0e + 04^*$$

$$\begin{bmatrix} 0.0000 & 0.0000 & -0.0000 & -0.0000 \\ 5.8638 & 0.0112 & -0.0112 & 0.0015 \end{bmatrix}$$

$$k_2 = 1.0e + 04^*$$

$$\begin{bmatrix} 0.0000 & 0.0000 & -0.0000 & -0.0000 \\ 5.8638 & 0.0112 & -0.0112 & 0.0015 \end{bmatrix}$$

$$k_3 = 1.0e + 04^*$$

$$\begin{bmatrix} 0.0000 & 0.0000 & -0.0000 & -0.0000 \\ 5.8638 & 0.0112 & -0.0112 & 0.0015 \end{bmatrix}$$

$$k_4 = 1.0e + 04^*$$

$$\begin{bmatrix} 0.0000 & 0.0000 & -0.0000 & -0.0000 \\ 5.8638 & 0.0112 & -0.0112 & 0.0015 \end{bmatrix}$$

$$L_1 = \begin{bmatrix} 0.0120 \\ 0.0008 \\ 0.1804 \\ 0.0000 \end{bmatrix} L_2 = \begin{bmatrix} 0.0120 \\ 0.0008 \\ 0.1804 \\ 0.0000 \end{bmatrix}$$

$$L_3 = \begin{bmatrix} 0.0120 \\ 0.0008 \\ 0.1804 \\ 0.0000 \end{bmatrix} L_4 = \begin{bmatrix} 0.0120 \\ 0.0008 \\ 0.1804 \\ 0.0000 \end{bmatrix}$$

V. CONCLUSION

This article presents a method for controlling a wind power system using TS fuzzy conversion to extract maximum power. In addition, a state flow approach is proposed to manage the entire system, which includes the wind system, battery, loads, diesel generator, and backup battery. The purpose of this approach is to ensure the effective management of the energy produced by the wind power system, regardless of the operating conditions.

The proposed control method utilizes a sliding mode observer to estimate the state variables of the wind system. The observer uses the measured output data from the wind turbine and the battery to estimate the state variables. The observer is designed to be robust to uncertainties in the wind system and to maintain accurate estimates of the state variables, even in the presence of noise.

To evaluate the performance of the proposed control method, simulations were conducted using the Matlab LMI toolbox. The results of the simulations demonstrate that the performance of stability and robustness are guaranteed, as well as the efficiency of the sliding mode observer. The simulation results also demonstrate that the proposed strategy effectively manages the elements of the wind system based on the operating mode (wind energy surplus or deficit) and the state of each component (battery charge/discharge).

Overall, the proposed control method and state flow approach represent a promising solution for managing wind power systems. By utilizing TS fuzzy conversion and a sliding mode observer, the control method can effectively extract maximum power from the wind turbine and ensure stable operation of the system. The state flow approach provides a comprehensive framework for managing the energy produced by the wind power system, and the simulation results demonstrate its effectiveness.

REFERENCES

- [1] A. Gaillard "Système éolien basé sur une MADA : contribution à l'étude de la qualité de l'énergie électrique et de la continuité de service", Thèse de doctorat, Université Henri Poincaré, Nancy-I ,2010.
- [2] R. Bhatti and Z. Salam, "A rule-based energy management scheme for uninterrupted electric vehicles charging at constant price using photovoltaic-grid system," *Renewable Energy*, vol. 125, pp. 384-400, 2018/09/01/ 2018.
- [3] R. Babouria, D. Aouzlagb ,K. Ghedamsi, "Integration of Doubly Fed Induction Generator Entirely Interfaced With Network in a Wind_Energy Conversion System", *Energy Procedia* 36 (2013) 169 – 178.
- [4] F.D. Bianchi, R.J. Mantz, "Gain scheduling control of variable speed wind energy conversion systems using quasi-LPV models," *Control Engineering Practice*, Vol. 13, No.3, pp. 247-255,2005.
- [5] M. Oudghiri, M. Chadli and A. El Hajjaji, "Commande multimodèles tolérante aux défauts : Application au contrôle de la dynamique d'un véhicule automobile". Thèse de Doctorat, de l'université de Picardie jules verne, Octobre 2008.
- [6] Chang-Hua Lien, "Robust Observer-Based Control of Systems with State Perturbations via LMI Approach," *IEEE Transactions on Automatic Control*, vol. 49, no. 8, August 2004.
- [7] L. Walcott and S. H. Zak, "Combined Observer-Controller Synthesis for Uncertain Dynamical Systems with Applications," *IEEE Transactions on Systems, Man, and Cybernetics*, vol. 18, no. 1, pp. 88- 104, 1988.
- [8] S. K. Spurgeon, "Sliding Mode Observer: A survey," *International Journal of Systems Science*, vol. 39, no. 8, pp.751–764, 2008.
- [9] S.Tong, H.-H. Li," Observer-based robust fuzzy control of nonlinear systems with parametric uncertainties," *Fuzzy Sets and Systems*, vol. 131, pp. 165 -184, 2002.
- [10] Y. M. Cho and R. Rajamani, "A Systematic Approach to Adaptive Observer Synthesis for Nonlinear Systems," *IEEE Transactions on Automatic Control*, vol. 42, no. 4, April 1997.
- [11] T. Takagi, M. Sugeno, "Fuzzy identification of systems and its application to modeling and control," *IEEE Trans. System Man Cybernet.* SMC-15, 1985, pp. 110-132. doi: 10.1109/TSMC.1985.6313399
- [12] K. Tanaka, K. O. Wang , "Fuzzy Control Systems Design and Analysis: A linear Matrix Inequality Approach," John Wiley & Sons, Inc., 2001.
- [13] Pukdeboon, A. S. I. Zinober, and M. W. L. Thein, "Quasi-continuous higher order sliding-mode controllers for spacecraft-attitude tracking maneuvers," *IEEE Trans. Ind. Electron.*, vol. 57, no. 4, pp. 1436–1444, Apr. 2010
- [14]] L. L. Show, J. C. Juang, and Y. W. Jan, "An LMI-based nonlinear attitude control approach," *IEEE Trans. Control Syst. Technol.*, vol. 11, no. 1, pp. 73–83, Jan. 2003
- [15] Grama and D. Petreus, "Simulink model for a bio-diesel electrical power generator used into a farm," vol. 56, 2015
- [16] M Zaky Zaim Muhtadi, Soedibyo, Mochamad Ashari," Penetration of Photovoltaic – Synchronous Diesel Generator Systems without Storage for Isolated Area", Proc. ICOMITEE 2019, October 16th-17th 2019, Jember, Indonesia.
- [17] K.Elkhatab, A. Aitouche, D. ABBES, "Robust fuzzy scheduler fault tolerant control of wind energy systems subject to sensor and actuator faults", *International Journal of Electrical Power and Energy Systems*, Volume 55, February 2014, pp. 402–419
- [18] O. Lodin, N.khajuria, S.Vishwakarma, G.Manzoor," Modeling and Simulation of Wind Solar Hybrid System using Matlab/Simulink", *International Journal of Innovative Technology and Exploring Engineering (IJITEE)* ISSN: 2278-3075, Volume-8, Issue-9S, July 2019

- [19] Bouharchouche, et al., "Control and energy management of a grid connected hybrid energy system PV-wind with battery energy storage for residential applications," in 2013 Eighth International Conference and Exhibition on Ecological Vehicles and Renewable Energies (EVER), 2013, pp. 1-11.
- [20] J. Koshkouei and A. S. I. Zinober, "Sliding mode state observation for non-linear systems," *International Journal of Control*, vol. 77, no. 2, pp. 118-127, 2004.
- [21] F.Khaber, A.Hamzaoui, K. Zehar "State Feedback Controller Design via Takagi-Sugeno fuzzy Model : A Linear Matrix Inequalities Approach"
- [22] Y. Berrada, A. El Bakri, and I. Boumhidi, "Feedback T-S fuzzy controller in finite frequency for wind energy conversion systems based on neural network", In: Proc of Intelligent Systems and Computer Vision, pp. 1-6, 2017.
- [23] K.Lahmadi, S. Aboulem, I. Boumhidi , "LMI Conditions to Design a Robust Fuzzy Controller for a Wind Generator," IEEE International Conference on Systems and Control ,2016
- [24] K. A. Naik, C. P. Gupta, and E. Fernandez, "Design and implementation of interval type-2 fuzzy logic-PI based adaptive controller for DFIG based wind energy system", *International Journal of Electrical Power & Energy Systems*, Vol.115, 2020.
- [25] MathWorks Inc. SimPowerSystems Toolbox Users' Manual, version 5.2; MathWorks Inc.: Natick, MA, USA, 2010.
- [26] M. Chadli and A. El Hajjaji , "Wind energy conversion systems control using T-S fuzzy modelling", 18th Mediterranean Conference on Control & Automation Congress, Marrakech, Morocco June 23-25, 2010.