

**Bolla
Madhusudana
Reddy^{1*},
Pasala Gopi¹,
Y.V.Siva Reddy²**

J. Electrical Systems 18-1 (2022): 65-81



**Journal of
Electrical
Systems**

Regular paper

Performance improvement of closed loop optimal cascaded high level multilevel inverter fed induction motor drive using ANFIS with low THD and effective speed-torque control

Multilevel inverters (MLIs) are mainly attracted by many researchers due to the cause of minimum harmonic distortion and production of good quality medium and high power output than that of conventional two level inverters. This paper presents 63 level optimal structured single phase MLI by means of fewer switches and sinusoidal pulse width modulation (SPWM) technique for controlling switching actions according requirements. Later it implemented as three phase optimal cascaded 63 level multilevel inverter with same SPWM technique controlling technique. Closed loop optimal cascaded high level multilevel inverter feeding induction motor drive with Fuzzy Logic Controller (FLC) has been designed. To obtain better performance with same drive, replace FLC with Adaptive Neuro Fuzzy Inference System (ANFIS) controller by verifying voltage, current, distortion and speed- torque under no load and ON load conditions. The proposed drive of validity has been proved with MATLAB/SIMULINK.

Keywords: Multilevel inverter, Induction motor, FLC, ANFIS, THD, Speed, Torque

1. Introduction

The multilevel inverters (MLIs) are consisting of power semiconductor switches arranged in such a manner with number of DC sources used for generating alternating wave form with different steps of voltage levels. When compared to classical two level inverters these MLIs [1, 2, 3] have tremendous features such as low switching losses, low electromagnetic interference, and minimum distortion, reduced dv/dt stress on load and quality output waveform. If number of levels are improved in output waveform that leads to decrease total harmonic distortion.

Generally classical MLIs are categorized in three types (i) Neutral point or diode clamped MLIs [4, 5] (ii) Flying or fixed capacitor MLIs [6] (iii) Cascaded multilevel inverters [7]. With above classical MLIs some other topologies are switched capacitor multilevel inverters [8], hybrid type MLIs with combination of diode clamped and flying capacitor [9]. Inverse voltage MLIs [10] and modular MLIs¹¹ presented. The performance investigation for four Switch three phase inverter with PI and FLC was implemented [12]. A control technique was implemented with new neural network applicable to induction motor [13]. An induction motor had been controlled by using direct torque control method with sophisticated lookup tables based on neural networks [14]. Common mode voltage can be minimized using novel space vector PWM with direct torque control feeding induction motor [15]. Comparison of closed loop optimal high level novel multilevel inverter fed induction motor drive using PI controller and fuzzy logic controller described [16]. Initially in industry applications three phase inverter with six switches were used which were not suitable for medium and high voltage or power requirements due to high switching losses, controlling technique complexity and low quality output. To avoid such problems classical multilevel inverters were designed and implemented. Problem in classical MLIs were more

*Corresponding author; Dr.Bolla Madhusudana Reddy , madhusudhanareddy.bolla@gmail.com

¹ Department of EEE, Annamacharya Institute of Technology & Sciences, Rajampet, AP, India

² Department of EEE, G.Pulla Reddy Engineering College, Kurnool, AP, India

switching devices, DC sources with high standing voltages and distortion. Most of the industrial requirements three phase induction motors used due to their simple construction and ruggedness.

Still to improve performance of AC motor drives an optimal structured 63 level MLI is proposed with minimum required count of switches and DC sources through sinusoidal pulse width modulation control technique for proper operation switches. The proposed MLI produces very low switching losses, low off state voltage drops and minimum Total Harmonic Distortion (THD) due to the cause of almost sinusoidal output wave form by increasing number of levels. The proposed MLI control of induction motor drive through FLC is compared with proposed MLI feeding induction motor drive with ANFIS controller for achieving better speed torque performance

2. Notation

The notation used throughout the paper is stated below.

s = number of dc voltage sources for each sub unit; u =Total number of Sub units

N_{SWITCH} = Number of switches in proposed MLI; N_{DRIVER} = Number of gate drivers proposed MLI

N_{IGBT} =Number of IGBTs proposed MLI; N_{SOURCE} = Number of DC voltage sources proposed MLI

K = Sub multilevel inverter number ; N_{LEVEL} = Number of output voltage level in proposed novel multilevel inverter

J -Moment of inertia; W_r -Rotor speed (rad/sec) ; B - friction coefficient; T_L -Load torque; S - Slip of induction motor

f -Frequency of supply to stator of IM ; P -Poles number of magnet

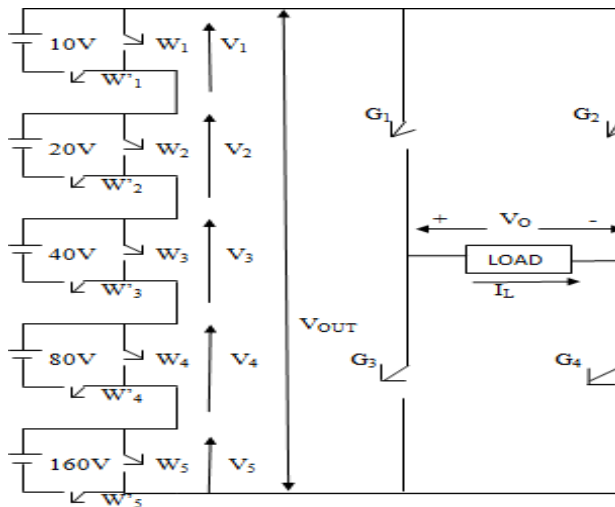

Figure 1. Single phase proposed optimal cascaded 63 level MLI

3. Design of proposed optimal cascaded high level multilevel inverter

The proposed optimal cascaded 63 level MLI is shown in figure 1 which is designed with series connection of 'u' number of sub units to achieve more steps of voltage levels in output waveform. Each sub unit contains one DC voltage source and two switches. The number of output levels in voltage wave form decided based on quantity of DC sources applied in every one sub division of proposed MLI. If all

's' number of DC sources values are same then low levels are obtained in output but with different values of DC sources with ratio of 1:2:4:8:16 applied to respective sub units, more number of levels are achieved in output.

$$N_{SWITCH} = 2u + 4, \text{ when } s = 1$$

$$= m \quad (n + 2), \text{ when } n \geq 2 \tag{1}$$

$$N_{DRIVER} = N_{SWITCH} \tag{2}$$

$$N_{IGBT} = 2us + 4 \tag{3}$$

$$N_{SOURCE} = u * s \tag{4}$$

$$V_{dc,1} = V_{dc,2} = \dots = V_{dc,u} \tag{5}$$

Output Voltage Level $N_{Level} = 2us + 1$; if DC sources equal $\tag{6}$

$$V_{DC,J} = (s + 1)^{(k+1)} V_{DC,1} ; k = 1, 2, \dots, u \tag{7}$$

Output Voltage Level $N_{Level} = 2^{(u+1)} + 1$; if DC sources unequal $\tag{8}$

Where V_{DC} , N_{SWITCH} , N_{DRIVER} , N_{IGBT} , N_{SOURCE} , N_{LEVEL} are the dc voltages of K^{TH} sub unit, number of switches, number of switches' drivers, number of IGBTs and total number of DC sources respectively for proposed MLI. Series connected sub units of proposed MLI produces only zero and positive levels of output .An H bridge is connected across series combination of sub units to obtain negative levels in addition with positive levels and zero level. The positive levels of output voltages are obtained during the ON condition of 'G1' and 'G4' devices in the H-Bridge and negative levels of output voltages are achieved for ON position of 'G2' and 'G3' in the H- Bridge.

Table 1. ON state switching patterns for 63 level proposed optimal MLI

V (pu)	ON Switching patterns	Level N	V (pu)	ON Switching patterns	Level N
+31	W'1 W'2 W'3 W'4 W'5 G1 G4	1	-31	W'1 W'2 W'3 W'4 W'5 G2 G3	33
+30	W1 W'2 W'3 W'4 W'5 G1 G4	2	-30	W1 W'2 W'3 W'4 W'5 G2 G3	34
+29	W'1 W2 W'3 W'4 W'5 G1 G4	3	-29	W'1 W2 W'3 W'4 W'5 G2 G3	35
+28	W1 W2 W'3 W'4 W'5 G1 G4	4	-28	W1 W2 W'3 W'4 W'5 G2 G3	36
+27	W'1 W'2 W3 W'4 W'5 G1 G4	5	-27	W'1 W'2 W3 W'4 W'5 G2 G3	37
+26	W1 W'2 W3 W'4 W'5 G1 G4	6	-26	W1 W'2 W3 W'4 W'5 G2 G3	38
+25	W'1 W2 W3 W'4 W'5 G1 G4	7	-25	W'1 W2 W3 W'4 W'5 G2 G3	39
+24	W1 W2 W3 W'4 W'5 G1 G4	8	-24	W1 W2 W3 W'4 W'5 G2 G3	40
+23	W'1 W'2 W'3 W4 W'5 G1 G4	9	-23	W'1 W'2 W'3 W4 W'5 G2 G3	41
+22	W1 W'2 W'3 W4 W'5 G1 G4	10	-22	W1 W'2 W'3 W4 W'5 G2 G3	42
+21	W'1 W2 W'3 W4 W'5 G1 G4	11	-21	W'1 W2 W'3 W4 W'5 G2 G3	43
+20	W1 W2 W'3 W4 W'5 G1 G4	12	-20	W1 W2 W'3 W4 W'5 G2 G3	44
+19	W'1 W'2 W3 W4 W'5 G1 G4	13	-19	W'1 W'2 W3 W4 W'5 G2 G3	45
+18	W1 W'2 W3 W4 W'5 G1 G4	14	-18	W1 W'2 W3 W4 W'5 G2 G3	46
+17	W'1 W2 W3 W4 W'5 G1 G4	15	-17	W'1 W2 W3 W4 W'5 G2 G3	47
+16	W1 W2 W3 W4 W'5 G1 G4	16	-16	W1 W2 W3 W4 W'5 G2 G3	48

+15	W'1 W'2 W'3 W'4 W5 G1 G4	17	-15	W'1 W'2 W'3 W'4 W5 G2 G3	49
+14	W1 W2 W3 W'4 W5 G1 G4	18	-14	W1 W2 W3 W'4 W5 G2 G3	50
+13	W'1 W2 W'3 W'4 W5 G1 G4	19	-13	W'1 W2 W'3 W'4 W5 G2 G3	51
+12	W1 W2 W3 W'4 W5 G1 G4	20	-12	W1 W2 W3 W'4 W5 G2 G3	52
+11	W'1 W'2 W3 W'4 W5 G1 G4	21	-11	W'1 W'2 W3 W'4 W5 G2 G3	53
+10	W1 W'2 W3 W'4 W5 G1 G4	22	-10	W1 W'2 W3 W'4 W5 G2 G3	54
+9	W'1 W2 W3 W'4 W5 G G4	23	-9	W'1 W2 W3 W'4 W5 G2 G3	55
+8	W1 W2 W3 W'4 W5 G1 G4	24	-8	W1 W2 W3 W'4 W5 G2 G3	56
+7	W'1 W'2 W'3 W4 W5 G1 G4	25	-7	W'1 W'2 W'3 W4 W5 G1 G4	57
+6	W1 W'2 W'3 W4 W5 G1 G4	26	-6	W1 W'2 W'3 W4 W5 G1 G4	58
+5	W'1 W2 W'3 W4 W5 G1 G4	27	-5	W'1 W2 W'3 W4 W5 G2 G3	59
+4	W1 W2 W'3 W4 W5 G1 G4	28	-4	W1 W2 W'3 W4 W5 G2 G3	60
+3	W'1 W'2 W3 W4 W5 G1 G4	29	-3	W'1 W'2 W3 W4 W5 G2 G3	61
+2	W1 W'2 W3 W4 W5 G1 G4	30	-2	W1 W'2 W3 W4 W5 G2 G3	62
+1	W'1 W2 W3 W4 W5 G1 G4	31	-1	W'1 W2 W3 W4 W5 G2 G3	63
0	W1 W2 W3 W4 W5	32			

Table 1 shows the corresponding switches should be ON for producing various output voltage levels of proposed optimal 63 level MLI shown in figure 1. To get output level as 1 or voltage P.U as +31 the following switches W'_1 W'_2 W'_3 W'_4 W'_5 G_1 G_4 should be in ON condition. Suppose to achieve level 33 or P.U voltage is -31 switches $w'1$ W'_2 W'_3 W'_4 W'_5 G_2 G_3 need to be conducting state. W_1 W_2 W_3 W_4 W_5 switching devices required to turn ON for zero P.U voltage or 32 level output. In order to get 63 level or -1 P.U voltage the following switches W'_1 W_2 W_3 W_4 W_5 G_2 G_3 should be ON. Similarly based on level number or PU unit voltage above table 2 said respective switches are in ON state.

4. Design of proposed induction motor drive

The proposed MLI is extended as three phase 63 level optimal MLI is with star connection of three individual single phase 63 optimal MLIs. Hence the designed three phase optimal MLI is feeding with three phase induction motor with different controllers for improving drive performance.

Three phase induction motor torque equation

$$T_e = J d\omega_t / dt + B\omega_t + T_L \quad (9)$$

J-Moment of inertia; ω_t -Rotor speed (rad/sec), B-friction coefficient, T_L -Load torque

Induction motor rotor speed equation

$$\omega_t = \omega_s (1-s) \quad (10)$$

Synchronous speed (rad /sec)

$$\omega_s = 2\pi N_s / 60 \quad (11)$$

Synchronous speed (rev/min)

$$N_s = 120f / P \quad (12)$$

Slip of induction motor

$$S = (\omega_s - \omega_r) / \omega_s \tag{13}$$

‘S’ means Slip of induction motor, ‘f’ is Frequency of supply to stator of IM, ‘P’ means poles number of magnets.

4.1 Closed loop control of induction motor drive through fuzzy logic controller

The operation of FLC shown in figure 2 depends on linguistic rules IF, AND & THEN operators. The importance of FLC is make the induction motor actual current, voltage, speed and torque equals to given reference values of same .There are two inputs given to FLC one is error in voltage ‘ΔV’ and second is change in error voltage ‘ΔE’ and with five membership functions such as NH is Negative High, NL is Negative low, ZE is Zero Equal, PL is Positive low, PH is Positive High. By using above said five membership functions, 25 rules are made in FLC for reducing error between actual and reference values as shown table 2 for improving presentation of projected optimal MLI fed induction motor drive. The 63 level MLI feeding induction drive controlled by FLC block diagram is as shown in figure 4 by replacing ANFIS with FLC. The input to the FLC is the difference in

voltage between reference value and actual value obtained from MLI. The function of FLC controller is to decrease the steady state and transient error in voltage and the same as input to the induction motor for improving drive performance.

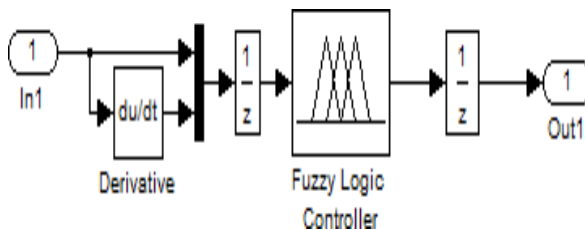

Figure 2. Fuzzy logic controller implementation in drive

Table 2. Rules for Fuzzy Logic Controller

S.No	Rule
1	IF (ΔV is NH) AND (ΔE is NH) THEN (ERROR is ZE)
2	IF (ΔV is NH) AND (ΔE is NL) THEN (ERROR is NL)
3	IF (ΔV is NH) AND (ΔE is ZE) THEN (ERROR is NH)
4	IF (ΔV is NH) AND (ΔE is PL) THEN (ERROR is NH)
5	IF (ΔV is NH) AND (ΔE is PH) THEN (ERROR is NH)
6	IF (ΔV is NL) AND (ΔE is NH) THEN (ERROR is PL)
7	IF (ΔV is NL) AND (ΔE is NL) THEN (ERROR is ZE)
8	IF (ΔV is NL) AND (ΔE is ZE) THEN (ERROR is NL)
9	IF (ΔV is NL) AND (ΔE is PL) THEN (ERROR is NH)
10	IF (ΔV is NL) AND (ΔE is PH) THEN (ERROR is NH)
11	IF (ΔV is ZE) AND (ΔE is NH) THEN (ERROR is PH)

12	IF (ΔV is ZE) AND (ΔE is NL) THEN (ERROR is PL)
13	IF (ΔV is ZE) AND (ΔE is ZE) THEN (ERROR is ZE)
14	IF (ΔV is ZE) AND (ΔE is PL) THEN (ERROR is NL)
15	IF (ΔV is ZE) AND (ΔE is PH) THEN (ERROR is NH)
16	IF (ΔV is PL) AND (ΔE is NH) THEN (ERROR is PH)
17	IF (ΔV is PL) AND (ΔE is NL) THEN (ERROR is PH)
18	IF (ΔV is PL) AND (ΔE is ZE) THEN (ERROR is PL)
19	IF (ΔV is PL) AND (ΔE is PL) THEN (ERROR is ZE)
20	IF (ΔV is PL) AND (ΔE is PH) THEN (ERROR is NL)
21	IF (ΔV is PH) AND (ΔE is NH) THEN (ERROR is PH)
22	IF (ΔV is PH) AND (ΔE is NL) THEN (ERROR is PH)
23	IF (ΔV is PH) AND (ΔE is ZE) THEN (ERROR is PH)
24	IF (ΔV is PH) AND (ΔE is PL) THEN (ERROR is PL)
25	IF (ΔV is PH) AND (ΔE is PH) THEN (ERROR is ZE)

In the above table 2 ' ΔV ' means voltage error as input 1; ' ΔE ' means change in voltage error as input 2 and 'ERROR' means output voltage error.

4.2 Closed loop control of induction motor drive with Adaptive Neuro Fuzzy Inference System controller

In figure 4, proposed novel three phase 63 level MLI is connected to three phase induction motor with ANFIS in closed loop control system. In proposed drive the three phase inverter is implemented with three single phase 63 level MLIs. When compared to closed loop drive with fuzzy logic controller, the proposed closed loop drive with ANFIS controller offers better performance in case of THD in voltage and current, Speed and Torque control. 'V' is the reference voltage (310 volts) is compared with actual voltage from proposed MLI and the error is applied as input to the ANFIS. The function of ANFIS shown in figure 3 in the proposed drive is minimize error and improves the improve drive performance.

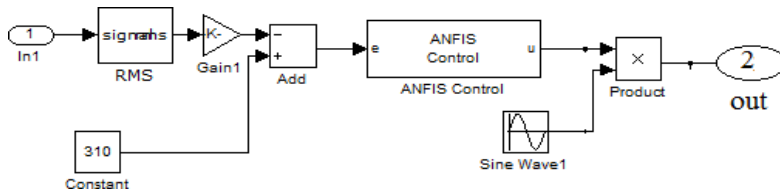

(a)

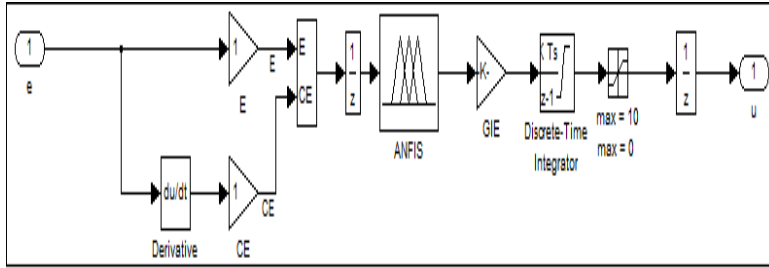

ANFIS control

(b)

Figure 3. (a) Implementation of Adaptive Neuro Fuzzy Inference System (ANFIS) controller in drive circuit (b) ANFIS controller internal representation; E –Error in voltage, CE-Change in error voltage.

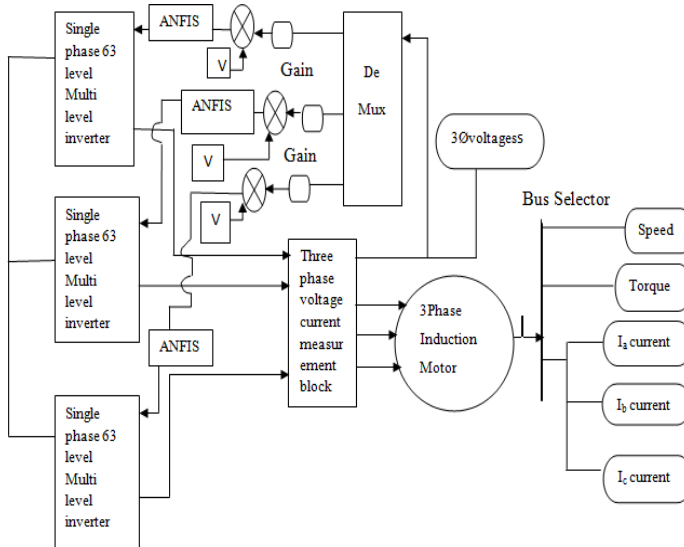
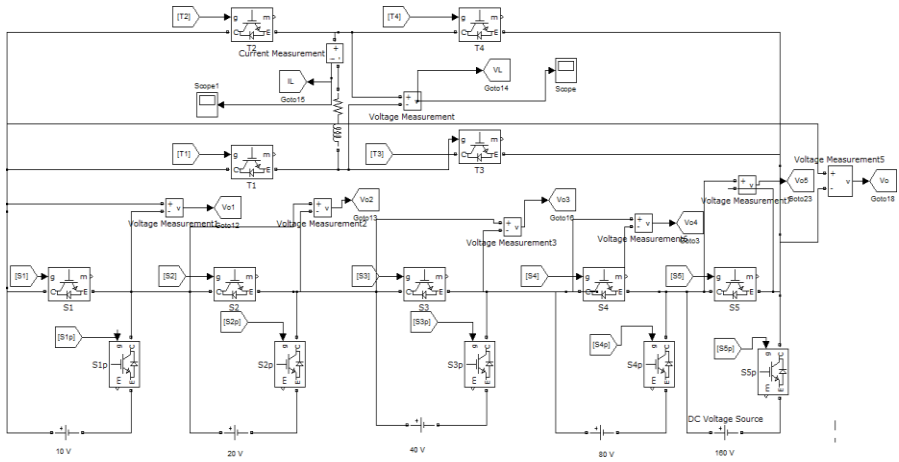

Figure 4. Closed loop control three phase induction motor fed by three phase 63 level MLI through ANFIS controller.

5. Experimental results & analysis

5.1 Proposed Single phase 63 level multilevel inverter



(a)

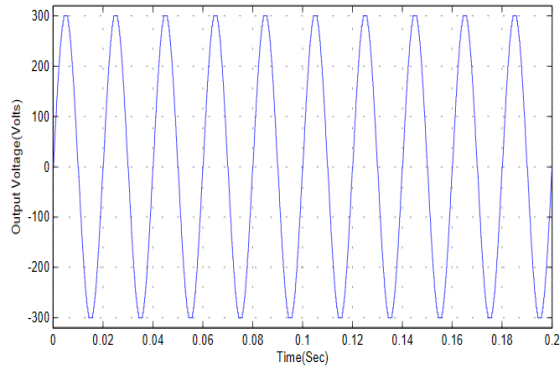

(b)

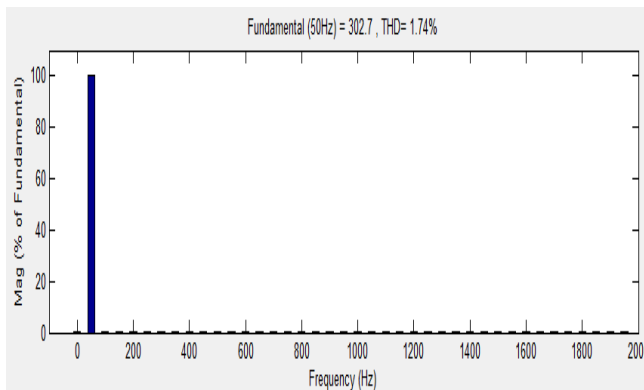

(c)

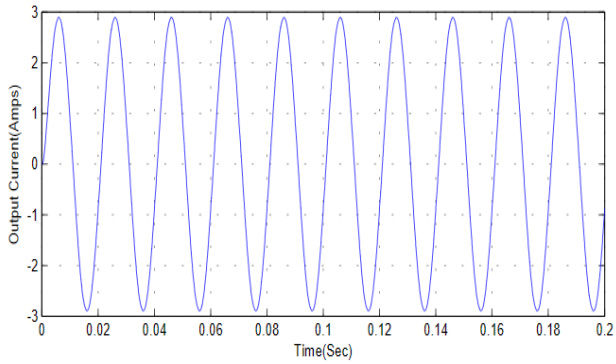

(d)

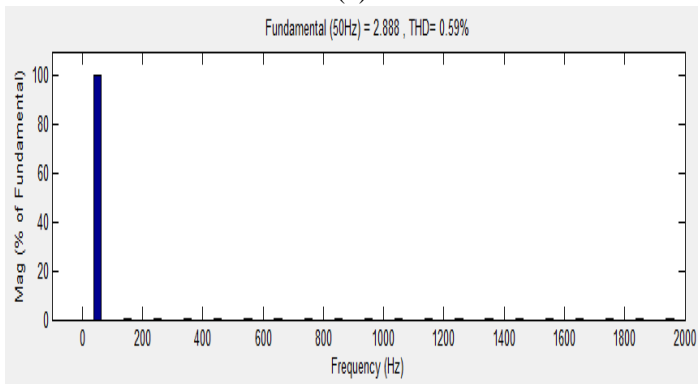

(e)

Figure 5. (a) MATLAB/SIMULINK circuit of the 63 level single phase proposed optimal multilevel Inverter (b) Output voltage (c) Total Harmonics Distortion (1.74%) in voltage (d) Output current of single phase 63 level proposed MLI (e) THD (0.59%) in current.

5.2 Closed loop control of induction motor drive through fuzzy logic controller

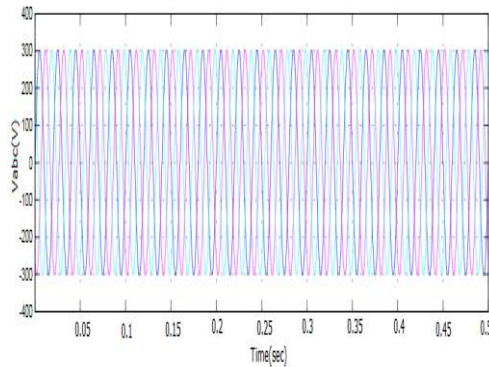

(a)

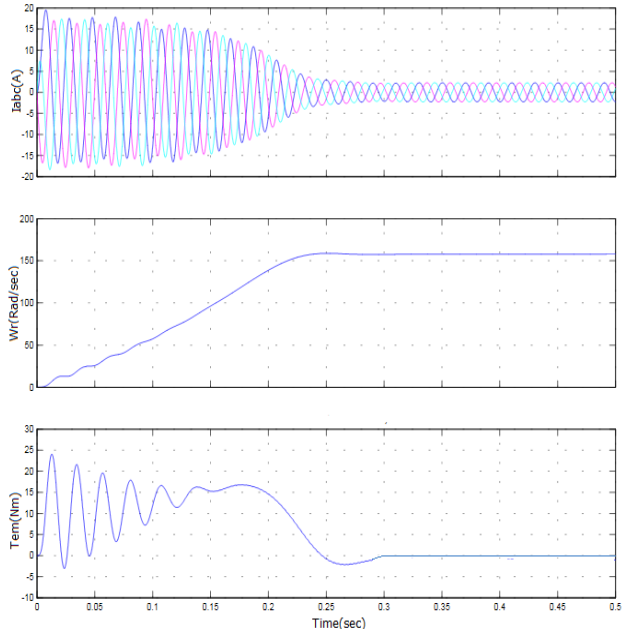

(b)

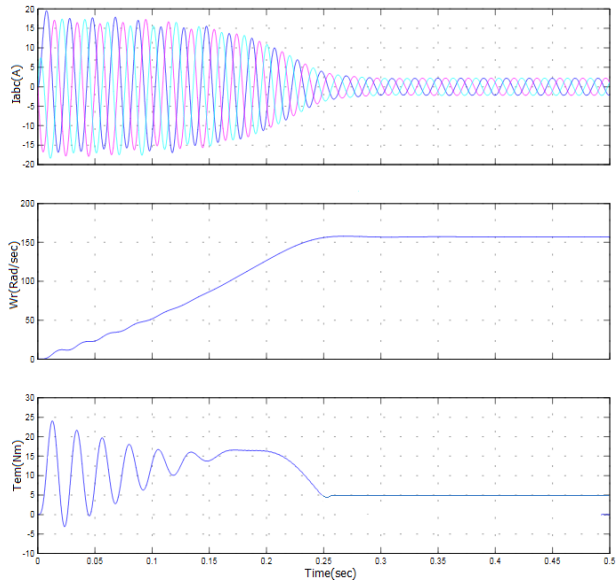

(c)

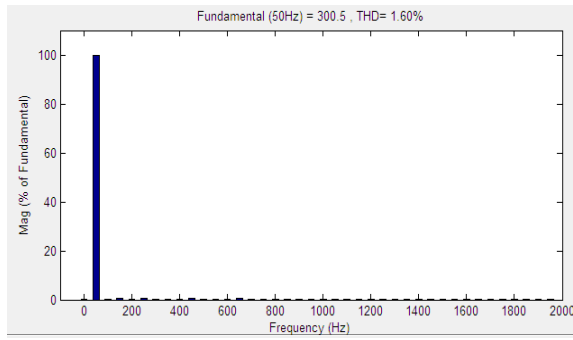

(d)

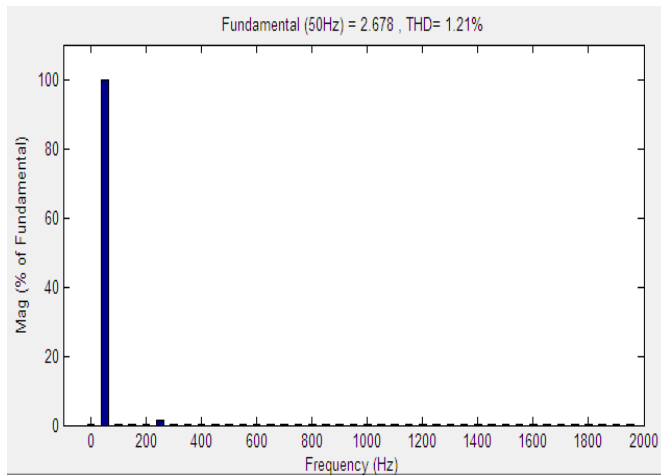

e(i)

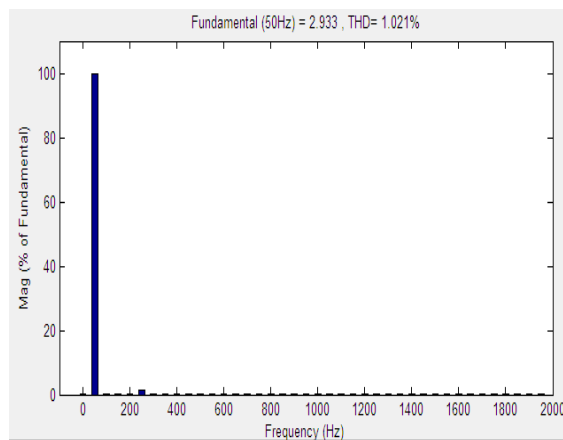

e(ii)

Fig.6: (a) Three phase output voltages, (b) Three phase stator currents and rotor speed and torque under no load condition, (c) Three phase stator currents and rotor speed and torque under applied load (5 Nm) condition,(d) THD of three phase voltages (e) THD of three phase currents (i) No load (ii) Load 5Nm case.

5.3 Closed loop control of induction motor drive through ANFIS

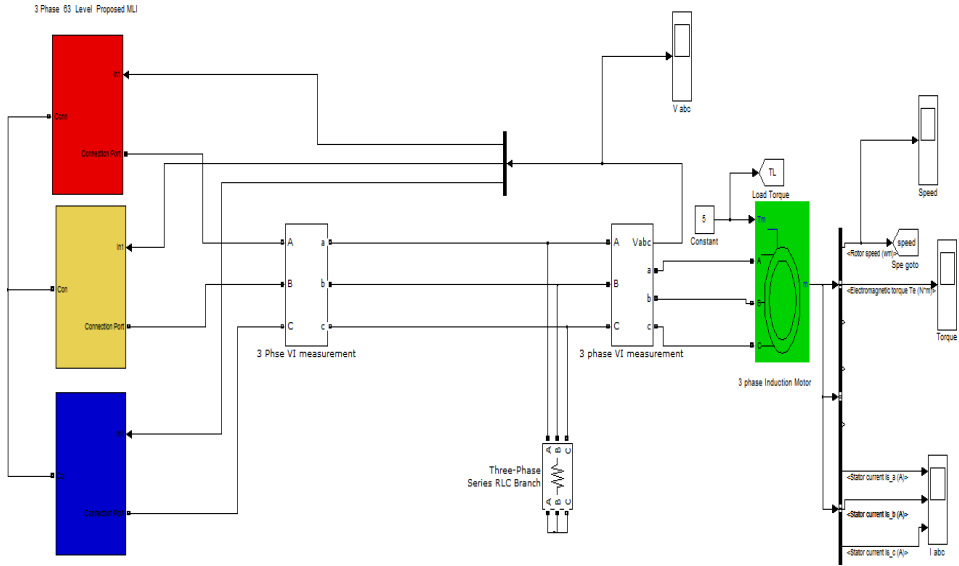

(a)

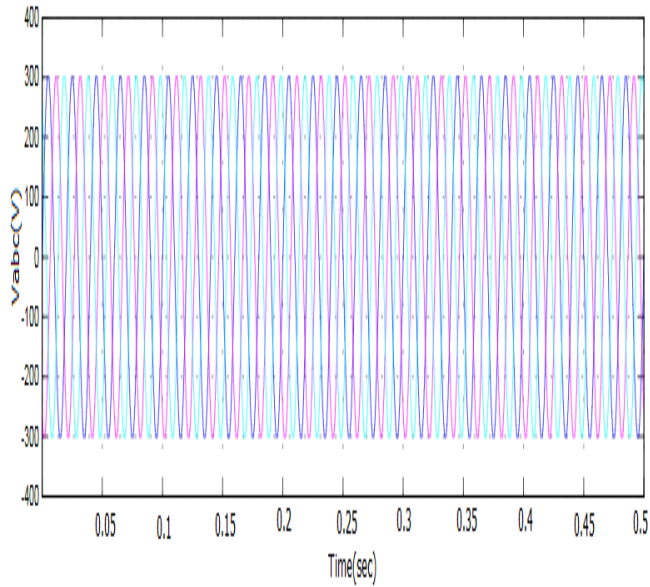

(b)

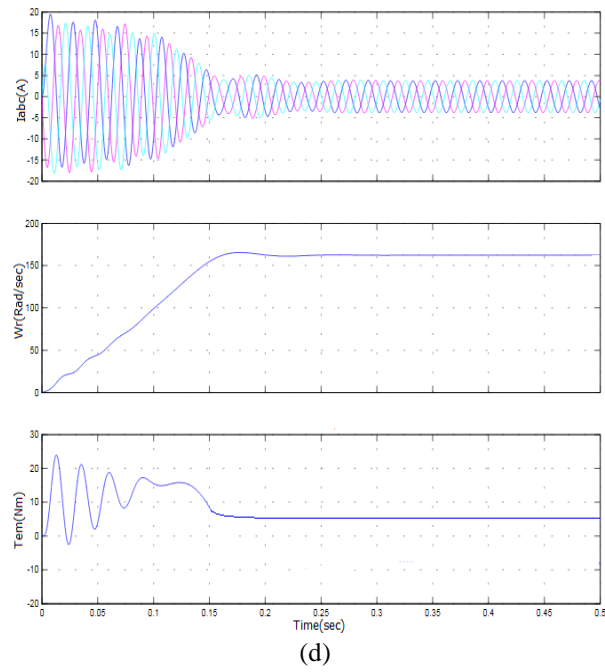
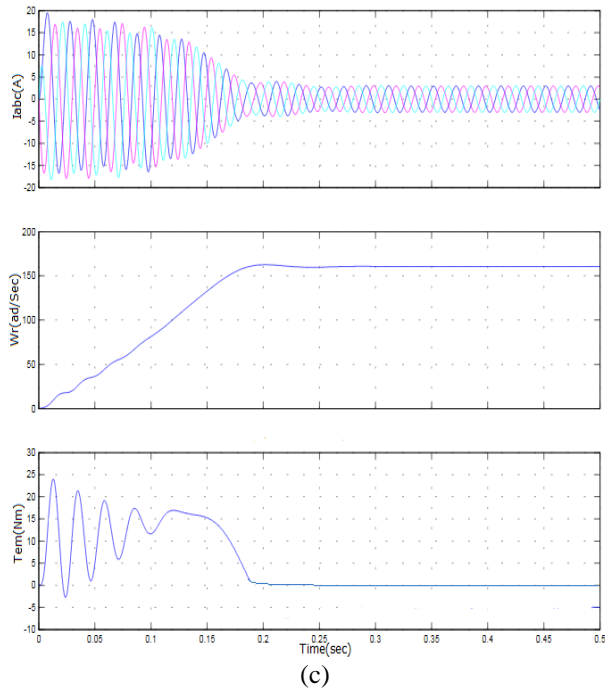

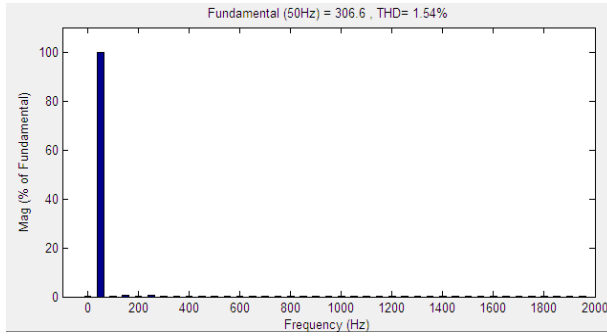

(e)

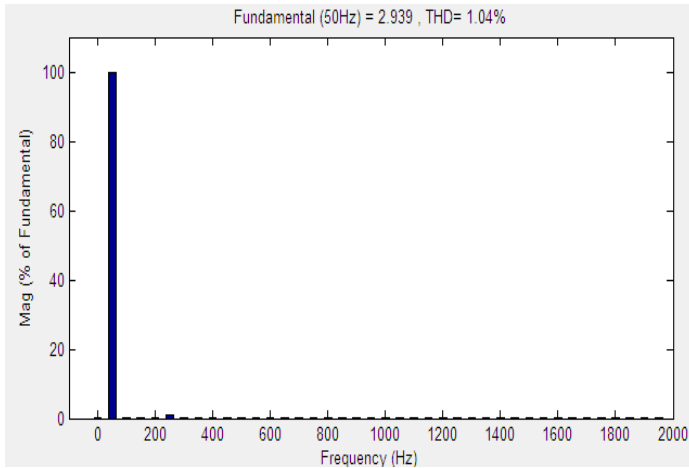

(f)-(i)

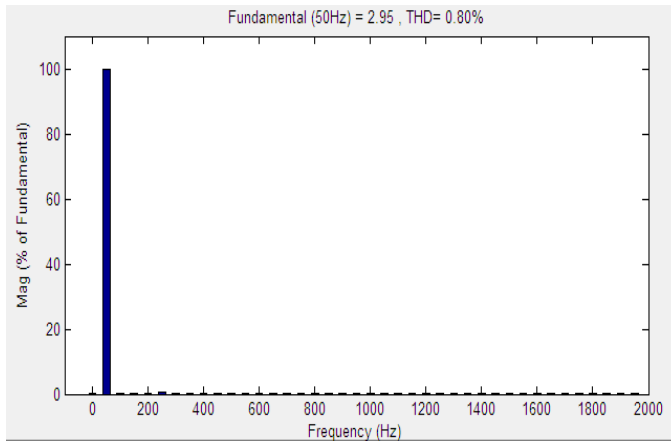

(f)-(ii)

Fig. 7: (a) MATLAB/SIMULINK Closed loop method through ANFIS controller of three phase 63 level MLI fed 3 phase IM drive (b) Three phase output voltages, (c) Three phase stator currents and rotor speed and torque under no load condition, (d) Three phase stator currents and rotor speed and torque under applied load (5 Nm) condition, (e) THD of three phase voltages, (f) THD of three phase currents (i) No load (ii) Load 5Nm case.

Simulation wave forms for closed loop method through FLC of three phase 63 level MLI fed three phase IM drive shown in Fig 6 (a) Three phase output voltages ,(b) Three phase stator currents and rotor speed - electromagnetic torque under no load condition with 0.238 sec rise time and 0.265sec settling time, (c) Three phase stator currents and rotor speed - electromagnetic torque under 5 Nm load condition with 0.270 sec rise time and 0.300sec settling time,(d) THD 1.60% of three phase voltages and its fundamental voltage of 300.5volts , (e)-(i) THD 1.21% of three phase currents and its fundamental current of 2.67A,(e)-(ii) THD 1.02% of three phase currents and its fundamental current of 2.93A under 5Nm load. The maximum torque is 16Nm and speed 154rad/sec under no load case. The electromagnetic torque is 5Nm which is equal to load torque and speed 152rad/sec under load case.

Closed loop control of 3 phase 63 level MLI fed IM drive using ANFIS waveforms regarding - Fig. 7 (b) Three phase output voltages,(c) Three phase stator currents and rotor speed - electromagnetic torque under no load condition with 0.162 sec rise time and 0.180sec settling time, (d) Three phase stator currents and rotor speed - electromagnetic torque under 5 Nm load condition with 0.180 sec rise time and 0.200sec settling time ,(e) THD 1.54% of three phase voltages and its fundamental voltage of 306.6volts , (f)-(i) THD 1.04% of three phase currents and its fundamental current of 2.93A,(f)-(ii) THD 0.80% of three phase currents and its fundamental current of 2.95A under 5Nm load. Therefore in the proposed drive using ANFIS produces more fundamental voltage and current, better speed torque control and less THD in voltage and current when compared to drive with FLC in closed loop control system as shown in Table 3. The maximum torque is 16Nm and speed 156rad/sec under no load case. The electromagnetic torque is 5Nm which is equal to load torque and speed 154rad/sec under load case.

As the number of levels was increased by using proposed 63 level MLI the output quality also be improved. The proposed 63 level MLI cost is less than existing high level MLI due to cause of less number of switching devices and drivers used in proposed MLI. Similarly proposed MLI offers minimum switching, power losses and low voltage drops Thus by using this proposed MLI with control of Induction motor drive produces better performance.

Table 3. Comparisons between closed loop 63 levels MLI fed Induction motor drive through FLC Controller and ANFIS

	Parameters	Closed loop control of induction motor drive with Fuzzy logic Controller	Closed loop control of induction motor drive with ANFIS controller
	%THD voltage	1.60	1.54
	Fundamental voltage(V)	300.5	306.6
NO Load Case	%THD current	1.21	1.04
	Fundamental current(A)	2.67	2.93
	Speed(rad/sec)	154	156
	Max Torque T_{max} (Nm)	16	16
	Rise time(sec)	0.238	0.162
	Settling time(sec)	0.265	0.180

Load Case ($T_L=5Nm$)	% THD current	1.02	0.80
	Fundamental current(A)	2.93	2.95
	Speed(rad/sec)	152	154
	Torque T_{em} (Nm) (Steady state case)	5	5
	Rise time(sec)	0.270	0.180
	Settling time(sec)	0.300	0.200

APPENDIX

Table 4. Induction motor specifications

Configuration and Parameters	
Mechanical input	Torque(Nm)
Rotor type	Squirrel cage
Reference frame	rotor
Rotor resistance(R_r)	3.6840 Ω
Rotor leakage inductance(L_{lr})	0.0221H
Stator resistance(R_s)	7.4826 Ω
Stator leakage inductance(L_{ls})	0.0221H
Mutual inductance(L_m)	0.4114H
Friction factor	0N-ms
Rated power(P_o)	1.1kW
Rated voltage(V_{rms})	380 V
Rated current	3A
Frequency(F)	50 Hz
Inertia(J)	0.02Kgm ²
No. of poles (P)	4

Conclusion

Proposed optimal MLI is the asymmetrical type and control technique is SPWM implemented. The proposed three phase optimal 63 level MLI is designed by using three individual single phase multilevel inverters. In closed control the drive has been controlled by a FLC controller and ANFIS. Simulation results shows that proposed drive produces more fundamental voltage and current, low THD in voltage and current and better speed torque control done with ANFIS.

References

- [1] J.Rodriguz, J.s Lai and F.Z Pen. Multilevel inverters A survey of topology, control and applications, IEEE Transaction, vol 49, no 4 pp 724- 738, Aug 2002.
- [2] J.H. Kim, S.K.Sul, and P.N. Enjeti. A career based PWM method with optimal switching sequence for a multilevel four-leg voltage source inverter, IEEE Trans Ind App, vol, no 4, pp 1239-1248, July / Aug 2008.
- [3] O. Lopez, J. Alvarez, J.Doval-Gandoy, F.D. Freijedo Nogueiras, A. Lago, and C. M.Penalver. Comparison of the FPGA Implementation of two multilevel Space Vector PWM algorithms, IEEE transaction Electron. vol.55, no.4, pp. Apr, 2008.
- [4] Sergio Daher, Jürgen, Schmid, Fernando, L.M.Antunes. Multilevel Inverter Topologies for Stand Alone PV System, IEEE Member.

- [5] Toufannchadhuri, Alfred Rufer, Peter K. Steimr. The Common Cross-Connected Stage for The 5L ANPC Medium Voltage Multilevel, Fellow, IEEE.
- [6] Anushuman Shukal, Arindam Ghosh and Avinash J. Flying-Capacitor-Based Chopper Circuit for DC Capacitor Voltage Balancing in diode Clamped Multilevel Inverter, Fellow, IEEE.
- [7] M. Manjrekar and T. A. Lipo. A Hybrid Multilevel inverter topology for drive application, in Proc. Appl. Power Electron. Conf., 1998, vol. 2, pp. 523–52.
- [8] Reza Barzegarkhool Hossein Madadi Kojabadi Elyas Zamiry, Naser Vosoughi. Generalized Structure Single Phase Switched Capacitor Multilevel Inverter Using a New Multiple DC Link Producer with Reduced Number of switches, IEEE Trans. power elect. 2005.
- [9] S. Ebastien Mari ethoz. Systematic Design of High Performance Hybrid cascaded multilevel inverter with active voltage balance and minimum switch losses, Member IEEE.
- [10] Ehsan Najafi, Abdul Halm Mohamed. Design and Implementation of a New Multilevel Inverter Topology, Member, IEEE, Senior Member.
- [11] Shengfang, Kai Zhang, And Yaosuo Xue. An Improved Control System for modular Multilevel Converters with New Modulation Strategy and Voltage Balancing Control Fan, Student Member, IEEE.
- [12] Mohamed.S, Zaky and Mohamed K. Metwaly. A Performance Investigation of a Four - switch Three Phase Inverter-Fed IM Drives at Low Speeds Using Fuzzy Logic and PI Controllers, IEEE Trans Power electronics.
- [13] C.K. Lee, Student Member, IEEE, S. Y. Ron Hui, Senior Member, IEEE, and Henry shu- Hung Chung Member, IEEE. A 31 level Cascade Inverter for Power Applications, IEEE transactions on industrial electronics, vol. 49, no. 3, june 2002.
- [14] Xingang Fu, Student Member, IEEE, and Shuhui Li, Senior Member, IEEE. A Novel Neural Network Vector Control Technique for Induction Motor Drive.
- [15] Y. V. Siva Reddy, M. Vijaya Kumar, and T. Brahmananda Reddy. A New Space Vector Pulse width Modulation for Reduction of Common Mode Voltage in Direct Torque Controlled Induction Motor Drive, Iranian journal electrical and computer engineering, vol. 7, no. 1, winter-spring 2008.
- [16] Bolla Madhusudana Reddy, Y.V.Siva Reddy, M.Vijaya Kumar, “Comparison of Closed Loop Optimal High Level Novel Multilevel Inverter fed Induction Motor Drive using PI Controller and Fuzzy Logic Controller”, International Journal of Recent Technology and Engineering (IJRTE), Volume-7 Issue-6, Mar. 2019.

© 2022. This work is published under

<https://creativecommons.org/licenses/by/4.0/>

(the“License”). Notwithstanding the ProQuest Terms and Conditions, you may use this content in accordance with the terms of the License.