

<sup>1\*</sup>Shaik Chانبasha<sup>2</sup>N. Jayakumar<sup>3</sup>N Bhupesh Kumar

# Hybrid Ttloa Model For Simultaneous Distribution Network Reconfiguration And Optimal Placement Of Distributed Generators For Loss Reduction: Validation On Multiple Test Bus Systems And Outage Scenarios



**Abstract** - Objective: The study aims to improve network performance by combining DG and network reconfiguration.

Methods: A hybrid Teamwork-Teaching Learning Optimization Algorithm (TTLOA) is proposed. TTLOA optimizes DG sizing, placement, and network reconfiguration. MATLAB is used for implementation on IEEE\_33, IEEE\_69, IEEE\_119, and Indian\_52 bus systems. The model is evaluated using five outage scenarios.

Results: Near-optimal solutions are obtained for DG sizing and placement. Power loss is minimized by improving the power factor (PF) of DG.

Conclusions: The proposed model effectively enhances network performance through DG and network reconfiguration. It provides valuable insights for practical applications.

**Keywords:** hybrid Teamwork -Teaching Learning Optimization Algorithm (TTLOA), network reconfiguration, sizing and siting of distributed generation (DG), active distribution network, power system, outage scenarios.

## I. INTRODUCTION

The worldwide electric power sectors are going through extensive transformation operations and adjusting to the markets that are unregulated. The vertically integrated systems have undergone a restructuring process and are now separated into distinct entities, which include one or more corporations engaged in the generation, transmission, and distribution of electric power [1, 20]. The idea behind the introduction of competition in power systems is that it will boost this industry's productivity and lower the price of electrical energy for all users. Transmission and distribution are typically regarded as a natural privilege, in contrast to the production and selling of electricity. Users of these networks must bear the expense of transmission and distribution operations [9, 23].

Network use tariffs can be used for allocation, concentrating on their actual impacts on these expenses. Distribution power losses are among the expenses that require budgeting, along with other costs. The fundamental challenge in assigning losses is that each user impact on network losses is complicated by the nonlinearity between losses and supplied power [3]. Transmission lines deliver the electricity produced by power plants to distribution networks. In turn, distribution networks deliver electricity to their clients [18, 19]. Low voltage electricity is frequently delivered to consumers. Approximately 12.8% of the total amount of power generated is lost because of losses, which is on the rise when compared to the transmission system [17].

Power loss for branch currents is often generated by the real and reactive components. Losses brought on by reactive branch current components can occur with network reconfiguration. The network has been redesigned to have lower power losses and a higher voltage profile. Changing the systems topology for efficient operation is a significant aspect that affects network reconfiguration. However, every distribution feeder has a unique combination of loads [2, 12].

<sup>1\*</sup>Assistant Professor, Department of Electrical and Electronics Engineering, Sir C R Reddy College of Engineering, Eluru, west Godavari, and Research scholar in Annamalai University, Annamalai nagar, chitambaram, India

<sup>1\*</sup>Corresponding author email id: bashae7862007@gmail.com

<sup>2</sup>Lecturer, Government Polytechnic College, Ariyalur, Tamilnadu, India

<sup>3</sup>Professor, Department of Electrical and Electronics Engineering, Sir C R Reddy College of Engineering, Eluru, west Godavari, Andhra Pradesh, India.

In an RDN, network reconfiguration entails changing the topology of the system, such as adding or removing nodes, to enhance performance, efficiency, and reliability. The goal is to lessen power losses, voltage drops, and power quality issues, while improving the topology of the network [16, 22].

The process of allocating losses among a RDNs component, like as transformers, conductors, and loads, is known as loss allocation. For the purpose of calculating service costs, billing, and economic planning, loss allocation is required. The load-flow approach, the substation method, and the sequential current injection method are a few of the techniques for assigning losses [25].

The approach is determined by the configuration, complexity, and data accessibility of the network. By adjusting the tie and sectional switches in the distribution network, missing settings can be reduced, and the voltage distribution can be improved [6].

The operating environments would be enhanced, and the hardware capabilities of the system would be fully utilized. Transferring loads from densely loaded locations to spots that are relatively lightly loaded is necessary for configuring the feeder [15].

The challenge of designing a distribution network to lower the overall loss can be a difficult optimization problem with sequential difficulties due to the presence of multiple switching possibilities.

### 1.1. Paper Organization

The paper is organized with literature review in part 2, proposed methodology and problem formulation in part 3, results and discussion in part 4 and the conclusion part in part 5

## II. LITERATURE REVIEW

The earlier literature has a number of research papers that focus on network reconfiguration and loss allocation of RDN employing different methodologies and facets. Below is a review of a few of them.

In [4] have illustrated to reduce costs and increase reliability, it is best to allocate PV panels and WT simultaneously while also reconfiguring RDN. Finding the best optimization factors is crucial. To optimize the advantages of allocating renewable resources and reconfiguring the network, while minimizing losses and dependability costs. Variables for problem optimization include the position, dimension, and the state of the network tie-line switches as well as the PF of the PV and WT.

Developed [7] with no assumptions or approximations, a new branch-oriented LA technique based on circuit theory makes it easier to decompose the power loss equation quantitatively. It allocates the precise number of losses to the network users while taking into account respective load requirements, *PF*, and placement with or without DGs at various load models without normalizing.

Demonstrated [10] the combination of energy not provided (ENS), emissions from DG units and the grid, and the second objective function is defined as network loss. The problem has been made worse by the coexistence of DG units and capacitors, and a detailed strategy for resolving the optimization is required. To handle the complexity of optimal solution, the EABCO approach is used.

Introduced [13] to minimize  $P_{loss}$  in RDN, an effective algorithm for network reconfiguration with DG allocation is needed. Network reconfiguration problems are solved using a modified version of the BPSO method called the Selective Particle Swarm Optimization algorithm (SPSO). By doing a sensitivity analysis, DG units have been allocated. To reduce  $P_{loss}$  and enhancing voltage profiles in distribution systems, a multi-objective function has been developed.

Established [11] an appropriate capacitor and DG sizing, in addition to multi-objective distribution feeder reconfiguration.  $P_{loss}$  and voltage variations, which are the two main aim for conventional distribution systems, are also the main focus of studies on network reconfiguration. However, there has been little focus on reliability and network voltage security.

Explained [14] to decrease real power losses while meeting operating requirements, a unique approach for distribution systems ideal feeder reconfiguration and DG and capacitor unit placement. To achieve a redesigned distribution network, one uses the SPSO. The positioning of DG and capacitors has been addressed using a novel heuristic technique. Here, a brand-new mathematical formula called the PVSC has been developed. The PVSC rating is used to determine the position and size of the candidate bus.

Integrated [5] the optimal network layout by allocating and sizing switchable capacitor banks, and switched capacitor banks. Additionally, the network is reconfigured and capacitor banks are allocated properly while taking into account various loading condition, using the modified PSO technique.

Established [24] the optimization approach based on the Max-Min principle was employed to connect distributed generators in the best possible way while also reconfiguring the distribution network to increase system load capacity (max) and reduce real power loss. To accomplish the suggested goals, two scenarios are used. The improvement of loss mitigation and system load capacity seems to be the subject of Scenario 1.

Utilized [21] a modified flower pollination algorithm to devise a reconfiguration methodology for a distribution network with PV arrays and D-STATCOM. The proposed methodology aimed to minimize  $P_{loss}$ , attain the lowest load balancing index, and maximize the voltage distribution. In this case, PV arrays are thought of as dispersed generating, and D-STATCOM is a FACTS.

Suggested [8] a new chaotic search group method for the distribution network's DG allocation and network reconfiguration. The primary goal was to minimize  $P_{loss}$ . The updated metaheuristic algorithm, CSGA, is an improvement over the original SGA as it combines a chaotic local search strategy to enhance search performance.

#### *A. Problem Statement*

According to recent research, network reconfiguration and loss allocation for RDNs have been the topic of analysis. Over the years, distribution network concerns such as loss allocation and network reconfiguration have been investigated independently. However, switching operations can be carried out either manually or automatically can be used to change the topologies of the distribution networks to lower power loss, boost system security, and improve PQ. Thus, it is necessary to take network reconfiguration and loss allocation into account immediately. Consumers are believed to be responsible for covering losses. Given operational and electrical restrictions, the network reconfiguration problem is presented. By loss allocation and network reconfiguration, the study's main objective is to lower the overall  $P_{loss}$  and voltage variation of the RDN. Additionally, TTLOA scenarios are used to study the bus voltage and stability profiles.

### III. PROPOSED METHODOLOGY

This paper introduces a novel technique to decrease losses in distribution networks by simultaneously utilizing two major approaches: Distribution Network Reconfiguration (DNR) and optimal allocation of DGs. To achieve this objective, the method models the DNR and the determination of the appropriate sizing and placement of DGs as an optimization problem, which seeks to minimize the overall loss of the system while adhering to operational constraints. To resolve this issue, a new hybrid optimization model referred to as Teamwork-Teaching-Learning optimization (TTLOA) model will be introduced in this research work. The proposed TTLOA model is the hybridization of the standard Teamwork Optimization Algorithm (TOA) and Adaptive Teaching-Learning-Based Optimization (TLBO), respectively. To evaluate the proposed methodology, it will be tested on four different power systems: IEEE\_33 bus, IEEE\_69 bus, IEEE\_119 bus, and Indian\_52 bus. To ensure the validity of the proposed model, it will be evaluated using five different cases that represent different outage scenarios.

Case 1 refers to bus outages, which occur due to faults that result in buses being disconnected from the system. Case 2 represents line outages that result from transmission line faults, under asymmetrical and symmetrical. In Case 3, the algorithm will be evaluated under the simultaneous occurrence of bus and line outages. Case 4 deals with DG outages that occur when the sources are unable to produce the required power due to input inefficiencies, leading to power transients.

The proposed methodology will be tested on each of the four bus systems by applying the different cases to validate its performance. The model will aim to minimize total system loss while considering operation constraints, thereby reducing the overall network loss. The proposed method will provide an effective approach to the simultaneous optimization of these two approaches for reducing distribution network loss.

#### *A. Problem Formulation*

Integration of network reconfiguration with DG installation can lead to reduced power losses, enhanced voltage stability, improved network efficiency, and increased supply reliability. Depiction of a distribution system featuring DG are shown in the Fig. 1. The function that defines the objective of the optimization problem can be stated as follows.

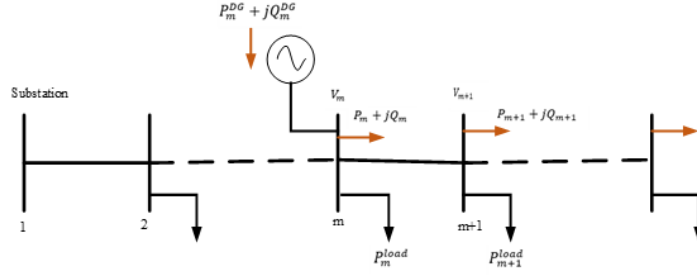

Fig. 1: Depiction of a distribution system featuring DG

i. Power flow equations

$$P_{m+1} = P_m - P_{m+1}^{load} - R_k \times \frac{P_m^2 + Q_m^2}{|V_m|^2} \quad (1)$$

$$Q_{m+1} = Q_m - Q_{m+1}^{load} - X_k \times \frac{P_m^2 + Q_m^2}{|V_m|^2} \quad (2)$$

$$|V_{m+1}|^2 = |V_m|^2 - 2(R_k P_m + X_k Q_m) + (R_k^2 + X_k^2) \frac{P_m^2 + Q_m^2}{|V_m|^2} \quad (3)$$

here the apparent power is  $P_m + jQ_m$  injected at node m, the demanded apparent power is  $P_{m+1}^{load} + jQ_{m+1}^{load}$ , mth node voltage is  $V_m$  and the impedance of the kth line is  $Z_k = R_k + jX_k$ .

ii. Distributed generation-based smart inverters

$$\sqrt{(P_m^{DG})^2 + (Q_m^{DG})^2} \leq S^{DG}, m \in K^{DG} \quad (4)$$

$$-\tan(\cos^{-1} \beta_{min}) \times P_m^{DG} \leq Q_m^{DG} \leq \tan(\cos^{-1} \beta_{min}) P_m^{DG}, m \in K^{DG} \quad (5)$$

here  $P_m^{DG}$  and  $Q_m^{DG}$  are the injected DG P and Q at the mth node.  $S^{DG}$  is the maximum DG capacity and  $K^{DG}$  is the DG node set

iii. Fast voltage stability index (FVSI)

FVSI is used to gauge how stable a system in an RDN and to suggest possible next steps if stability is compromised.

When FVSI is greater than or equal to one, it shows that the network is getting close to its instability point, and a line with FVSI values close to one also shows that it is getting close to its instability point.

$$FVSI_k = \left| \frac{4Z_k^2 Q_{m+1}}{|V_{m+1}|^2 X_k} \right|, \forall k \in L \quad (6)$$

$$FVSI_{total} = \sum FVSI, \forall k \in L \quad (7)$$

here, L is the line set. The lines with an FVSI should be lower than one and are considered voltage secure.

iv. Power loss

The  $P_{loss}$  equation is given by

$$P_{loss} = \sum_{h=1}^{n_b} \left( \frac{P_m^2 + Q_m^2}{|V_m|^2} \right) \times R_k \quad (8)$$

In this context,  $n_b$  is the total number of distribution system lines, and  $R_k$  is the branch resistance.

B. Objective function

The function to be optimized is the minimization of  $P_{loss}$  given by

$$E_{min} = \min \left\{ g \times \frac{P_{loss}}{P_{loss}^0} + (1 - g) \times \frac{FVSI_{total}}{FVSI_{total}^0} \right\} \quad (9)$$

Here g is the scaling parameter with range [0,1].  $FVSI_{total}^0$  and  $P_{loss}^0$  are the initial FVSI and power loss before DNR and DG allocation

C. Constraints

$$V_m^{min} \leq |V_m| \leq V_m^{max}, \forall m \in K \quad (10)$$

$$FVSI_k < 1, k \in L \quad (11)$$

$$|I_m| \leq I_m^{max}, \forall k \in \quad (12)$$

$$P^{slack} > 0 \quad (13)$$

$V_m^{min}$  and  $V_m^{max}$  are the maximum and minimum voltage magnitudes at the mth node. The rated current of the kth line is  $I_m^{max}$ . The power injected by the substation is  $P^{slack}$  and K is the node-set.

*i.Reconfiguration constraint*

$$N_{node} - N_{branch} = 1 \tag{14}$$

Where the number of nodes is  $N_{node}$  and the number of branches is  $N_{branch}$

*D. Network reconfiguration*

The system operator must choose the most effective reconfiguration topology that preserves the network's radial structure in the event of line faults. This indicates that the network should continue to be organized in a tree-like fashion, with electricity flowing in a single route from the source via the distribution network to the loads. The objective is to maintain network stability and ensure that loads may receive electricity with little disruption.

To solve the DNR problem using the proposed TTLOA, three steps were taken: specifying the number of dimensions, finding the search space for each dimension, and using TTLOA to select the optimal network reconfiguration solution. Since switches can only be in one of two states—open or closed—a binary vector can be used to indicate the status of switches during network reconfiguration. Once the DG allocations are determined the DGs are placed in the optimal position. Then the reconfiguration process takes place.

The number of tie switches in a network reconfiguration is given by

$$N_{TS} = b - n + 1 \tag{15}$$

where  $N_{TS}$  is the number of tie switches,  $b$  and  $n$  are the number of branches and nodes in the bus system

The steps of the method are as follows, and this part shows how it was used to solve the NR and DG

**Allocation Problem:**

To specify the number of dimensions, the DN was designed as a multi-loop circuit which runs in an open loop to ensure that the network is in the form of a tree. To do this, all tie switches were closed, which allowed us to obtain the number of loops. This information was then used in the optimization process to find the optimal network topology.

*E. Hybrid teamwork Teaching Learning Optimization Algorithm*

**Step 1. Initialization**

To initialize the population  $Y$ , a search space that is constrained by a matrix of  $S$  rows and  $C$  columns is randomly created. To assign a random value to the  $p$ th learner's  $q$ th parameter, the following equation is employed.

$$y_{(p,q)}^0 = y_q^{min} + rand \times (y_q^{max} - y_q^{min}) \tag{16}$$

$S$  is the class size,  $C$  is the number of courses provided to the learners,  $MAXITR$  is the maximum number of iterations,  $rand$  is the uniformly distributed random variable in  $[0, 1]$ ,  $y_q^{max}$  and  $y_q^{min}$  are the max and min limits of the  $q$ th parameter, respectively.

**Step 2. Random Generation**

The generation  $g$  for the  $i$ th learner is given by

$$Y_p^g = [y_{(p,1)}^g, y_{(p,2)}^g, y_{(p,3)}^g, \dots \dots y_{(p,q)}^g, \dots \dots y_{(p,c)}^g] \tag{17}$$

**Step 3. Fitness evaluation**

$$fitness = E_{min}$$

were,

$$E_{min} = \min \left\{ g \times \frac{P_{loss}}{P_{loss}^0} + (1 - g) \times \frac{FVSI_{total}}{FVSI_{total}^0} \right\} \tag{18}$$

**Step 4: Adaptive inertia weight  $w_{inertia}$**

The TLBO optimization algorithm relies on the inertia weight parameter to achieve equilibrium between the act of exploring new possibilities and exploiting existing knowledge. This parameter has a significant impact on the algorithms convergence rate and solution quality. Hence, selecting the appropriate value for the inertia weight is essential to obtain optimal results in TLBO. The weight factor selected for Linear time-varying systems that experience random changes with chaotic behavior, which involves a reduction in inertia weight, is determined by the following equation.

$$\omega_{inertia} = \frac{k_{max} - k_i}{k_{max}} [\omega_{max} - \omega_{min}] + \omega_{min} * x \tag{19}$$

Where  $x = 4 * d * (1 - d)$ , and  $d$  is the random initial value in the range of  $[0.1]$ .

**Step 5. Optimal Inertia weight using Teamwork Optimization**

The inertia weight is optimized using a teamwork algorithm.

$$\omega_{inertia} = optimal(TW) = \omega_{tw} \quad (20)$$

Step 6. Teacher phase

At generation  $g$ , the mean parameter  $M^g$  is used to denote the average value of a particular trait among all individuals in the learner population of the class.

$$M^g = [m_1^g, m_2^g, \dots, m_q^g, \dots, m_c^g] \quad (21)$$

The teacher selection step comprises selecting the person with the lowest objective function value and giving them the teacher  $Y_{teacher}^g$  in order to support the improvement of the learner population. A weighted differential vector based on the existing and desired mean parameters is used in the teacher phase to change the population mean of the learners towards the instructor. The performance of the algorithms can be increased thanks to the fresh set of upgraded learners produced by this method.

$$Y_{new_p}^g = w_{tw} * Y_p^g + rand \times (Y_{teacher}^g - T_F M^g) \quad (22)$$

$w_{tw}$  is the teamwork-optimized weighted inertia factor. The teaching factor  $T_F$  is utilized as a decision-making parameter to assess the magnitude of mean value change in the teacher phase.  $T_F$  value, which can either be 1 or 2, is chosen at random with an equal probability as

$$T_F = round[1 + rand(0,1)\{2 - 1\}] \quad (23)$$

If  $Y_{new_p}^g$  is identified as a superior learner compared to  $Y_p^g$  in the current generation  $g$ , it will substitute the weaker  $Y_p^g$  in the matrix.

Step 7. Learner phase

The learner phase promotes knowledge improvement by facilitating learner interactions through a random selection process. Choosing a particular learner  $Y_p^g$  and randomly selecting another  $Y_a^g$  ( $i \neq a$ ), the algorithm updates the  $p$ th parameter of the  $Y_{new}$  matrix, thereby improving learner knowledge.

$$Y_{new_p}^g = \begin{cases} Y_p^g + rand \times (Y_p^g - Y_a^g), & \text{if } f(Y_p^g) < f(Y_a^g) \\ Y_p^g + rand \times (Y_a^g - Y_p^g), & \text{otherwise} \end{cases} \quad (24)$$

Step 8. Return the best solution

Step 9. Termination

Once all  $MAXIT$  iterations have been performed, the algorithm is terminated. Otherwise, go to step 4. Flowchart for Hybrid TTLOA are shown in the Fig. 2.

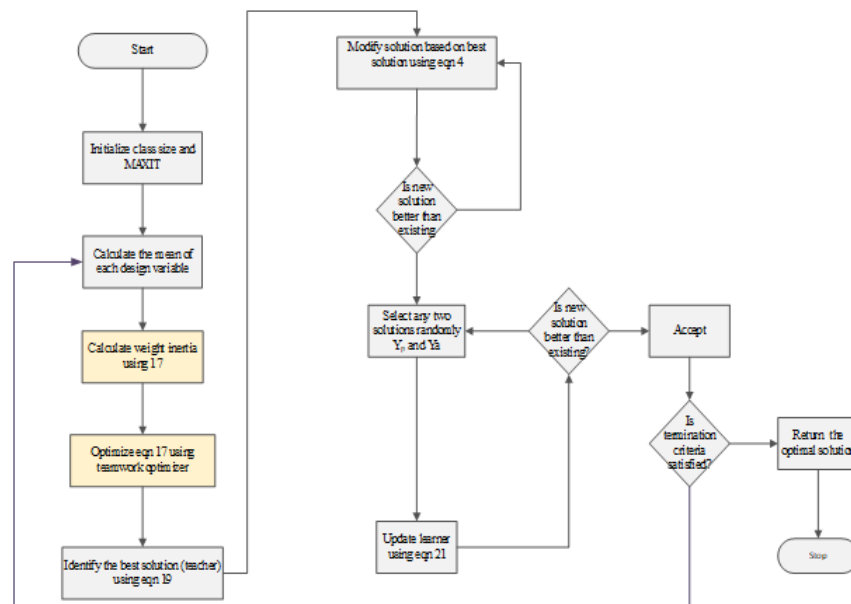

Fig. 2: Flowchart for Hybrid TTLOA

i. Network reconfiguration with TTLOA

The following steps make up the algorithm for solving the NR and DG allocation problem:

- Define the input data, which consists of network data like  $R, X, P_{load}, Q_{load}$  and tie switches.

- Calculate the power flow in the network and generate starting random values for tie switches, DG locations, and sizes.
- Employ TTLOA to identify the ideal network design.
- Utilize TTLOA to determine the optimal network reconfiguration
- Return the outcomes of the optimization procedure.

IV.RESULTS AND DISCUSSION

The proposed Hybrid TTLOA model for network DG allocation is implemented in MATLAB, the results are tested and validated in four different bus system. The proposed Hybrid TTLOA reduces the  $P_{loss}$  in RDS by optimizing the feeder connections subsequent to the optimal allocation of DG units. The outcome is compared with the existing methods when two DGs are connected such as Teamwork Optimization Algorithm (TOA), TLBO and PSO. The proposed methodology was subjected to testing in four distinct cases, which are enumerated below:

**Case 1: Bus outages**

Bus outages refer to instances where buses become disconnected from the power system as a result of faults.

**Case 2: Line Outages**

Line outages are disruptions in the power transmission lines caused by faults, which can be either asymmetrical or symmetrical in nature.

**Case 3: Bus and Line Outages**

The performance will be evaluated under both line and bus outages.

**Case 4: DG outages**

DG outages refer to situations where the power sources are unable to generate the necessary power due to input inefficiencies, resulting in power transients.

A.. Performance evaluation of IEEE\_33 bus system

The performance evaluation of TTLOA approach is given below

**Table 1:** Comparison of algorithms based on different factors when utilizing the hybrid TTLOA model with two interconnected DGs

	Proposed TTLOA	TOA	TLBO	PSO
$P_{loss}$	123.5159	127.9351	129.9713	131.3406
$Q_{loss}$	81.5963	85.6912	86.6028	92.582
No. of DGs	2	2	2	2
Optimal DG Location	32 17	10 16	14 31	32 29
Optimal DG Size P (kW)	476 80	494 199	267 417	291 255
Optimal DG Size Q (kVAR)	230.5373 38.74577	239.2551 96.3801	129.314 201.9623	140.9377 123.5021
$V_{min}$	0.93123	0.88592	0.88057	0.85833
$V_{min}$ Bus Number	18	33	18	18
$V_{max}$	0.99749	0.98034	0.97605	0.90313
$V_{max}$ Bus Number	2	2	2	2

Table 1 compares various factors using different algorithms in conjunction with the hybrid TTLOA model when two DGs are linked. The proposed method shows reduction in both  $P_{loss}$  and  $Q_{loss}$  when the optimal position of DGs is in buses 32 and 17. The optimal sizing of DGs at bus 32 and 17 are 476kW,230kVAR and 80 kW, 38 kVAR. The power handling capacity at bus 17 is considerably low compared to other methods.

**Table 2:** IEEE\_33 bus system with 2, 3 and 4 DGs

	Without DG	With DG-2	With DG-3	With DG-4
$P_{loss}$	202.6771	145.3894	97.336	97.2705
$Q_{loss}$	135.141	96.1196	65.0358	64.4592

Number of DG	NIL	2	3	4
Optimal DG Location	NIL	10 31	28 17 30	14 7 6 22
Optimal DG Size P KW	NIL	261 146	341 145 377	401 397 227 272
Optimal DG Size Q KVAR	NIL	126.4081 70.71103	165.1538 70.22671 182.5894	194.2132 192.2759 109.9411 131.7356
$V_{min}$	0.91306	0.92899	0.94242	0.93744
$V_{min}$ Bus Number	18	18	18	33
$V_{max}$	0.99703	0.99737	0.99773	0.99977
$V_{max}$ Bus Number	22	22	22	22

Table 2. compares the performance of a power system without distributed generation (DG) and with DG of different sizes and numbers. As the number and size of DGs increase, the  $P_{loss}$  and  $Q_{loss}$  decreases, indicating that DGs can help to reduce  $P_{loss}$  in a power system. The table shows the optimal allocation and DG sizing for each scenario. With 3 DGs, the optimal placement are buses 28, 17, and 30, and the optimal sizes are 341 KW, 145 KW, and 377 kW for DG1, DG2, and DG3, respectively. The  $V_{min}$  and the corresponding bus number improve as the number and size of DGs increase, indicating that DGs can help to improve voltage profiles in a power system. The  $V_{max}$  and the corresponding bus number also improve as the number and size of DGs increase, indicating that DGs can help to prevent overvoltage issues in a power system. In summary, the table demonstrates the benefits of using DGs to reduce  $P_{loss}$  and improve voltage distribution in a power system. The optimal placement and DG sizing can be determined under mathematical optimization techniques.

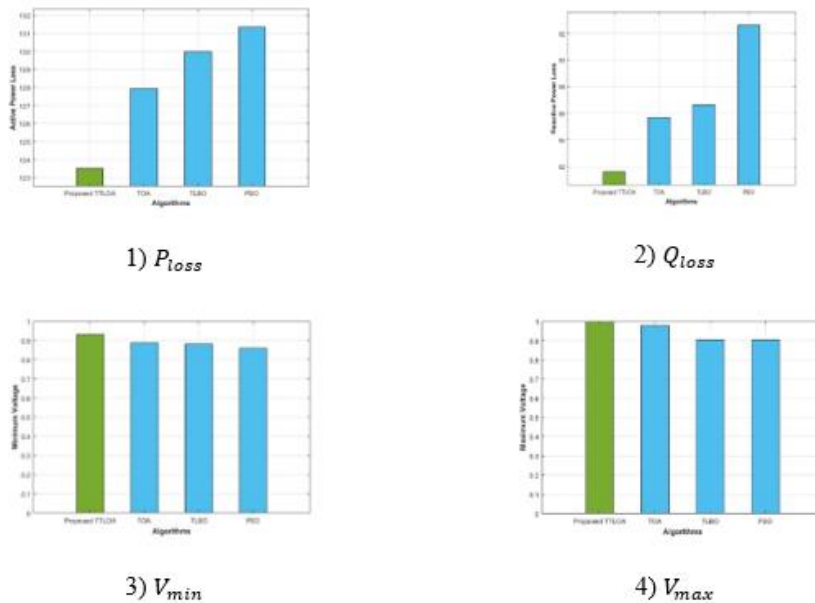

Fig. 3: Comparison of 1)  $P_{loss}$ , 2)  $Q_{loss}$  3)  $V_{min}$  and 4)  $V_{max}$  in IEEE\_33 bus system

From the above Fig. 3 shows the comparison diagrams the proposed hybrid TTLOA has proven to reduce the  $P$  and  $Q$  loss to 123.5 kW and 81.7 kVAR. Also, the  $V_{min}$  and the  $V_{max}$  is maintained to be high compared to all other methods.

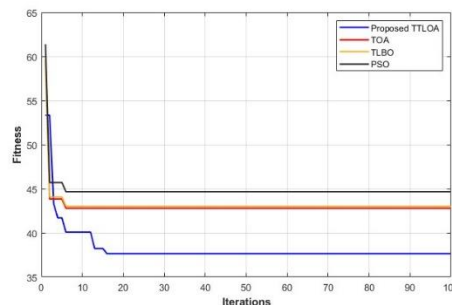
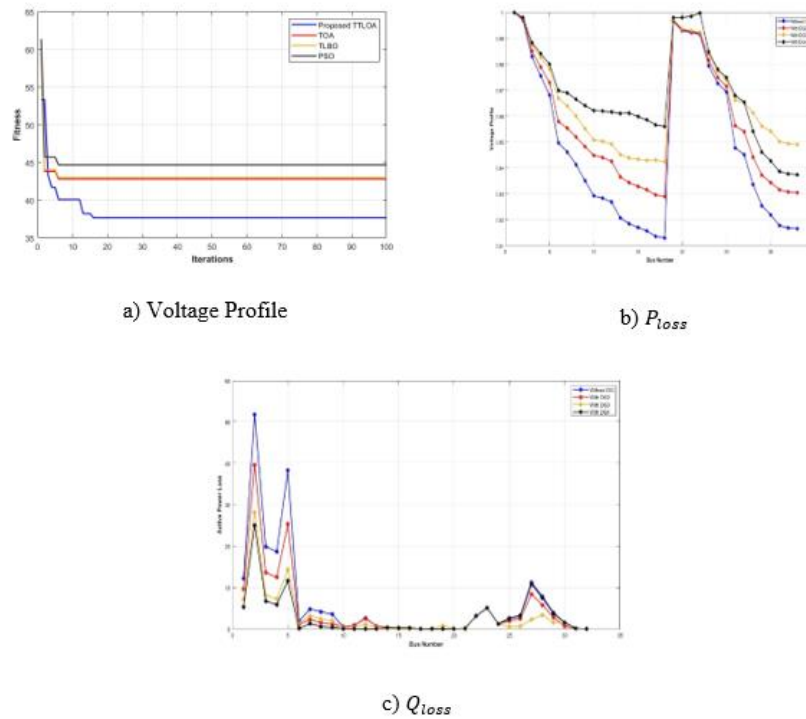

Fig. 4:  $P_{loss}$  Vs Iterations curve in IEEE\_33 bus system

The  $P_{loss}$  minimization function has shown to be reduced to a great extent in each iteration compared to other methods. (Fig. 4)



**Fig. 5:** Comparison of a) Voltage Profile, b)  $P$  loss and c)  $Q$  loss of IEEE\_33 bus system when 2, 3 and 4 DGs are connected

Fig. 5a) shows the voltage profile when 2,3,4 DGs are connected. In Fig. 5b) and in Fig. 5c) the  $P$  and  $Q$  loss are minimum when 4 DGs are connected to the IEEE-33 bus system.

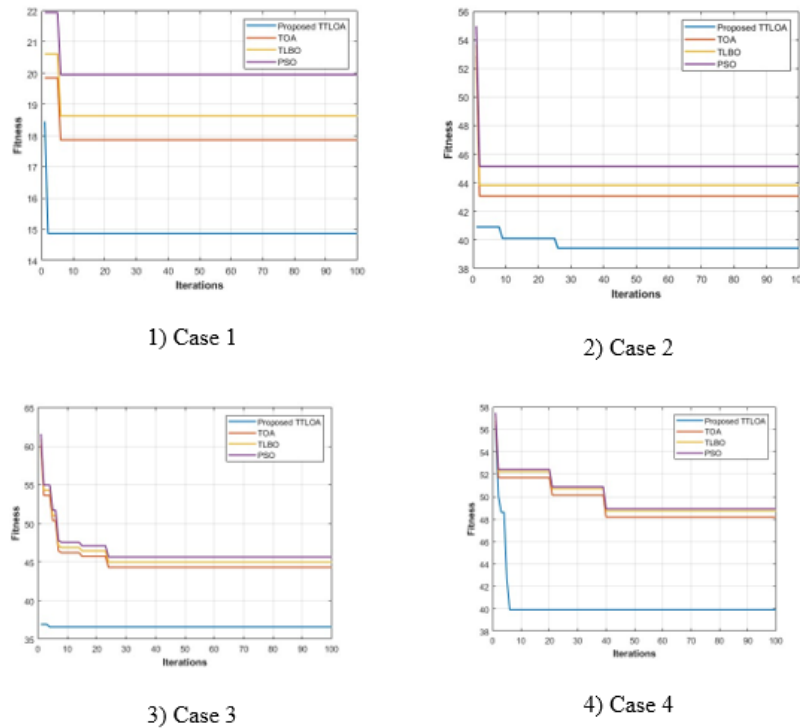

**Fig. 6:** Comparison of TTLOA with TOA, TLBO and PSO for 1) Case 1, 2) Case 2, 3) Case 3, 4) Case 4 in IEEE\_33 bus system

The  $P_{loss}$  reduction using hybrid TTLOA is shown in Fig. 6. In case 1, fault occurs at bus 22, in case 2 fault occurs at line 11. For case 3, fault occurs simultaneously at bus 22 and line 11. In case 4 the DGs at 22, 25, 33, and 18 are disconnected due to fault. In all the above cases the proposed hybrid TTLOA provides minimum  $P_{loss}$  as shown in Fig. 6

*B. Performance evaluation of IEEE-69 bus system*

The performance analysis of the hybrid TTLOA is given below. Table 3. Provides the various parameter values obtained.

**Table 3:** Comparison of TTLOA with existing techniques in IEEE\_69 bus system

	Proposed TTLOA	TOA	TLBO	PSO
Active Power Loss (kW)	173.4724	177.2895	180.7287	183.0419
Q Loss (kVAR)	79.9649	83.9445	85.0682	85.9992
Number of DG	2	2	2	2
Optimal DG Location	24 58	61 19	61 11	26 55
Optimal DG Size (P kW)	32 309	349 151	421 10	250 233
Optimal DG Size (Q kVAR)	15.49831 149.6555	169.0284 73.13264	203.8996 4.843221	121.0805 112.8471
$V_{min}$	0.92077	0.89899	0.85874	0.81537
$V_{min}$ Bus Number	65	65	65	65
$V_{max}$	0.99997	0.99477	0.97446	0.89265
$V_{max}$ Bus Number	2	2	2	2

The table presents the results of an analysis of a power system with two DGs in IEEE\_69 bus system. TTLOA with TOA, TLBO and PSO methods were compared. The results show that TTLOA placed the DGs at bus 24 and 58, with sizes of 32 kW and 15.49831 kVAR, respectively. The  $P_{loss}$  and  $Q_{loss}$  obtained from TTLOA were 173.4724 kW and 79.9649 kVAR, respectively. The  $V_{min}$  obtained from TTLOA was 0.92077 at bus 65, which is the highest among all techniques. However, the  $V_{max}$  obtained from TTLOA was 0.99997 at bus 2, which is the lowest among all techniques. The results showed that the PSO technique gave the lowest  $P_{loss}$  and  $Q_{loss}$  of 183.0419 kW and 85.9992 kVAR, respectively, while maintaining the voltage within acceptable limits. The TLBO technique also performed well, with  $P_{loss}$  and  $Q_{loss}$  of 180.7287 kW and 85.0682 kVAR, respectively. The optimal allocation and size of the DGs differed slightly between the techniques. For instance, the PSO technique placed the DGs at bus 26 and 55 with sizes of 250 kW and 121.0805 kVAR, respectively, while the TTLOA technique placed them at bus 24 and 58 with sizes of 32 kW and 15.49831 kVAR, respectively. The study also revealed that PSO gave the highest  $V_{min}$  and  $V_{max}$  values of 0.81537 and 0.89265, respectively, while TTLOA gave the lowest  $V_{min}$  of 0.92077.

**Table 4:** Performance analysis of TTLOA in IEEE\_69 bus system when 2,3,4 DGs are connected

	Without DG	With DG-2	With DG-3	With DG-4
Active Power Loss	224.9606	147.0261	144.5048	111.6908
Q Loss	102.147	68.9149	67.1877	50.4805
Number of DG	NIL	2	3	4
Optimal DG Location	NIL	64 19	61 18 26	64 65 50 14
Optimal DG Size (P kW)	NIL	372 65	267 221 197	294 263 360 174
Optimal DG Size (Q kVAR)	NIL	180.1678 31.48094	129.314 107.0352 95.41145	142.3907 127.3767 174.356 84.27205
$V_{min}$	0.90901	0.93045	0.92534	0.94001
$V_{min}$ Bus Number	65	65	65	61
$V_{max}$	0.99997	0.99997	0.99997	0.99997
$V_{max}$ Bus Number	35	35	35	35

Table 4 presents the performance analysis of TTLOA with 2, 3, and 4 DGs. The table compares the system performance with and without DGs by evaluating the  $P_{loss}$  and  $Q_{loss}$ , optimal DG locations, optimal DG sizes (in kW and kVAR),  $V_{min}$ , and  $V_{max}$ . The results show that the addition of DGs to the system leads to a significant reduction in  $P_{loss}$  and  $Q_{loss}$ . For example, in the case of 4 DGs, the  $P_{loss}$  is reduced from 224.9606

kW (without DGs) to 111.6908 kW (with 4 DGs), representing a reduction of over 50%. Similarly, the  $Q_{loss}$  is reduced from 102.147 kVAR (without DGs) to 50.4805 kVAR (with 4 DGs), representing a reduction of over 50%. TTLOA also provides optimal allocation and DG sizing. In the case of 4 DGs, the optimal locations are found to be buses 64, 65, 50, and 14, and the optimal sizes are 294 kW/142.3907 kVAR, 263 kW/127.3767 kVAR, 360 kW/174.356 kVAR, and 174 kW/84.27205 kVAR, respectively. This information can be useful for system operators to make informed decisions about where to place DGs and what size they should be to optimize system performance. The table also shows that the  $V_{min}$  obtained from TTLOA increases with the DG number in the system, indicating improved voltage stability. For example, in the case of 4 DGs, the  $V_{min}$  is 0.94001, while it is 0.90901 in the system without DGs. However, the  $V_{max}$  remains constant at 0.99997 for all cases, indicating that the addition of DGs does not lead to overvoltage issues.

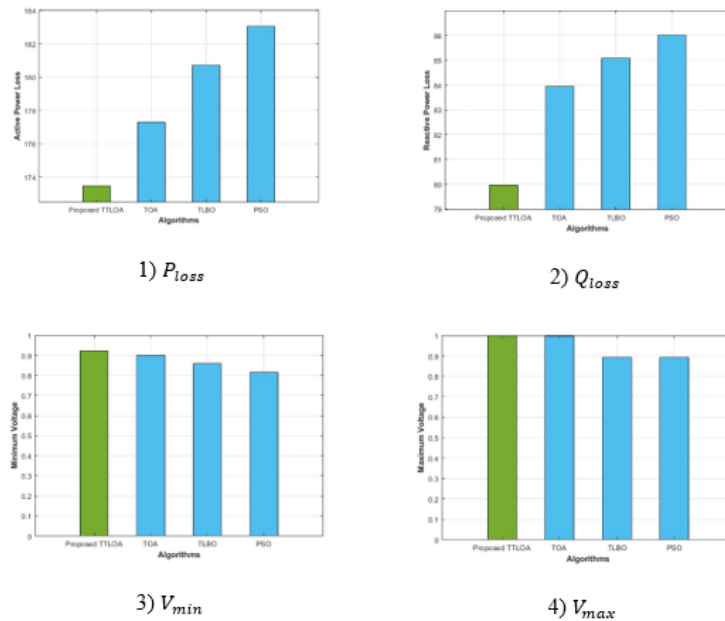

**Fig. 7:** Comparison of 1)  $P_{loss}$ , 2)  $Q_{loss}$  3)  $V_{min}$  and 4)  $V_{max}$  in IEEE\_69 bus system

Fig. 7 compares the performance of TTLOA approach with the existing TOA, TLBO and PSO algorithms. The  $P$  and  $Q$  losses are 173.4724 kW and 79.9649 kVAR respectively which were the lowest among all other methods. Also, the  $V_{min}$  was 0.92077 which occurs at bus 65 and  $V_{max}$  was 0.99997 that occurs at bus 2.

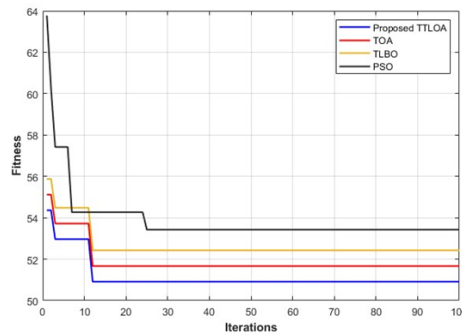

**Fig. 8:**  $P_{loss}$  minimization Vs Iterations curve for IEEE-69 bus system

In Fig. 8 the  $P_{loss}$  minimization function has shown to be reduced to a great extent in each iteration compared to other methods.

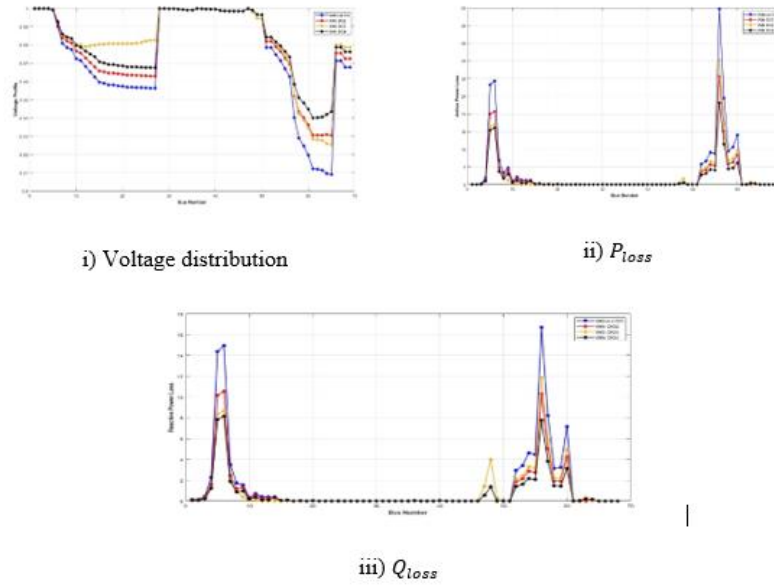

**Fig. 9:** Comparison of i) Voltage Profile, ii)  $P_{loss}$  and iii)  $Q_{loss}$  of IEEE-69 bus system when 2, 3 and 4 DGs are connected

Fig. 9a) shows the voltage profile when 2,3,4 DGs are connected. In Fig. 9b) and in Fig. 9c) the  $P$  and  $Q$  losses are minimum when 4 DGs are connected.

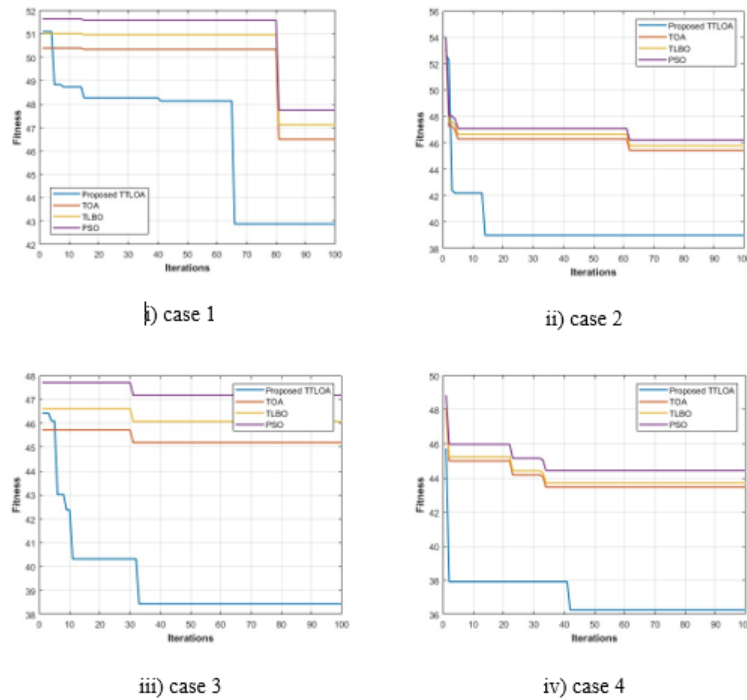

**Fig. 10:** Comparison of TTLOA with TOA, TLBO and PSO for i) case 1, ii) case 2, iii) case 3, iv) case 4 in IEEE\_69 bus system

The  $P_{loss}$  loss reduction using hybrid TTLOA is shown in Fig. 10. In case 1, fault occurs at bus 22, in case 2 fault occurs at line 11. For case 3 fault occurs simultaneously at bus 22 and line 11. In case 4 the DGs at 22, 25, 33, and 18 are disconnected due to fault. In all the above cases the proposed hybrid TTLOA provides minimum  $P_{loss}$  as shown in Fig. 10

*C.Performance evaluation of TTLOA in IEEE-119 bus system*

The performance analysis of the hybrid TTLOA is evaluated and are given below. Table 5. Provides the various parameter values obtained

**Table 5:** Comparison of TTLOA with other techniques in IEEE\_119 bus system

	Proposed TLOA	TOA	TLBO	PSO
Active Power Loss	1204.707	1206.7078	1208.1186	1212.54
$Q$ Loss	825.1017	825.8285	826.2536	829.5727
Number of DG	2	2	2	2
Optimal DG Location	28 78	79 114	103 23	104 71
Optimal DG Size P KW	180 317	496 10	452 109	483 169
Optimal DG Size Q KVAR	87.17798 153.5301	240.2238 4.843221	218.9136 52.79111	233.9276 81.85044
$V_{min}$	0.9	0.88245	0.86269	0.80542
$V_{min}$ Bus Number	63	63	79	93
$V_{max}$	0.99815	0.97327	0.94104	0.92587
$V_{max}$ Bus Number	105	66	105	105

In terms of active power loss, the Proposed TTLOA technique performs the best, with a loss of 1204.707 kW, followed by TOA with a loss of 1206.7078 kW, TLBO with a loss of 1208.1186 kW, and PSO with a loss of 1212.54 kW. Similarly, in terms of  $Q$  loss, Proposed TTLOA also performs the best with a loss of 825.1017 kVAR, followed by TOA with a loss of 825.8285 kVAR, TLBO with a loss of 826.2536 kVAR, and PSO with a loss of 829.5727 kVAR. The Proposed TTLOA technique suggests placing the DGs at buses 28 and 78, with optimal sizes of 180 kW and 87.17798 kVAR, and 317 kW and 153.5301 kVAR, respectively. TOA suggests placing the DGs at buses 79 and 114, with optimal sizes of 496 kW and 240.2238 kVAR, and 10 kW and 4.843221 kVAR, respectively. TLBO suggests placing the DGs at buses 103 and 23, with optimal sizes of 452 kW and 218.9136 kVAR, and 109 kW and 52.79111 kVAR, respectively. Finally, PSO suggests placing the DGs at buses 104 and 71, with optimal sizes of 483 kW and 233.9276 kVAR, and 169 kW and 81.85044 kVAR, respectively.

The  $V_{min}$  and the corresponding bus number are also reported in the table. The Proposed TTLOA technique results in the highest  $V_{min}$  of 0.9, with bus 63 being the corresponding bus number. TOA, TLBO, and PSO techniques result in  $V_{min}$  of 0.88245 (bus 63), 0.86269 (bus 79), and 0.80542 (bus 93), respectively. The  $V_{max}$  and the corresponding bus number are also reported in the table. The Proposed TTLOA technique results in the highest  $V_{max}$  of 0.99815, with bus 105 being the corresponding bus number. TOA, TLBO, and PSO techniques result in  $V_{max}$ s of 0.97327 (bus 66), 0.94104 (bus 105), and 0.92587 (bus 105), respectively.

**Table 6:** Performance analysis of TTLOA in IEEE\_119 bus system when 2,3,4 DGs are connected

	Without DG	With DG-2	With DG-3	With DG-4
$P$ Loss	1473.4799	1212.8915	1145.0124	1137.8364
$Q$ Loss	958.1073	829.071	779.6732	785.0764
Number of DG	NIL	2	3	4
Optimal DG Location	NIL	93 37	100 94 52	62 97 34 103
Optimal DG Size P KW	NIL	441 132	251 430 275	150 303 81 455
Optimal DG Size Q KVAR	NIL	213.586 63.93052	121.5648 208.2585 133.1886	72.64832 146.7496 39.23009 220.3666
$V_{min}$	0.84733	0.9	0.9	0.9
$V_{min}$ Bus Number	104	79	79	79
$V_{max}$	0.99815	0.99815	0.99815	0.99815
$V_{max}$ Bus Number	1	1	1	1

Table 6 compares the performance of TTLOA when different numbers of DGs are connected. The table includes the  $P$  and  $Q$  losses, the number of DGs, the optimal placement and DG sizing, and the minimum and  $V_{max}$ s and their corresponding bus numbers. The results show that with the addition of DGs, the  $P$  and  $Q$  losses

decrease, indicating that the DGs are able to supply some of the load and reduce the losses in the system. As expected, the number of DGs, optimal locations, and sizes vary depending on the number of DGs connected.

When two DGs are connected, the  $aP_{loss}$  reduces from 1473.4799 kW to 1212.8915 kW, and the  $Q$  loss reduces from 958.1073 KVAR to 829.071 KVAR. The optimal locations of the DGs are at buses 93 and 37, with sizes of 441 kW and 132 kW for  $P$  and 213.586 KVAR and 63.93052 KVAR for  $Q$ , respectively. The  $V_{min}$  remains at 0.9 p. u with bus number 79, and the  $V_{max}$  remains at 0.99815 p. u with bus number 105.

When three DGs are connected, the  $P_{loss}$  reduces further to 1145.0124 kW, and the  $Q$  loss reduces to 779.6732 KVAR. The optimal locations of the DGs are at buses 100, 94, and 52, with sizes of 251 kW, 430 kW, and 275 kW for active power, and 121.5648 kVAR, 208.2585 kVAR, and 133.1886 kVAR for  $Q$ , respectively. The  $V_{min}$  remains at 0.9 p.u with bus number 79, and the  $V_{max}$  remains at 0.99815 p.u with bus number 105. When four DGs are connected, the  $P_{loss}$  reduces further to 1137.8364 kW, and the  $Q$  loss increases slightly to 785.0764 KVAR. The optimal allocation of the DGs is at buses 62, 97, 34, and 103, with sizes of 150 kW, 303 kW, 81 kW, and 455 kW for  $P$ , and 72.64832 kVAR, 146.7496 kVAR, 39.23009 kVAR, and 220.3666 kVAR for  $Q$ , respectively. The  $V_{min}$  remains at 0.9 p. u with bus number 79, and the  $V_{max}$  remains at 0.99815 p. u with bus number 105.

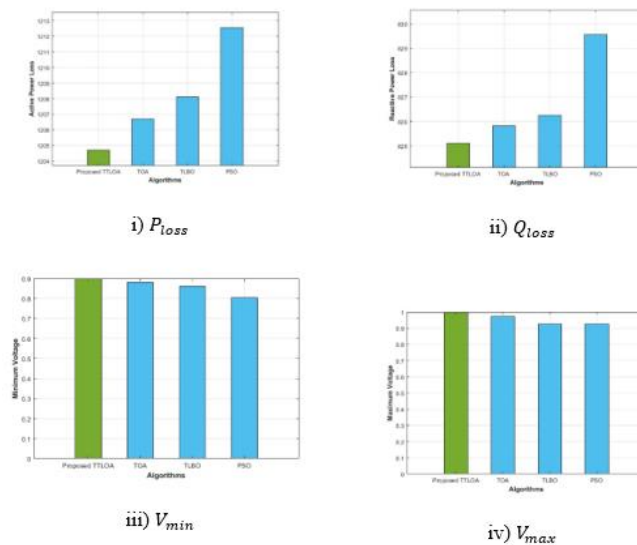

Fig. 11: Comparison of i)  $P_{loss}$ , ii)  $Q_{loss}$  iii)  $V_{min}$  and iv)  $V_{max}$  in IEEE\_119 bus system

Fig. 11 compares the performance of TTLOA approach with the existing TOA, TLBO and PSO algorithms. The  $P$  and  $Q$  losses are 1204.707 kW and 825.1017 KVAR respectively which were the lowest among all other methods. Also, the  $V_{min}$  was 0.9 p. u which occurs at bus 63 and  $V_{max}$  was 0.99815 p. u that occurs at bus 105.

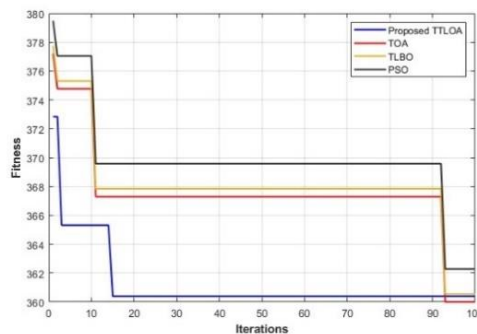
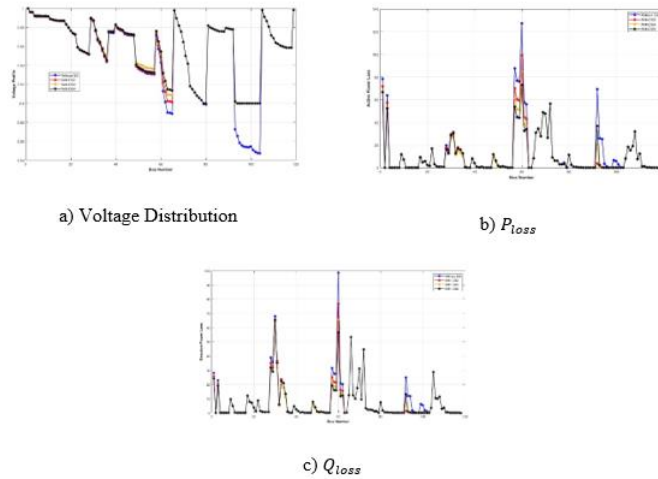

Fig. 12:  $P_{loss}$  minimization Vs Iterations curve for IEEE\_119 bus system

In Fig. 12 the  $P_{loss}$  minimization function has shown to be reduced to a great extent in each iteration compared to other methods.



**Fig. 13:** Comparison of a) Voltage Profile, b)  $P_{loss}$  and c)  $Q_{loss}$  of IEEE-69 bus system when 2, 3 and 4 DGs are connected

Fig. 13 a) shows the voltage profile when 2,3,4 DGs are connected to an IEEE-119 bus system. In Fig. 13b) and in Fig. 13c) the  $P$  and  $Q$  losses are minimum when 4 DGs are connected to the IEEE\_119 bus system.

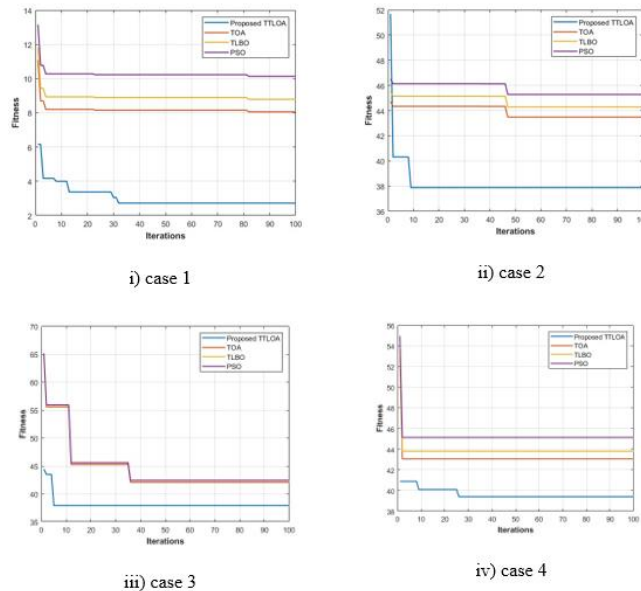

**Fig. 14:** Comparison of TTLOA with TOA, TLBO and PSO for i) case 1, ii) case 2, iii) case 3, iv) case 4 in IEEE\_119 bus system

The  $P_{loss}$  reduction using hybrid TTLOA in is shown in Fig. 14. In case 1, fault occurs at bus 22, in case 2 fault occurs at line 11. For case 3 fault occurs simultaneously at bus 22 and line 11. In case 4 the DGs at 22, 25, 33, and 18 are disconnected due to fault. In all the above cases the proposed hybrid TTLOA provides minimum  $P_{loss}$  as shown in Fig. 14

*D. Performance analysis of TTLOA in Indian 52 - bus system*

The performance analysis of the hybrid TTLOA is evaluated and are given below. Table 7. provides the various parameter values obtained

**Table 7:** Comparison of TTLOA with existing techniques in Indian\_52 bus system

	<b>Proposed TLOA</b>	<b>TOA</b>	<b>TLBO</b>	<b>PSO</b>
$P_{Loss}$	1.6952	4.9189	8.1615	14.5917
$Q_{Loss}$	0.72935	2.9277	3.4084	3.5666
Number of DG	2	2	2	2
Optimal DG Location	49 18	35 39	41 50	35 48
Optimal DG Size P KW	491 261	485 21	470 120	383 33

Optimal DG Size Q kVAR	237.8022 126.4081	234.8962 10.17076	227.6314 58.11865	185.4954 15.98263
$V_{min}$	0.99912	0.97076	0.94284	0.91377
$V_{min}$ Bus Number	44	50	19	50
$V_{max}$	0.99993	0.96127	0.91256	0.85394
$V_{max}$ Bus Number	20	20	20	20

The results suggest that the proposed TLOA algorithm outperforms the other algorithms in terms of minimizing  $P$  and  $Q$  loss, as well as improving voltage levels. It also identifies the optimal location and DG sizing, which can help improve the overall efficiency and stability of the system. Specifically, the TLOA algorithm identifies DG locations at buses 49 and 18, with sizes of 491 KW and 237.8022 kVAR and 261 KW and 126.4081 kVAR, respectively. In terms of voltage levels, the TLOA algorithm results in a  $V_{min}$  of 0.99912 and a  $V_{max}$  of 0.99993, at buses 44 and 20, respectively.

**Table 8.** Performance analysis of TTLOA in Indian \_52 bus system when 2,3,4 DGs are connected

	Without DG	With DG-2	With DG-3	With DG-4
$P_{Loss}$ MW	3.2664	1.9254	1.7342	0.94337
$Q$ Loss MW	1.4053	0.82837	0.74612	0.40587
Number of DG	NIL	2	3	4
Optimal DG Location	NIL	12 50	7 52 48	49 46 10 14
Optimal DG Size P kW	NIL	453 254	239 473 201	394 313 496 264
Optimal DG Size Q kVAR	NIL	219.3979 123.0178	115.753 229.0844 97.34874	190.8229 151.5928 240.2238 127.861
$V_{min}$	0.99858	0.9989	0.99898	0.99931
$V_{min}$ Bus Number	50	44	19	44
$V_{max}$	0.99993	0.99993	0.99993	0.99993
$V_{max}$ Bus Number	1	1	1	1

The results show that the  $P_{loss}$  decreases significantly as the number of DGs increases. When no DG is connected, the  $P_{loss}$  is 3.2664 MW. However, with 2, 3, and 4 DGs connected, the  $P_{loss}$  decreases to 1.9254 MW, 1.7342 MW, and 0.94337 MW, respectively. The same trend is observed for  $Q$  loss, where the loss decreases as the number of DGs increases. The table shows that the optimal allocation for the DGs change as the number of DGs increases. For 2 DGs, the optimal locations are bus 12 and 50, while for 3 DGs, the optimal locations are bus 7, 48, and 52. For 4 DGs, the optimal allocations are bus 10, 14, 46, and 49. This suggests that the optimal location of the DGs depends on the number of DGs in the system. Furthermore, the optimal size of the DGs also changes as the number of DGs increases. For 2 DGs, the optimal sizes are 453 kW and 254 kW for P, and 219.3979 kVAR and 123.0178 kVAR for Q. For 3 DGs, the optimal sizes are 239 kW, 473 kW, and 201 kW for P, and 115.753 kVAR, 229.0844 kVAR, and 97.34874 kVAR for Q. For 4 DGs, the optimal sizes are 394 kW, 313 kW, 496 kW, and 264 kW for P, and 190.8229 kVAR, 151.5928 kVAR, 240.2238 kVAR, and 127.861 kVAR for Q. The  $V_{min}$  increases slightly as the number of DGs increases. When no DG is connected, the  $V_{min}$  is 0.99858, while for 4 DGs, it is 0.99931. The  $V_{max}$  remains constant at 0.99993, regardless of the number of DGs. Performance analysis of TTLOA in Indian \_52 bus system when 2,3,4 DGs are connected are shown in the above Table 8.

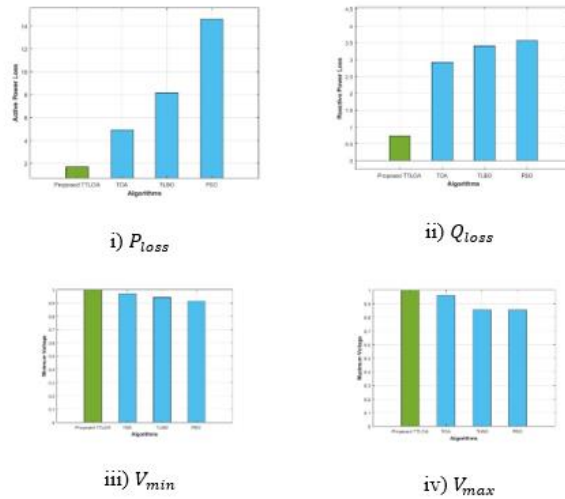

**Fig. 15:** Comparison of i)  $P_{loss}$ , ii)  $Q_{loss}$  iii)  $V_{min}$  and iv)  $V_{max}$  in Indian\_52 bus system

Fig. 15 compares the performance of TTLOA approach with the existing TOA, TLBO and PSO algorithms. The  $P$  and  $Q$  losses are 1695.2 kW and 7293.5 KVAR respectively which were the lowest among all other methods. Also, the  $V_{min}$  was 0.9 p. u which occurs at bus 63 and  $V_{max}$  was 0.99815 p. u that occurs at bus 105.

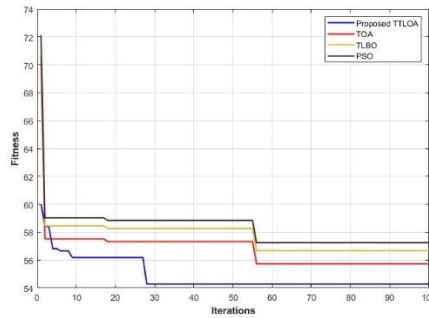

**Fig. 16:**  $P_{loss}$  minimization Vs Iterations curve for Indian\_52 bus system

In Fig. 16 the  $P_{loss}$  minimization function has shown to be reduced to a great extent in each iteration compared to other methods for Indian\_52 bus system.

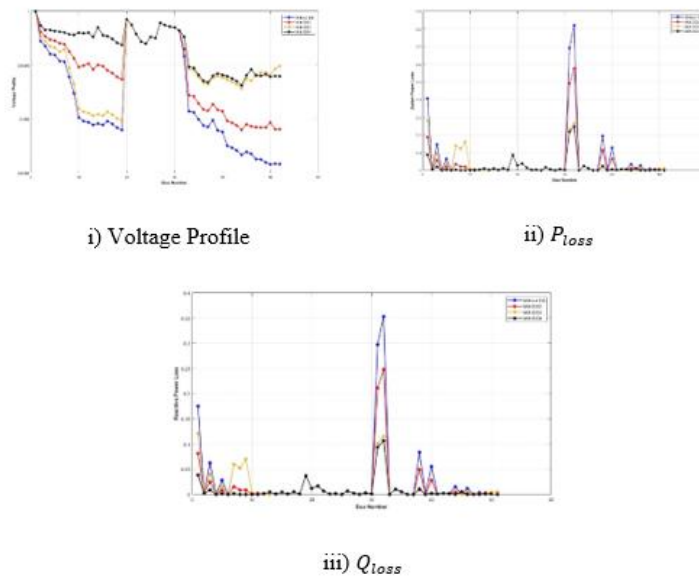

**Fig. 17:** Comparison of i) Voltage Profile, ii)  $P_{loss}$  and iii)  $Q_{loss}$  in Indian\_52 bus system when 2, 3 and 4 DGs are connected

Fig. 17a) shows the voltage profile when 2,3,4 DGs are connected to an Indian\_52 bus system. In Fig. 17b) and in Fig. 17c) the  $P$  and  $Q$  losses are minimum when 4 DGs are connected to the Indian\_52 bus system.

The  $P_{loss}$  reduction using hybrid TTLOA in Indian\_52 bus system is shown in Fig. 14. In case 1, fault occurs at bus 22, in case 2 fault occurs at line 11. For case 3 fault occurs simultaneously at bus 22 and line 11. In case 4

the DGs at 22, 25, 33, and 18 are disconnected due to fault. In all the above cases the proposed hybrid TTLOA provides minimum  $P_{loss}$  as shown in Fig. 14. Comparison of TTLOA with TOA, TLBO and PSO for i) case 1, ii) case 2, iii) case 3, iv) case 4 in Indian\_52 bus system is shown in the Fig. 18.

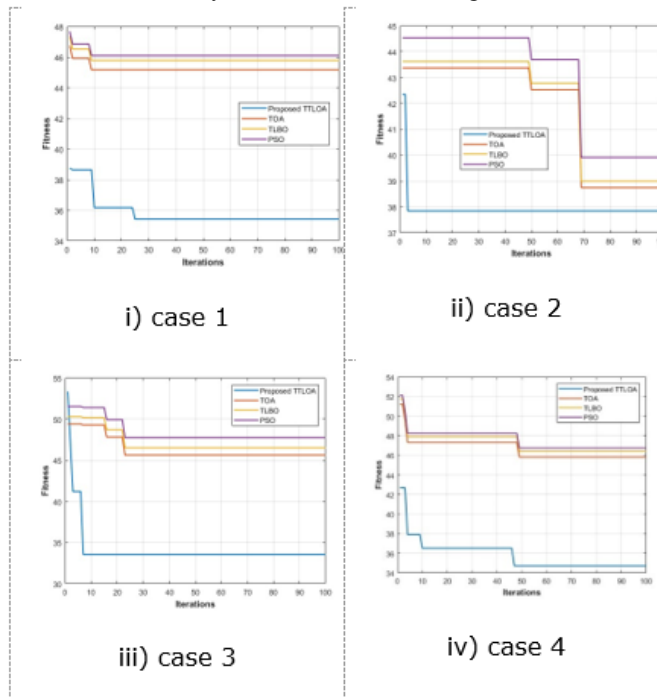

Fig. 18: Comparison of TTLOA with TOA, TLBO and PSO for i) case 1, ii) case 2, iii) case 3, iv) case 4 in Indian\_52 bus system

E. Network reconfiguration

The network reconfiguration with basic loop is shown in Fig. 19. for IEEE\_33 bus system with TTLOA algorithm. IEEE\_33 bus system after reconfiguration is shown in the Fig. 20.

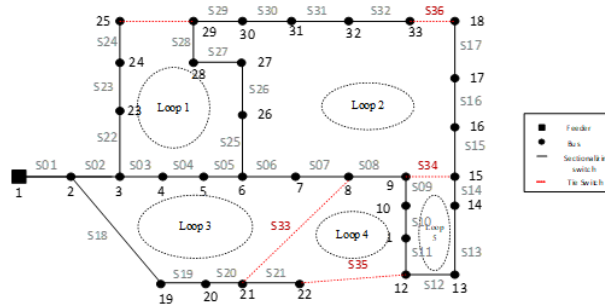

Fig. 19: IEEE\_33 bus system with a basic loop

When a line fault occurs at line 11, the system is reconfigured with the optimal tie switches configuration with 6-25, 7-33, 7-20, 11-22, 12-18.

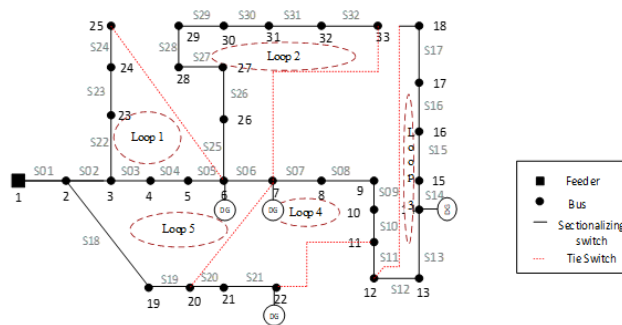

Fig. 20: IEEE\_33 bus system after reconfiguration

After reconfiguration the active power loss(kW) in each bus is given in Table 9.

**Table 9:** Losses after reconfiguration

BusNo.	Before RFG	After RFG	Bus No.	Before RFG	After RFG
1	12.2404	5.2264	17	0.05314	0.24177
2	51.7912	19.3702	18	0.16095	0.16062
3	19.9005	4.42109	19	0.83218	0.83043
4	18.6989	3.70735	20	0.10076	0.10055
5	38.2486	7.17509	21	0.04363	0.04354
6	1.91452	0.19449	22	3.18163	3.13843
7	4.83797	0.14188	23	5.14368	5.07372
8	4.18054	0.01827	24	1.28745	1.26988
9	3.56091	0.08753	25	2.6009	0.76927
10	0.5537	0.0398	26	3.32899	0.94391
11	0.88113	0.12916	27	11.3009	3.08014
12	2.66624	0.85922	28	7.83335	2.08358
13	0.72916	0.48079	29	3.89567	2.03813
14	0.35697	1.0117	30	1.59364	0.2105
15	0.28147	0.05091	31	0.2132	0.00051
16	0.25163	0.22387	32	0.01317	0.11138

**Table 10:** Comparison of TTLOA with other methods in IEEE-33 bus system

Method	Total Power Loss	Power loss after reconfiguration	Loss reduction	% Enhancement
<b>Proposed TLOA</b>	123.5159	38.36	85.15	68.96
<b>TOA</b>	127.935	48.432	79.503	62.14
<b>TLBO</b>	129.9713	48.593	81.37	62.61
<b>PSO</b>	131.34	44.896	86.444	65.81

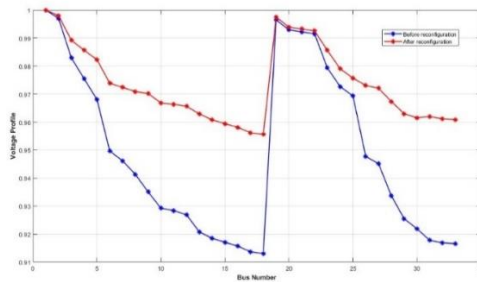

**Fig. 21:** Voltage Profile after reconfiguration

For IEEE<sub>69</sub> bus system the system reconfiguration occurs when a line fault occurs at *line 11*. the optimal tie switch connections through reconfiguration are 11-46, 12-22, 27-69, 35-65, 64-67. The bus system after reconfiguration is shown in Fig. 20. Voltage Profile after reconfiguration are shown in the Fig. 21. Comparison of TTLOA with other methods in IEEE-33 bus system

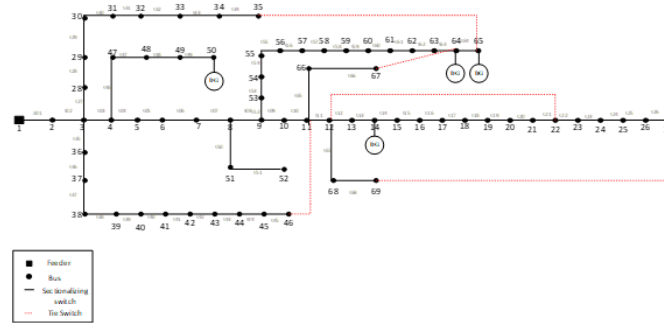

Fig. 22: IEEE\_69 bus system after reconfiguration

The power loss (kW) after reconfiguration is given in Table. 10. IEEE\_69 bus system after reconfiguration is shown in the Fig. 22. Power loss analysis after reconfiguration is shown in the Table 11.

Table 11: Power loss analysis after reconfiguration

Bus No.	Before RFG	After RFG	Bus No.	Before RFG	After RFG	Bus No.	Before RFG	After RFG
1	0.07498	0.05111	24	0.00605	0.00577	47	0.58281	0.58278
2	0.07498	0.05111	25	0.00249	0.00238	48	1.63351	1.63342
3	0.19493	0.12876	26	0.00035	0.00033	49	0.1159	0.11589
4	1.93636	1.10965	27	0.00035	0.00035	50	0.00176	0.00174
5	28.2354	16.1806	28	0.00258	0.00258	51	4.38E-05	4.33E-05
6	29.3431	16.8048	29	0.00583	0.00583	52	5.78124	3.92597
7	6.8933	3.91096	30	0.00103	0.00103	53	6.71142	4.55294
8	3.37439	1.85962	31	0.00514	0.00514	54	9.12469	6.15251
9	4.77283	1.38714	32	0.01229	0.01229	55	8.7901	5.89325
10	1.01379	0.27683	33	0.0104	0.0104	56	49.6845	33.3106
11	2.18925	0.30554	34	0.00048	0.00048	57	24.4892	16.4186
12	1.28427	0.02143	35	0.00141	0.00141	58	9.50568	6.37301
13	1.24544	0.02237	36	0.01508	0.01508	59	10.671	6.97365
14	1.20459	0.02429	37	0.01732	0.01732	60	14.0262	9.16636
15	0.22384	0.00451	38	0.005	0.005	61	0.11205	0.00433
16	0.3204	0.0107	39	0.0002	0.0002	62	0.13493	0.00365
17	0.0026	0.00047	40	0.04871	0.04871	63	0.66117	0.01788
18	0.10412	0.07623	41	0.02012	0.02012	64	0.04121	0.03941
19	0.06693	0.00436	42	0.00266	0.00266	65	0.00262	0.00258
20	0.1074	0.10248	43	0.00051	0.00051	66	1.53E-05	1.51E-05
21	0.00054	0.00051	44	0.00608	0.00608	67	0.02332	0.02282
22	0.00514	0.0049	45	1.26E-05	1.26E-05	68	3.71E-05	3.63E-05
23	0.01119	0.01067	46	0.02329	0.02328			

**Table 12:** Comparison of TTLOA with other methods in IEEE-33 bus system

Method	Total Power Loss	Power loss after reconfiguration	Loss reduction	% Enhancement
<b>Proposed TLOA</b>	173.4724	50.936	122.5364	70.63
<b>TOA</b>	177.2895	54.347	122.9425	69.35
<b>TLBO</b>	180.7287	53.572	127.157	70.35
<b>PSO</b>	183.0419	53.635	129.4069	70.32

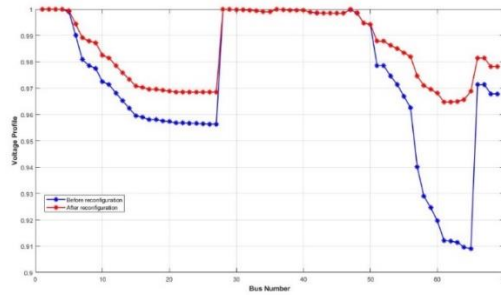

**Fig. 23:** Voltage Profile after reconfiguration

Voltage Profile after reconfiguration are shown in the Fig. 23.

*i. Power loss analysis after reconfiguration*

The fault conditions are, in case 1 fault occurs at bus 22, in case 2 fault occurs at line 11. For case 3 fault occurs simultaneously at bus 22 and line 11. In case 4 the DGs at 22, 25, 33, and 18 are disconnected due to fault. During the fault conditions the system is reconfigured for the optimal performance of the distribution system by achieving the balanced load distribution. After reconfiguration the  $P_{loss}$  in each case for the bus systems are determined and is given in Table 9. Comparison of TTLOA with other methods in IEEE-33 bus system are shown in the Table 12.

**Table 13:** Power loss analysis in bus systems after reconfiguration

$P_{loss}$ (kW)	IEEE 33	IEEE 69	IEEE 119	Indian 52
<b>Case 1</b>	48.0293	129.435	138.393	155.64
<b>Case 2</b>	111.36	133.604	149.32	149.35
<b>Case 3</b>	123.54	136.493	156.07	159.34
<b>Case 4</b>	143.5	140.825	154.64	183.64

After reconfiguration, different power loss values were observed in four different power systems. For the IEEE 33-bus system, the power loss ranged from 48.03 kW in Case 1 to 143.5 kW in Case 4. In the IEEE 69-bus system, the power loss ranged from 129.435 kW in Case 1 to 140.825 kW in Case 4. In the IEEE 119-bus system, the power loss ranged from 138.393 kW in Case 1 to 156.07 kW in Case 3. Finally, in the Indian 52-bus system, the power loss ranged from 149.35 kW in Case 2 to 183.64 kW in Case 4." This paragraph summarizes the power loss values that were observed in different power systems after reconfiguration, with each system having its own range of power loss values across different cases. Power loss analysis in bus systems after reconfiguration are shown in the Table 13.

In case 3 the fault occurs simultaneously at bus 22 and line 11. After reconfiguration the power loss in each bus is given in Table 7.

## v. CONCLUSION

The study has shown that the Hybrid TTLOA model is a promising approach for simultaneous DNR and optimal placement of distributed generators for loss reduction. The model has been tested and validated on multiple test bus systems, under various outage scenarios, demonstrating its robustness and effectiveness in diverse conditions. The implementation of the TTLOA method in MATLAB has resulted in significant reductions in power loss and improvements in voltage profile when four DGs are connected, as well as the optimal placement of distributed generators. A comparison with other existing methods has also confirmed that the proposed model outperforms in terms of reducing  $P_{loss}$  and  $Q_{loss}$  and improving the voltage distribution. Therefore, the Hybrid TTLOA model provides a promising solution for improving the efficiency and reliability of distribution networks.

## ACKNOWLEDGMENTS

The authors would like to thank the Deanship of Annamalai university, Annamalai nagar, for supporting this work.

## REFERENCES

- [1] A.O. Salau, Y.W. Gebru, D. Bitew, 2020. Optimal network reconfiguration for power loss minimization and voltage profile enhancement in distribution systems. *Heliyon*, 6(6), p.e04233.
- [2] de Oliveira, L.W., Carneiro Jr, S., De Oliveira, E.J., Pereira, J.L.R., Silva Jr, I.C. and Costa, J.S., 2010. Optimal reconfiguration and capacitor allocation in radial distribution systems for energy losses minimization. *International Journal of Electrical Power & Energy Systems*, 32(8), pp.840-848.
- [3] Essallah, S. and Khedher, A., 2020. Optimization of distribution system operation by network reconfiguration and DG integration using MPSO algorithm. *Renewable Energy Focus*, 34, pp.37-46.
- [4] Fathi, R., Tousi, B. and Galvani, S., 2023. Allocation of renewable resources with radial distribution network reconfiguration using improved salp swarm algorithm. *Applied Soft Computing*, 132, p.109828.
- [5] Gebru, Y., Bitew, D., Aberie, H. and Gizaw, K., 2021. Performance enhancement of radial distribution system using simultaneous network reconfiguration and switched capacitor bank placement. *Cogent Engineering*, 8(1), p.1897929.
- [6] Hota, A.P. and Mishra, S., 2020. Loss allocation in distribution networks with distributed generators undergoing network reconfiguration. *International Journal of Electrical and Computer Engineering*, 10(4), pp.3375-3383.
- [7] Hota, A.P., Mishra, S. and Mishra, D.P., 2022. Active power loss allocation in radial distribution networks with different load models and DGs. *Electric Power Systems Research*, 205, p.107764.
- [8] Huy, T.H.B., Van Tran, T., Vo, D.N. and Nguyen, H.T.T., 2022. An improved metaheuristic method for simultaneous network reconfiguration and distributed generation allocation. *Alexandria Engineering Journal*, 61(10), pp.8069-8088.
- [9] Jafar-Nowdeh, M. Babanezhad, S. Arabi-Nowdeh, A. Naderipour, H. Kamyab, Z. Abdul-Malek, and V.K. Ramachandaramurthy, 2020. Meta-heuristic matrix moth-flame algorithm for optimal reconfiguration of distribution networks and placement of solar and wind renewable sources considering reliability. *Environmental Technology & Innovation*, 20, p.101118.
- [10] Lotfi, H., 2022. Multi-objective network reconfiguration and allocation of capacitor units in radial distribution system using an enhanced artificial bee colony optimization. *Electric Power Components and Systems*, 49(13-14), pp.1130-1142.
- [11] Lotfi, H., Azizivahed, A., Shojaei, A.A., Seyedi, S. and Othman, M.F.B., 2022. Multi-objective Distribution Feeder Reconfiguration Along with Optimal Sizing of Capacitors and Distributed Generators Regarding Network Voltage Security. *Electric Power Components and Systems*, 49(6-7), pp.652-668.
- [12] Merzoug, Y., Abdelkrim, B. and Larbi, B., 2020. Distribution network reconfiguration for loss reduction using PSO method. *International Journal of Electrical and Computer Engineering*, 10(5), p.5009.
- [13] Nawaz, S., Imran, M., Sharma, A. and Jain, A., 2016. Optimal feeder reconfiguration and DG placement in distribution network. *International Journal of Applied Engineering Research*, 11(7), pp.4878-4885.
- [14] Nawaz, S., Singh, S. and Awasthi, S., 2018. Power Loss Minimization in Radial Distribution System using Network Reconfiguration and Multiple DG Units. *European Journal of Scientific Research*, 148(4), pp.474-483.
- [15] Neda, O.M., 2020. A new hybrid algorithm for solving distribution network reconfiguration under different load conditions. *Indonesian Journal of Electrical Engineering and Computer Science*, 20(3), pp.1118-1127.
- [16] Olamaei, J., Niknam, T. and Arefi, S.B., 2012. Distribution feeder reconfiguration for loss minimization based on modified honey bee mating optimization algorithm. *Energy Procedia*, 14, pp.304-311.
- [17] Pathan, M.I., Al-Muhaini, M. and Djokic, S.Z., 2020. Optimal reconfiguration and supply restoration of distribution networks with hybrid microgrids. *Electric Power Systems Research*, 187, p.106458.

- [18] Pegado, R., Ñaupari, Z., Molina, Y. and Castillo, C., 2019. Radial distribution network reconfiguration for power losses reduction based on improved selective BPSO. *Electric Power Systems Research*, 169, pp.206-213.
- [19] Raposo, A.A., Rodrigues, A.B. and da Silva, M.D.G., 2020. Robust meter placement for state estimation considering distribution network reconfiguration for annual energy loss reduction. *Electric Power Systems Research*, 182, p.106233.
- [20] S. Sivanagaraju, T. Ramana, 2004. A simple method for feeder reconfiguration and service restoration of distribution networks. *Electric power components and systems*, 32(9), pp.883-892.
- [21] S.Ganesh, R.Kanimozhi, 2018. Meta-heuristic technique for network reconfiguration in distribution system with photovoltaic and D-STATCOM. *IET Generation, Transmission & Distribution*, 12(20), pp.4524-4535.
- [22] Saffar, A., Hooshmand, R. and Khodabakhshian, A., 2011. A new fuzzy optimal reconfiguration of distribution systems for loss reduction and load balancing using ant colony search-based algorithm. *Applied Soft Computing*, 11(5), pp.4021-4028.
- [23] Shi, Q., Li, F., Olama, M., Dong, J., Xue, Y., Starke, M., Winstead, C. and Kuruganti, T., 2021. Network reconfiguration and distributed energy resource scheduling for improved distribution system resilience. *International Journal of Electrical Power & Energy Systems*, 124, p.106355.
- [24] V.K. Thunuguntla, S.K.Injeti, 2022. Butterfly optimizer assisted Max–Min based multi-objective approach for optimal connection of DGs and optimal network reconfiguration of distribution networks. *Journal of Electrical Systems and Information Technology*, 9(1), p.8.
- [25] Zidan, A. and El-Saadany, E.F., 2013. Distribution system reconfiguration for energy loss reduction considering the variability of load and local renewable generation. *Energy*, 59, pp.698-707.