

<sup>1</sup> Sandeep  
Bishla\*<sup>2</sup> Dr. Anita  
Khosla

## A Survey of Fast Charging Systems in Electrical Vehicles using Solar and Grid Sources



**Abstract:** - Electric vehicles (EVs) offer green mobility, however, the market for electric cars experiences very low annual growth due to a need for EV charging stations, a drawn-out charging process, and grid variability during periods of high demand. The automotive industry strives to offer clean and adequate fuel-based transportation, and EVs are the best alternatives to conventional Integrated Circuit (IC) engine-based automobiles. Fast charging of EVs is necessary to overcome the main obstacle to EV adoption, which is the length of the charging process. Various solutions have been put forth with the adoption and absorption of fast public charging. With the development of EVs, there is a rising need for charging stations. In the charging station, a many power is needed. The energy required is significantly larger in a Fast Charging Station (FCS). Power loss, Voltage instability, harmonic distortion, and transformer overloading are all effects of the unexpectedly increased demand for electricity in the distribution system. So in this survey, fast charging techniques with two sources, such as grid and solar, were analyzed and discussed. This review paper aims to address a major challenge hindering the widespread adoption of electric vehicles (EVs) - the time-consuming charging process. The article focuses on fast charging techniques using grid and solar power sources. As the demand for EVs increases, the need for charging stations also grows, including the power requirements of Fast Charging Stations (FCS). The paper analyzes and discusses the techniques used in FCS and the pros and cons of utilizing grid and solar power sources. The primary contribution of this work is to assess rapid charging systems that use both solar and grid references, identifying the challenges and issues associated with current EVs. The paper concludes that the development of fast charging systems that incorporate both grid and solar power sources is essential to promote the widespread adoption of EVs and offers a promising solution to the challenges facing the transition to a sustainable transportation system.

**Keywords:** Fast Charging System, Electric Vehicles, Grid Source, Solar Source, SPV, Renewable Energy Sources, Photovoltaic, Power Consumption.

### 1. INTRODUCTION

Traditional Internal Combustion Engine (ICE) vehicles are gradually being replaced due to developments in the electric vehicle (EV) sector. These EVs are cleaner, more energy-efficient, and require less upkeep than traditional ICE vehicles [1,2]. Most current charging infrastructures depend on the utility grid, which still uses fossil fuels to produce energy and can indirectly contribute to pollution [3]. One method to reduce this pollution is to combine charging design with Renewable Energy Sources (RES), reducing the need for the utility grid. EV charging still faces challenges like poor battery performance influenced by charger characteristics [4, 5]. One of the biggest challenges for EVs is their long charge periods; however, these can be reduced by including better conversion schemes in the fast-charging network [6]. Isolated transformers must be utilized to establish a wall between the user end and the high-voltage network while creating an EV charger. RES can be used by electric vehicle charging stations (EVCS) [7]. Examples of RES include wind and solar energy systems. Energy systems based on wind and photovoltaic (PV) energy are far more efficient and straightforward. EVCS off-grid with Energy Storage Systems (ESS) backup is now accessible in remote locations without connection to the utility grid [8, 9]. The power needs of remote charging stations can be calculated to estimate the size of the backup ESS. Many adaptive methods are being developed to optimize energy storage [10, 11]. If a grid is present, energy PV systems are preferable over freestanding ones; however, RES are erratic [12]. Grid-connected Photovoltaic systems are preferable over standalone systems where a grid is present, however, RES is irregular [13, 14]. Depending on the requirements, these designs may or may not be isolated [15,16].

The right converter architecture must be utilized to charge EVs; it must be very effective and, ideally, have low switching losses [17]. Generally, isolated converters achieve high voltage gain, but since they require large inductors, modified non-isolated converters can be used in their place [18]. A grid-connected PV system's main objective is to reduce grid demand while utilizing the grid as a backup if the solar system fails. Reduced maximum voltage gain, stress, low voltage THD, and low output current are advantageous characteristics for an inverter between PV and the grid [19, 20]. Due to their lower fuel emissions, EV technology is gaining popularity, and their numbers are anticipated to increase quickly [21]. This necessitates continued development of their charging arrangements, particularly for rapid charging systems intended for public and commercial applications and operating similarly to gas stations [22]. The problems of range concern and charging times, two

<sup>1\*,2</sup> Faculty of Engineering & Technology, Manav Rachna International Institute of Research & Studies (MRIIRS), Faridabad, Haryana, India

Corresponding Author's Mail: sandeep@bishla.in

Copyright © JES 2024 on-line: journal.esrgroups.org

of the main barriers to general EV adoption, can be solved using FCS [23]. The short-distance installation of these practical and durable fast-charging stations would give an unconstrained range for EVs [24].

There are many benefits to attaching EVs to the electrical grid, such as reactive energy support, associated services, and bandwidth allocation. Still, there are drawbacks, such as problems with power quality, infrastructure building, network loading, etc. [25, 26]. The technological difficulties in integrating EV charging facilities by the grid are explored [27]. Unplanned or haphazard EV charging can lead to voltage fluctuations, distribution scheme losses, and subpar power quality. Other problems include the instability issue and the shortening of transformer life due to overloading [28]. To reduce these effects, ESS and incorporating RES with the charging systems are just two demand-side management tactics [29]. We look at the benefits of installing energy storage devices to lessen the load on the grid caused by EV charging. With a focus on solar PV, RES and an alternative source for EV charging are investigated. To support the grid, the notion of "vehicle-to-grid" (V2G) power flow is emerging [30, 31]. Planning a charging station is a difficult task. It considers variables such as the availability of RES, the unpredictable nature of traffic demands, the complexity of the site's architecture, and other factors that may affect the organization of hourly power [32]. So, to create a planning framework for a charging station, it is necessary to link short-term operation results with long-term planning results [33, 34]. In addition, the data's accessibility gives designers of FCS access to information about EVs on transportation networks, such as real-time charging and historical data. The gathered data support a cutting-edge, data-driven pattern [35].

The review on fast charging systems in electric vehicles (EVs) that utilize both solar and grid power sources addresses several critical problems and challenges that impede the widespread adoption of EVs. One of the primary challenges is the time-consuming charging process that often discourages people from choosing EVs as a viable mode of transportation [87]. The review also highlights the power requirements of fast charging stations and the adverse effects that sudden increases in demand can have on the distribution system. Furthermore, the study discusses the obstacles to integrating solar and grid power sources into fast charging systems, such as the need for advanced power electronics and control systems to manage the electricity flow [88]. However, the review's primary contribution is its comprehensive analysis and evaluation of fast charging systems that use solar and grid power sources, identifying the issues and challenges existing EVs face. The review also provides a detailed discussion of the advantages and disadvantages of fast charging systems that use solar and grid power sources, offering valuable insights into their potential to overcome the obstacles to widespread EV adoption. By addressing these challenges and identifying potential solutions, this review provides a valuable resource for researchers, policymakers, and industry practitioners working towards a more sustainable transportation system [89, 90].

This paper discusses various aspects of the FCS for EVs, such as the international standards created for EV charging, the charging station topology, the difficulties and obstacles encountered during implementation, and various strategies to overcome those difficulties.

This survey investigates the landscape of fast charging systems in electric vehicles, emphasizing their integration with both solar and grid sources. The study aims to analyze existing technologies, assess the viability of solar-powered fast charging, and explore grid-based solutions. Its objective is to provide insights into the evolving dynamics and potential synergies between solar and grid sources in enhancing electric vehicle charging infrastructure.

The survey aims to thoroughly examine and compare fast charging systems designed for electric vehicles (EVs) that leverage both solar and grid power sources. This research seeks to assess the technological progress, effectiveness, and sustainability of these charging solutions, offering insights into their environmental implications, economic viability, and overall operational efficiency. Through the evaluation of the integration of solar and grid power, the survey strives to provide original insights that can inform the development and enhancement of upcoming EV charging infrastructure. The ultimate goal is to contribute to the creation of a more sustainable and efficient transportation ecosystem.

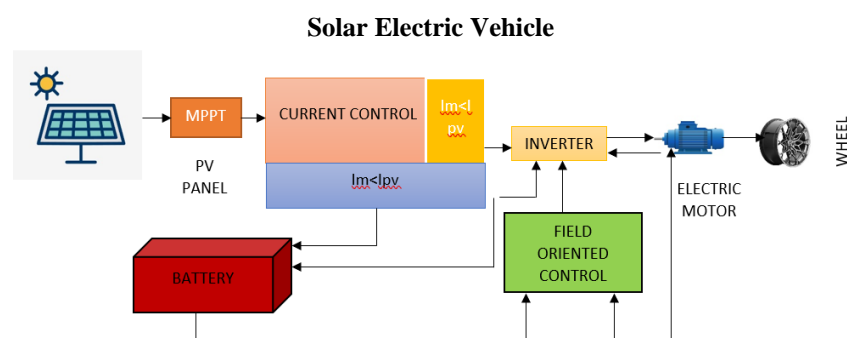

**Figure:1**

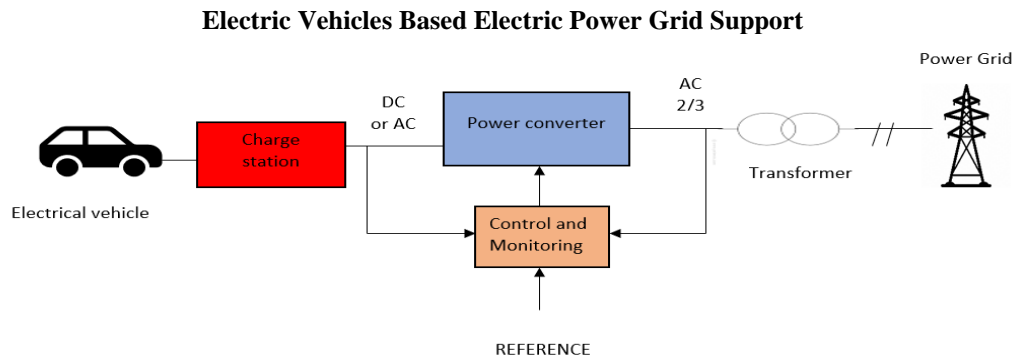

## 2. RELATED WORKS

This section describes the numerous techniques designed in a fast charging system using grid and solar sources. Also details the existing techniques' advantages, disadvantages, merits, demerits, years, and so on.

### 2.1 Fast charging system in the electric vehicle using solar sources

The demand for various climate change and low-pollution energy sources has increased due to transportation. However, charging EVs through the grid will become increasingly challenging as extra EVs enter the road. Consequently, an effective FCS for EVs that use RES is needed. Furthermore, although solar energy is renewable and environmentally friendly, its unpredictable nature and the need for dynamic EV charging have created new challenges for efficient EV charging from these sources. Niharika et al. [36] examine using a DC level 1 fast charger with a Phase-Shifted Full Bridge Converter (PSFBC) as the primary charging system that delivers a 50 KW load to EVs. The suggested system also develops a fuzzy controller to maintain a consistent voltage at the output of boost converters linked to solar panels

Energy consumption has increased as a result of urbanization and population growth. Since the vast majority of energy comes from sources that rely on fossil fuels, they have harmed the environment. Hybrid EVs were created as a result of environmental protection efforts. Elements including cost, battery technology, economics, and the creation of quick charging infrastructure influence market adoption of EVs. FCS significantly influences the penetration of the EV market. This study's main topic is the Goswami et al. [37] design of a PV-hybrid FCS. A load of Solar Power Plant (SPP) is 100 kW that, including storage, is part of the charging station that minimizes reliance on grid electricity and boosts profitability. Maximum Power Point Tracking (MPPT) control employs the Stochastic Firefly Algorithm (SFA) to get the most power out of the SPP and ensure quick charge of the station batteries. When demand is low, the station will draw power from the batteries; when demand is high, it will draw power from the grid. To reduce investment costs and boost charging station profits, the study also proposes a multi-objective planning strategy using SFA. Results indicate that employing SFA makes it possible for batteries to be charged rapidly and boosts charging stations' profitability.

Paula et al. [38] designed Hybrid Renewable Energy Systems (HRES) with EVCS; the research offers a novel multicriteria methodology. The process includes an experimental phase for the power balance and SOC. Valencia (Spain) 's environmental policies are why it was selected as a case study. The ideal setup is the off-grid-based HRES combining batteries, wind resources, and solar PV. Fast EVCS must be installed to increase the acceptance of EVs by their users. Nonetheless, if the grid only powers EVCS, adverse effects on their stability and potential increases in CO<sub>2</sub> emissions may result. By lessening the demand on the grid and producing clean electricity, the development of HRES for EVCS can address both problems. The most appropriate HRES configuration for EVCS is designed using a weighted multi-criteria process developed in this study. First, the localized RES and EVCS electricity needs are determined. Then, based on technical, economic, and environmental considerations, it determines the power generation of the best HRES strategy for EVCS. Finally, a new phase is added to verify the developed model derived from the multicriteria approach. As a result, the developed model's last power generation design is accompanied by an experimental analysis of the demand being completely met and a thorough numerical evaluation.

To optimize net profit, this work provides a specific design problem of fast EVCS. The recharging station is connected to RES and Battery Electricity Storage Systems (BESS) to lower the grid's energy demand. Ray et al. [39] suggested algorithm estimates the design problem's performance indices, including the quantity and quality of chargers, RES installed power, energy and electricity from storage units, and dynamic grid power delivered to the electric vehicle charging station. The sequential Monte Carlo method is used to simulate the best-adapted charging cycle. The hybrid Crow Search Algorithm and Particle Swarm Optimization (hCSA-PSO) is used for the first time to reduce the installation and maintenance costs of the charging station. They are evaluating the

suggested approach's performance compared to CSA, PSO, and a new hybrid pattern search algorithm. Numerous case studies show that hCSA-PSO produces the most profit-maximizing results when considered. Finally, the economic feasibility of RES and BESS is evaluated using the cost-benefit analysis.

The introduction of fast-charging electric car charging stations is essential for the electric vehicle (EV) industry to succeed in EVCS. Both potential and concerns exist when using clean energy in EV charging stations. Having a setup with a feasible and sufficient capacity and proper EVCS planning is advantageous and essential. Kumar et al. [40] proposed the joint deployment of solar PV, BESS, and rapid charging EVCS by dynamic charge and discharge under linked distribution and transportation networks is proposed as a two-stage sustainable framework. The numerical results show the various advantages of the proposed architecture, including a reduction in active power losses, network power consumption, and voltage deviations just at the point of common coupling (PCC), which may occur due to rising EV charging demand.

Sabarimuthu et al. [41] present a Battery Charging Circuit (BCC) that charges light electric vehicles with grid and solar electricity. The suggested method creates a hybrid charger with a control system to assess the electric car batteries using the dual input power. The additional car and the electrically operated vehicle receive electricity from this hybrid charging arrangement. The utilized system model determined battery state estimation, and the model's accuracy impacts state estimate accuracy. The microprocessor performs the role of an intelligent charger by managing the voltage and current requirements for battery charging. Additionally, the proposed work shows the performance level of rechargeable batteries and voltage variations in a battery simulator throughout phase 1 to phase 2 required to charge levels, current variants during phase 1 to phase 2 and phase 2 to phase 3 charging stations, and all these variations are shown through experimental and simulation data. A comparison was made between the typical power usage of a traditional charger and a suggested charger both during the day and at night. A charging station's energy requirements, the likelihood of storage capacity, the effects of charging and discharging the battery, and the battery's charging ability and temperature are all studied further with the suggested system. The comparison of the results shows that the proposed strategy outperforms the already-used approaches.

Hybrid electric vehicles (HEV) have grown tremendously in the past few years, from their creation to the charging methods. Rapid charging, V2G, G2V, hybrid required to charge topologies, and other operations are only a few of the operations that have emerged due to the advancement of EV technology. With an innovative Modified Z-Source Inverter, we are now concentrating on quickly charging EVs utilizing RES like solar energy, which offers great efficiency and cuts down on charging time (MZSI). The reliability of the base load charging system will decline with the integration of RES like solar. Additionally, we can connect the power converter with the battery and charger thanks to this converter. The DC-DC conversion in this architecture powers the charging system. The charger topology described by Ramanathan et al. [42] features separate modes of operation. The design, simulation, and functioning of an electric vehicle fast charging that uses a modified Z-source inverter built into a PV-Grid-connected system are covered in this work.

EV use has increased significantly in recent years across the globe. Due to the controlled consumption decrease those using EVs enables, this contemporary transport mode is observed as environmentally beneficial. However, these charging infrastructures could harm the distribution system and the ecology, increasing peak load. Employing independent energy sources, such as solar energy, is a feasible and effective way to lessen the harmful consequences of fossil fuels. Given that more Vehicles will be linked to the grid, this strategy should allow for adequate distribution system design to fulfill load demand. Eltoumi et al. [43] list, present, and analyze PV-EV stances and Architectures for PV-EV-Grid hybrid charging systems and their associated control structures, as well as various points of view and problems a challenge to EV charging technologies, are also discussed. This is a result of the subject's growing importance. A study of the various EV charging scheduling techniques and control topologies given in the literature is also covered, as well as the impacts of many EVs connected to the grid. Finally, research suggestions and prospects for future studies are discussed regarding the financial benefit assessment of the power grid and EV load. Table 1 gives an overview of the solar-powered fast charging system.

**Table.1 Summary of fast charging system using solar sources**

Author	Year	Techniques	Advantages	Disadvantages
Niharika et.al [36]	2021	Fuzzy controller method	<ul style="list-style-type: none"> <li>● It allows for the use of RES for charging.</li> <li>● Management is free</li> </ul>	<ul style="list-style-type: none"> <li>● The direct charging method is the inadequacy and irregularity of PV electricity to charge an EV continuously.</li> </ul>
Goswami et.al [37]	2021	Firefly method	<ul style="list-style-type: none"> <li>● It controls charging.</li> <li>● It promotes the use of charging during advantageous times.</li> </ul>	<ul style="list-style-type: none"> <li>● No energy costs</li> <li>● High energy consumption</li> </ul>

Bastida-Molina et.al [38]	2021	Power generation method	<ul style="list-style-type: none"> <li>● It permits providers to manage to charge to suit grid needs remotely.</li> <li>● Charges are switched when the system produces more renewable energy than is needed.</li> </ul>	<ul style="list-style-type: none"> <li>● Electricity storage is a very high cost</li> <li>● Indirect pollution cause</li> </ul>
Ray et.al [39]	2021	Swarm intelligence method	<ul style="list-style-type: none"> <li>● Avoiding peak hours</li> <li>● PV grid charging</li> </ul>	<ul style="list-style-type: none"> <li>● Low torque</li> <li>● Low acceleration</li> </ul>
Kumar et.al [40]	2021	Queueing and genetic algorithm method	<ul style="list-style-type: none"> <li>● It has no vibration</li> <li>● Compared to a gasoline car, there are no odors, noises, or difficult gear changes.</li> </ul>	<ul style="list-style-type: none"> <li>● Overload batteries</li> <li>● Range anxiety</li> </ul>
Sabarimuthu et.al [41]	2021	Fast and hybrid charger	<ul style="list-style-type: none"> <li>● It is convenient</li> <li>● Better battery</li> </ul>	<ul style="list-style-type: none"> <li>● Charging the battery is taken more time</li> </ul>
Ramanathan et.al [42]	2022	Modification of z-source inverter	<ul style="list-style-type: none"> <li>● Acceleration is good</li> <li>● Electricity consumption is less</li> </ul>	<ul style="list-style-type: none"> <li>● High maintenance</li> <li>● High electricity consumption</li> </ul>
Eltoumi et.al [43]	2021	Techno-economic method	<ul style="list-style-type: none"> <li>● Efficient is high</li> <li>● The performance is high</li> </ul>	<ul style="list-style-type: none"> <li>● Lacks the power</li> <li>● Less efficient.</li> </ul>

To lessen the effect of greenhouse gases, the electric vehicle market has recently experienced tremendous growth. For successful implementation, using modern control algorithms and cost-effective, optimal EVCS akin to those found at gas and diesel stations is necessary. A review of EVs and different charging station setups is given by Narasipuram et al. [44]. To reach an ideal design, various optimization techniques, approaches, and directions for the future are offered, and the charging points are categorized according to the quantity of electricity utilized. The key features of grid-connected, off-grid, and renewable energy-based modes and the future scope are outlined. By summarizing these essential topics, the review study seeks to give researchers and industry specialists a detailed understanding of potential future advancements.

Due to the expansion of green tech in transportation, EVs must be an essential choice for reducing greenhouse gas emissions. Another off-EV charging station can dramatically expand EV use in rural locations. Renewable radiation is the ideal option because of its availability and simplicity of installation. Solar energy fluctuates throughout 24 hours; hence an Energy Storage Unit (ESU) is also necessary for addition to a PV array. In Krishnan et al. [45] efficient design method, a rapid station with a maximum PowerPoint slide tracking boost converter, a bidirectional DC-DC converter with a shunt resistor circuit, and an ESU is employed. On either hand, ESU uses solar energy that is produced in excess to create an ideal system for managing power. As a result, an eco-friendly, dependable, and effective off-grid EV battery charger is produced. MATLAB is used for validating the suggested method and assessing system performance.

Due to its ability to provide power to consumers without disrupting the energy market, RES has become a well-known landmark on a worldwide scale. The application of RES in EVCS is one of the largest areas of research conducted in developing countries. The ecological, technological, and financial implications of the hybrid solar-wind automotive charging stations along a roadway in Southern Tamil Nadu, India, are examined by Nishanthy et al. [46]. Virudhunagar's achievement of the proposed planned system shows a reduced net present value of \$303 291.26 and a cost of energy of \$0.072/kWh with such a 50% emission reduction. It can charge 17 EVs all day, from sunrise until night, from 6:00 AM to 6:00 AM. Additionally, Madurai produces 70% more electricity compared to the other areas, per economic research. The system's performance analysis is also examined because it creates more relevant and accurate results when considering financial and technical research.

The usage of EVs and Electric Railway Power Systems (ERPS) as a load in reduced transportation is growing in popularity globally. PV modules and wind turbines are employed as RES to completely or partially supply the demands in addition to the main utility grid. Specialized DC-DC electronic power converters built into chargers process the electricity consumed by the chargers and the power produced by renewable resources. A disk array is also employed as a backup system due to the intermittency of RES and its inability to power the loads continually. This holds in all circumstances, not just blackouts. The power management system (PMS) described by Ahmadi et al. [47] regulates the power flow from a wind generator to a Peripheral device and the proper power regulation for various components. The suggested technique was tested on a solid 3 kV high-speed line between Rome and Florence in Italy using factual information on the ERPS load.

To meet the needs of Plug-in Electric Vehicle (PEV) charging, this work offers a new paradigm for evaluating solar PV forms of energy in a distribution system. Assalam et al. [48] recommended factoring in the driver's temporal-spatial features, irradiance, and temperature to imitate the unpredictability of both PEV needs and PV generation. PV resource penetration rate and the effects of employing various strong empirical evidence are being researched. This research enhances the models provided in the literature by including the temporal-spatial aspects of PEV exorbitant costs in PV stochastic models.

Salkuti et al. [49] EVs and renewable energy resources (RERs) are quickly gaining popularity due to rising oil prices and environmental concerns, and they are crucial to a smooth transition. However, energy storage is the shortcoming of EVs that slows their development. With the help of adequate incentives for EV owners, legislative backing, and incentives for local manufacturers, the global EV industry is advancing toward a faster adoption rate. Internal combustion engines are seeing an actual alternative with the rising demand for EVs. The RERs' primary characteristics are their sporadic and variable nature. Various RES— backup sources and storage units—are incorporated to overcome these restrictions. The cost-benefit analysis of EVs and energy storage systems is covered in this paper, along with several other technologies, issues, and processes.

The transportation sector's increased use of conventional gasoline led to the fuel's quick depletion. The digitalization of the transport industry has thus been the primary research subject over the past ten years. Electric vehicles have quickly replaced internal combustion engines during the past few years. The growth in the number of electric cars on the roads substantially negatively impacted the grid's reliability and the fully electric system. More charging stations must be created to meet the demand for electric vehicles; hence, some corrective measures must be adopted. A complete review of the current EV environment, supercharger network, EV impacts, and best allocation provision for EVs is offered, according to Gupta et al. [50]. This research analyzes the best placement of fast-charging locations based on grid effects and economic benefits. The difficulties with adoption are also explored. On the other hand, prospects in the industry are discussed and outlined, including the use of RES and the advantages of car-to-grid technology. The summaries of the control function in the fast charging system are described in table.2.

**Table.2 summaries of control function in the fast charging system**

Reference	Author	Title	Control Functions
44	Narasipuram et.al	Design factors to take into account while creating electric vehicle charging stations	Frequency control
45	Krishnan Nair et.al	A solitary converter that is bidirectional	Power factor control
46	Nishanth et.al	Hybrid solar and wind-based EV charging stations	Q control
47	Ahmadi et.al	Distributed energy source integration	Power gradient constraint
48	Assolami et.al	A novel method for fast-changing vehicle	Delta production constraint
49	Salkuti et.al	EVs and energy storage	Voltage control
50	Gupta et.al	Allocating electric car supercharger network, policies, and future trends as efficiently as possible	Absolute gradient constraint

## 2.2 Fast charging system in the electric vehicle using grid sources

As a result of technical improvements and environmental concerns, EVs are becoming increasingly popular. However, the demand and charging time are two significant barriers to EV adoption. Elma et al. [51] developed a DC quick charging technique with a dynamic Energy Management System (EMS) to remedy these issues. To shorten the charging time, DC fast chargers need periods of high power demand. The grid will suffer. As a result, problems with the economy, resiliency, and security. The study aims to assess a hybrid DC rapid charging point to lower peak load during charging periods. More trustworthy judgments about the operation of such systems can be drawn when using dynamic data in conjunction with the energy management plan. Its grid's peak usage is drastically reduced by 45% using the suggested control method, and the batteries' lifespan is increased thanks to better start charging coordination.

Prem et al. [52] Although electric vehicles (EVs) provide ecologically friendly transportation, the EV market is only growing each year steadily because of a lack of Electric car charging stations, a drawn-out recharging process, and network instability throughout peak hours. This work proposes a high-gain, quick-charging DC-DC converter, a control algorithm, and an efficient Solar PV-based EVCS (SPV-EVCS) with battery backup. Using the MATLAB/Simulink tool, the effectiveness of the suggested converter is assessed in three different modes, and the simulated results are verified using Real-Time Digital Simulation (RTDS) in OPAL-RT.

The proposed system design and its control structure by Mahfouz et al. [53] are described, developed, and assessed in order to reduce the impact of the host capacitive and inductive on the DC quickly station for EVs. The charging station has batteries for energy storage, limits incoming power according to grid requirements,

and, thanks to its control system, decouples station dynamics from grid dynamics. The charging station can be used to power either the grid or an island. In order to create the Local Controllers, eigenvalue analyses are done on the dynamic models of the charging station both in operating modes (LCs).

The EU's energy paradigm has undergone extensive transformation. For a seamless transition, EVs & RES are essential. Intermittency and the inability of solar and wind energy output to be dispatched are two future issues for the power grid. However, flexibility requirements may move from producing to loading as requirement resources and storage systems advance. Antonio et al. [54] created a unique grid method for the most significant operation of renewable energy sources and electric cars to increase the integration of renewable energy sources. A distributed system that uses V2G technology is given to facilitate miss matched among load and renewable power. Load shedding, peak, and associated services are used to ensure dependable voltage stability, maintain a constant frequency, and flatten the load profile.

The price of the EV, its independence, the charging method, and the charging facilities all impact how popular electric vehicles become (EVs). The development of an EV fast station is this essay's final element and subject. The fast-charging station incorporates renewable electricity (wind and PV) in addition to a storage area to increase fast-charging stations profitability and decrease the strong market for electricity from the grid. Navarro et al. [55] use a holistic framework of the charging period that accounts for the arrival time and energy output of electric vehicles, in contrast to earlier studies. Modeling the demand for EVs and RES is initially done using the Monte Carlo approach. Later, a genetic algorithm improves the EV fast-charging station's setup and utilization (GA). Finally, it selects the optimal choice based on the option's net present value to maximize profit (NPV).

It is crucial to more accurately pinpoint the position and amount of charging stations to increase the penetration and appeal of electric vehicles. Several variables affect the location of charging stations, such as operator economic issues, drivers' satisfaction with their charging, vehicle power outages, transportation system gridlock, and power grid safety. A number of them have been the subject of studies. However, there aren't many systematic studies that consider all of the many aspects. Additionally, current studies are conducted based on statistical information. Dynamic real-time data, which is more rational and scientific than statistical data, is employed for optimal planning more essential. Kong et al. [56] designed a global simulation platform that may be used for the best placement planning across various cities or regions. A real-world situation within Beijing's third ring is investigated. Simulation findings show that the suggested approach may maximize operators' financial interests, improve drivers' happiness with charging, and guarantee grid safety and traffic efficiency.

Retailers and wholesale dealers are interested in using EVs and RES to reduce peak demand. EVs are the challenging domain in SG, with specific interactions between grid and vehicle (V2G) or grid and vehicle (G2V). Future generations of EVs will be developed by integrating renewable energies, making a more significant contribution to the environment and lowering CO2 emissions. Sami et al. [57] show how Smart Buildings (SB) interact with energy storage systems and EVs to shift grid load, reduce peak demand, and lower yearly energy consumption. In addition, to describe important factors affecting the grid-interface network, we created simulation models for V2G and G2V. Several controller factors that influenced the control, stability and dynamics of the energy V2G and G2V systems were evaluated in this case study.

A network of information-equipped charging stations (CSs), cleverly distributed energy-producing units, and supportive public policies are necessary to transition to electric vehicles. Mastoi et al. [58] elaborate on the main considerations for designing the infrastructure for electric vehicle charging (EVC). To enhance the planning and implementation of the infrastructure for charging stations, this document offers information on planning and technology advancements. The current electric vehicle scenario is thoroughly examined, along with the effects of EVs on grid integration and provisioning for EV optimum allocation. This study specifically looks at measures to standardize the infrastructure to facilitate future research and infrastructure research advancements, challenges, and projects. The summary of the fast charging system using grid sources is described in table.3.

**Table.3 summaries of fast charging system using grid sources**

Year	Author	Title	Findings	Applications
2020	Elma et.al [51]	A flexible charging method for EVs using a hybrid fast charging station	Lacks information on the network's electrical behavior during charging, making these models crucial when used with an electrical grid.	Vehicle-to-grid reduces unforeseen expenses associated with constructing an energy system and helps balance electricity demand.
2020	Prem et.al [52]	Solar PV battery and integrated electrical grid FCS and control model for EVs charging station	The model can reduce the worst-case scenario at a low cost relative to the standard objective rate	Demand Response

2019	Mahfouz et.al [53]	Integration of DC rapid charging station for EVs	By offering waiting areas, EVs can help identify where charging stations should be located. In addition to waiting areas, this boosts charger utilization and reduces the need for chargers at each location.	Management of grid
2019	Colmenar-Santos et.al [54]	European Union's 2050 low-carbon scenario calls for an electric vehicle charging system that supports RES.	The technique just examined the empirical probability distribution and disregarded the real one.	Good infrastructure
2019	Navarro et.al [55]	Design FCS in EVs using RES and energy storage technologies	Output power is high, and charging speed is high	Distributed energy sources
2019	Kong et.al [56]	location of the optimal planning method	Due to a lack of thorough cluster analysis in the charging network, high-dimensional datasets were not accessible.	Wider area
2019	Sami et.al [57]	Operation of modes of the electric vehicle with a bidirectional method	Lithium plating occurs in cold climates when lithium deposits build around the battery's anode during charging and reduces battery life and safety, is known to occur with fast charging for electric vehicles.	Awareness of electric vehicle
2022	Mastoi et.al [58]	Infrastructure, policy, and trends of the future for the electric vehicle charging system.	The analysis indicates that random charging causes the burden on the power grid to increase by 10% annually. In comparison, clever scheduling of the EVs (without RES) can fix the issue at the cost of 1.7% more daily cost and 3% more emissions.	More storage space

The automobile industry has developed an effective fuel-based transportation model for the growing air pollution problem. EVs are the best replacements for traditional IC engine-based EVs. The FCS of EVs is necessary to overcome the main obstacle preventing their mainstream adoption: charging time. Various solutions have been put forth for the arrangement and combination of public FCS, particularly assessing load control methods and power quality considerations. Khan, et al [59] proposed a grid-connected model of a fast EVCS that ensures reliable power transfer and low harmonic currents. The power flow from the AC grid to the DC bus is moved differently, and personal vehicle charging steps are decentralized. To decrease the effect of FCS on the grid, an EMS based on the optimal flow of electricity is proposed, which includes combining a solar PV generation system with a charging station. It also improves the power output of the EV fleet batteries in the charging station.

Wang et al. [60] suggested virtual-battery-based droop control system takes battery attributes into account. The proposed coordinated control technique for bus signaling is decentralized. Using data from the real world, a comparable bus capacitance-based model is created. Energy storage system SOC balance and advanced power dispatch are accomplished. The proposed control approach leads to size optimization. Using a DC microgrid is a practical method to reduce the damage that the FCS of EVs does to the electrical grid and boost the accessibility of PV power. In this study, a better decentralized virtual-battery droop management developed with the ability of load power dispatching, bus voltage conservation, and SOC of the Energy Storage System (ESS) is provided to confirm the autonomous and dependable functioning of the DC microgrid. The central Bus-Signalling control is employed to implement analysis and management among PV-ESS-Grid integrated systems. The effectiveness of the proposed control technique is demonstrated in the MATLAB tool using a similar bus inductors model.

The availability of quick charging stations is one factor in the famous attraction of EVs that helps to allay range concerns. Due to the frequency of these parking areas in all metropolitan and residential locations, Hassan et al. [61] build an equal amount of FCS, every able to handle a small amount of FCS in EVs. Moreover, a 3-stage



scheduling scheme based on MPC and stochastic software design is designed for joint task scheduling tasks in slow-charged, fast-charged vehicles and rigid loads. By supplying energy to EVs of various voltage classes, the suggested model can be regarded as a unified strategy for avoiding or at least reducing the need for numerous FCS in urban areas. Exhaustive examples show how the proposed method effectively manages the charging load of several EV types.

Drobnic et al. [62] developed an off-board-based DCEVs rapid battery system to deliver Ripple-Free Output Current (RFOC) in standard EV batteries. The three typical two-level three-phase converter modules that make up the ac/dc interleaved active rectifier can significantly alter the voltage level of the DC link to eliminate the ripple of output current. The interface between the battery and DC link is a modular interleaved DC/DC converter made up of identical 3-phase converter modules linked in parallel. The maintenance and capital costs of high-power FCS in EVs can be decreased by utilizing affordable, well-known, and industry-standard 3-phase power modules. Additionally, considering both direct and inverse coupling as viable coupling implementations, the coupling effect on the various input and output current ripples and inductors was investigated. The feasibility and efficiency of the FCS in an EV system eliminate the output of recent waves, which are confirmed by numerical simulations. A scaled-down prototype of the output phase provides experimental findings for checking the ability to operate the output current without ripples.

If the batteries are charged with clean RES, EVs can run completely emission-free, significantly reducing their environmental impact. With the help of other distributed energy storage technologies and EVs, an intelligent microgrid can lessen the effects of power outages and improve electricity quality by supplying electricity in EVs during peak hours. A Multi-Port Isolated Hybrid Converter (MPIHC) is essential for balancing the energy and regulating power flows between the EVs, grid, and RES. A novel MPIHC that has the ability to control power flow in multiple directions is proposed by Khan, et al. [63]. The outcomes, modeling, and execution are all clearly addressed.

The level of electrification in the transportation industry is rising steadily. Along with more established EVs like trains, the number of battery-powered full-electric buses is also growing. Additionally, as electric cars become more popular, their percentage in traffic is steadily increasing. Moreover, large-scale regular and FCS are established to speed up personal and public transportation electrification. Stieneker et al. [64] propose strategies to ensure proper integration into the current electrical grids. Moreover, Medium-Voltage DC (MVDC) distribution grid power supply is described, which reduces the expenses for lost energy and components.

Quddus et al. [65] suggest a stochastic two-stage-based linear programming technique with several periods. The flow rate effects and power demand unpredictability on system routine are investigated. Our computational studies serve as the foundation for several managerial insights. This study suggests a unique formulation for constructing and managing EVCS using a stochastic power demand and predetermined planning horizon that considers short- and long-term operational decisions. It also provides a hybrid approach by combining Sample Average Approximation (SAA) and enhanced Progressive Hedging (PH) optimization to resolve this difficult problem. Results show that when energy costs are low, and SPP is unavailable, the grid and vehicle-to-grid are used predominantly to meet the power demand of electric vehicles.

Despite several initiatives to provide an extensive and practical network of Direct Current Fast Charging (DCFC) stations for EVs. The adoption and use of EVs may need to be improved by this knowledge gap, making it more difficult to plan and invest in the best locations for charging stations. Based on more than 7500 industrial and commercial power tariffs obtainable for 2017, evaluate the energy cost for various situations of DCFC station size. Muratori et al. [66] suggested DCFC-based stations for high levels of unpredictability in use, and the results demonstrate the power cost in DCFC fluctuates. Low utilization, which is caused by the arrangement of infrequent charging measures and small energy revitalization at each one, is the primary cost driver. When compared to rates without demand charges, choosing rates by demand responsibilities can save the cost of electricity for stations with high usage. Additionally, based on current rates, there are considerable opportunities for cost savings, such as preferential charging during off-peak hours and restricting the power of multi-plug stations so that not all plugs can be utilized at full power simultaneously.

Sayed et al [67] planned an EMS and control mechanism for the supply of DC microgrid in FCS of EV is introduced. The studied DC microgrid includes a solar PV array and wind turbine (WT) to cut emissions from carbon pollution and supplement power produced from fossil fuels. Therefore, the solar PV panel, WT, and battery system capabilities need improvement. The RES is tuned to give enough electricity to the EV charging station. Additionally, many RES technologies are being researched to provide EV charging stations and enhance efficiency. Simulated operations are achieved using the MATLAB tool that evaluates the effectiveness of the designed technique. Table.4 describes the benefits and drawbacks of the grid-based FCS.

**Table.4 benefits and drawbacks of the grid-based FCS**

Author	Reference	Year	Title	Merits	Demerits
Khan et.al	<u>59</u>	2019	Exchange of power quality and ensuring optimal is good	Fast charging	The direct charging method requires more practicality of PV electricity to charge an EV continuously.
Wang et.al	<u>60</u>	2019	The storage system of energy and droop control of virtual batted	It promotes the use of charging during good times.	No energy costs
Khalkhali et.al	<u>61</u>	2019	Method of the multi-stage for fast charging electric vehicle	Charges are switched when the system produces more renewable energy than is needed.	Electricity storage is the very high cost
Drobnic et.al	<u>62</u>	2019	3 phase grid-tied converters	Avoiding peak hours	Low acceleration
Khan et.al	<u>63</u>	2019	Multi directions, power, and multi-port converter	Unlike gasoline cars, no odors, noises, or complex gear changes exist.	Range anxiety
Stieneker et.al	<u>64</u>	2018	Distribution grids of MVDC	Better battery	Charging the battery is taken more time
Quddus et.al	<u>65</u>	2022	Vehicle-to-grid sources	Electricity consumption is less	High electricity consumption
Muratori et.al	<u>66</u>	2019	Fast charging of direct current	Efficient is high	Less efficient.
Sayed et.al	<u>67</u>	2019	DC microgrid control	Better battery	High energy consumption

**2.3 Solar Electrical Vehicle Using Artificial Neural Network:**

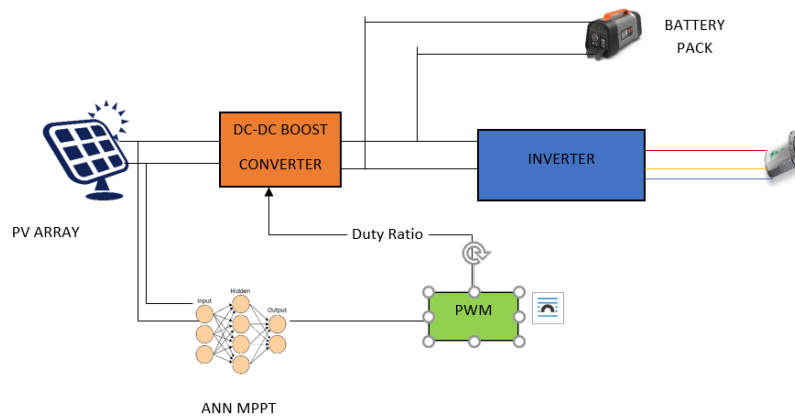

**Figure:3**

Viswa Teja, Anjuru, Wahab Razia Sultana, and Surender Reddy Salkuti.[71]Advantages are anticipated for the suggested approach in a range of electric vehicle (EV) applications where optimal torque and constant velocity are needed to meet load requirements. In order to power the load, the study uses a solar battery connected to an SVPWM inverter and then a DC-DC boost converter. For an electric vehicle (EV) powered by solar energy, a Maximum Power Point Tracking (MPPT) control system based on Artificial Neural Networks (ANNs) is suggested. The effectiveness of the system is assessed by gathering and analyzing data under load conditions that can be adjusted to obtain constant parameters like torque and speed. For this, the MATLAB® Simulink® model was used.

Adedeji, Bukola Peter. [72]Nine virtual functions, derived from the nine chosen parameters by the application of a virtual function formula, comprise the input variables of the proposed model. In order for the artificial neural

network to simulate a unique solution, the number of input variables was set to equal the number of output variables. An artificial neural network's multi-output inverse function model and the suggested model were contrasted. In terms of mean square error, the proposed model's accuracy for the nine case studies under consideration was 1.23–6.85 times greater than the inverse function model.

Elkasrawy, M. A., et al. [73]An artificial neural network (ANN) model is utilized for this, and it is seeded using a pre-generated dataset. When more cars arrive at the station than there are available charging spots, the usefulness of the suggested model can be demonstrated. It was noted that the model's accuracy was 89%. The suggested ANN model's validity was assessed in comparison to a meta-heuristic optimizer, demonstrating a 2.5% reduction in overall charging time and a 23.9% reduction in comparison to a bare model with no optimization.

Swarnamma, C. H. E. L. L. A. P. P. A. N. [74]In addition to controlling the relevant parameters, the model predictive controller has the ability to forecast changes in these parameters in the future—a function that traditional controllers are unable to accomplish. This research aims to offer an ultra-capacitor and battery hybrid energy supply system for electric vehicles. An ANN controller manages the battery and UC's energy, while a traditional PI controller is used to assess it. The simulation results indicate that the ANN controller outperformed the proportional integral (PI) controller in terms of performance. Using MATLAB/Simulink, the complete structure was examined for different battery State of Charge (SoC) scenarios.

Sharma, Neetan, et al. [75]This paper's main goal is to provide the best possible time perspective for small solar power utilities' output forecasts. It has been shown that the most accurate short- to medium-term forecast for April is provided by a time perspective of 5 ms to 12 h. The Peer Panjal region has been the subject of a case study. Comparing the actual solar energy data with the data acquired over a four-month period with different parameters, GD and LM types of artificial neural networks were used to apply the data at random as input data. Unwavering petite term forecasting has been conducted using the suggested ANN-based method. The outcome of the model is displayed as mean absolute percentage error and root mean square error.

Olabi, A. G., et al. [76]This article examines the use of ANNs in several partially shadowed photovoltaic system applications. This paper summarizes and discusses the use of artificial neural networks (ANNs) in Maximum Power Point Tracking (MPPT), fault detection, fault mitigation, system modeling, and performance optimization of solar PV systems subjected to partial shade. In order to advance these methods' development and bring them closer to real-world use, potential avenues for future study are finally discussed.

Mandre, Pooja, et al. [77]An artificial neural network (ANN) is utilized for maximum power point tracking (MPPT) in order to enhance system performance. Because the earth's temperature varies, it is essential to store energy in batteries so that it can be used to its maximum potential. To this end, a bidirectional converter is employed, which stores energy when it surpasses the necessary amount and releases it when needed. Since using a conventional car increases pollution, the Indian government has planned to transition the country to using only electric vehicles (EVs) by 2030. As a result, EV use is increasing. Brushless DC (BLDC) motors are the most common type found in EVs because of their advantages over other motor types.

Yuan, Zixia, Guojiang Xiong, and Xiaofan Fu.[78]This paper examines the state-of-the-art ANN research on PV system failure diagnostics. There is discussion of several popular ANN models, such as MLP, PNN, RBF, CNN, and SAE. Additionally, a survey is conducted on the types of problems, input properties, and diagnostic performance of ANN models. Finally, the main challenges and development trends of ANN applied to the fault diagnosis of PV systems are outlined.

**Table: A literature survey**

Author	Year	Objective	Results	Merits	Demerits
Viswa Teja, Anjuru, Wahab Razia Sultana, and Surender Reddy Salkuti.[71]	2023	Explore PMS motor drive in solar-powered EVs, assess ANN-based MPPT effectiveness.	Designs journal likely showcases improved EV performance with ANN-based MPPT.	Optimize torque, maintain velocity, crucial for EV efficiency, load.	ANN-based MPPT may increase complexity, costs in system implementation.
Adedeji, Bukola Peter.[72]	2023	Develop, compare virtual functions, ANN multi-output inverse function models.	Proposed model outperforms inverse function model, indicating virtual functions' efficacy.	Model uses virtual functions, ANN for tailored solution simulation.	Virtual functions, ANN models may introduce complexity, hindering understanding.

Elkasrawy, M. A., et al.[73]	2023	Utilize ANN for charging optimization, compare with meta-heuristic, bare models.	ANN model: 89% accuracy, 2.5% less time vs. optimizer.	ANN optimizes charging by allocating spots, minimizing wait times.	ANN model's accuracy relies on quality, representativeness of pre-generated dataset.
Swarnamma, C. H. E. L. L. A. P. P. A. N.[74]	2023	Develop UC-battery hybrid system; compare ANN, PI controllers.	ANN outperforms PI in EV energy management, enhancing efficiency.	MPC forecasts future changes, improves energy system management proactively.	Implementing MPC, ANN may increase complexity, development, maintenance costs.
Sharma, Neetan, et al.[75]	2023	Improve solar power output forecasts using ANN in Peer Panjal.	Outcome: MAPE, RMSE used; ANN forecasts, compares actual data.	Optimize forecasting time perspective, enhance solar power output accuracy.	ANN forecasting may require ML, NN expertise, increasing complexity.
Olabi, A. G., et al.[76]	2023	Investigate ANN use in partially shadowed PV system operations.	Paper discusses ANNs' efficacy in partially shadowed PV systems.	ANNs address various aspects of partially shadowed PV systems.	ANNs may complicate PV system implementation, requiring specialized expertise.
Mandre, Pooja, et al.[77]	2023	Enhance solar system with ANN MPPT, optimize battery storage.	Study highlights ANN, bidirectional converters' effectiveness in solar systems.	ANN MPPT and bidirectional converters optimize system performance.	ANN-based MPPT, bidirectional converters add complexity, expertise, costs.
Yuan, Zixia, Guojiang Xiong, and Xiaofan Fu.[78]	2022	Enhance solar system with ANN MPPT, optimize battery storage.	Study showcases ANN, bidirectional converters in solar system optimization.	ANN MPPT, bidirectional converters optimize energy system performance.	ANN-based MPPT, bidirectional converters add complexity, expertise, costs.

#### 2.4 Grid Electric Vehicle Using Artificial Neural Network

Ramasamy, Latha, Navaneethan Soundirarajan, and R. J. Varsha. [79]In both Grid to Vehicle (G2V) and Vehicle to Grid (V2G) modes, the ANN model generates the necessary duty cycle to supply the maximum power. To predict the duty cycle of the bidirectional converter, the artificial neural network is trained using the measured battery voltages and current. This paper presents the neural network implementation, and Matlab/Simulink is used to achieve the simulation results. The practicality and efficacy of the proposed control mechanism are validated by the simulation results. A comparison analysis is conducted to demonstrate how the suggested controller performs better than the traditional Proportional-Integral (PI) controller.

Singh, Abhishek Pratap, and Yogendra Kumar.[80]For DC microgrid-based EVCS, an artificial neural network (ANN)-based adaptive interaction active power management controller (APMC) is suggested. There are three ways of functioning for it. The available PV power and the SBS's current charge level determine the mode of operation. The PV array and SBS are the ideal sources of power for this APMC. Power is taken from the grid if the PV and battery power are insufficient to meet the demand. Excess power from a solar PV system is fed into the grid when it is generated and the SBS is fully charged. MATLAB Simulink is used to test the proposed APMC in three different modes.

Olca, Kadir, and Nurettin Çetinkaya.[81]Using IEEE 6-, 14-, and 30-bus test power systems, the study focuses on the harmonic impacts of EV charging stations at lower voltage levels and at the point where they are linked to the grid. When a single electric vehicle supplied electricity from the grid and the grid was not replaced, these effects have demonstrated how these charging stations on the grid have changed, taking into account the fact that the number of electric vehicles and the number of charging stations rose over the years. Artificial neural networks have been used to forecast and analyze the network's response to the additional load that will occur on

top of the current loads, as well as the harmonic effects and effects of the current grid on the growth rate of electric vehicles over time. Suggestions for power networks in comparable circumstances are provided. Afzal, Muhammad Zeshan, et al.[82]In this study, we provide a novel battery management system (BMS) for electric vehicles. We successfully deployed and tested our recommended BMS on a 100 kWh lithium-ion battery pack. The results demonstrate a startling 15% increase in overall energy efficiency when compared to normal BMS systems. Not only that, but the adaptive virtual admission function increased battery life by 20%. These significant increases in battery longevity and energy efficiency show how effective our BMS is in comparison to other systems. All things considered, the suggested BMS is a noteworthy advancement in the realm of battery management for electric vehicles. For the management of EV battery cells, this combination of ANN and adaptive droop control theory based on fuzzy logic offers a very effective, dependable, and affordable solution.

Adedeji, Bukola Peter. [83]Nine virtual functions, derived from the nine chosen parameters by the application of a virtual function formula, comprise the input variables of the proposed model. In order for the artificial neural network to simulate a unique solution, the number of input variables was set to equal the number of output variables. An artificial neural network's multi-output inverse function model and the suggested model were contrasted. In terms of mean square error, the proposed model's accuracy for the nine case studies under consideration was 1.23–6.85 times greater than the inverse function model.

Safari, Amin, Farshad Babaei, and Meisam Farrokhifar. [84]In addition to proposing a model for EVs to contribute to the LFC system, the goal of this work is to construct an efficient PID controller for LFC in an island Micro-grid (MG). In order to do this, the artificial neural network (ANN) technique known as particle swarm optimization (PSO) is taken into consideration for fine-tuning the PID controller's settings in the MG structure. Simulation findings show that the system becomes stable in the least amount of time when using PSO-based ANN. Furthermore, there is a decrease in the size, overshoot, and settling time of frequency oscillations.

Bonfitto, Angelo.[85]In hybrid and fully electric vehicles, a method for estimating the state of charge (SOC) and state of health (SOH) of batteries is proposed in this study. Training datasets gathered during the experimental characterizations carried out in a lab setting are used to create the networks. The study utilized a lithium battery pack that is intended to provide and retain energy in a mild hybrid electric car. The estimation method is validated using actual driving profiles that are collected while a vehicle is in motion. The combined SOC and SOH estimator's acquired accuracy of about 97% is in compliance with industry standards in the automobile industry. The encouraging accuracy results motivate further experimental validation through a car battery management system deployment.

Hafeez, Ghulam, et al. [86]The proposed DA-GmEDE based strategy is compared with two benchmark strategies: day-ahead genetic algorithm (DA-GA) based strategy, and day-ahead game-theory (DA-game-theoretic) based strategy for performance validation. Moreover, extensive simulations are conducted to test the effectiveness and productiveness of the proposed DA-GmEDE based strategy for efficient energy management. The results and discussion illustrate that the proposed DA-GmEDE strategy outperforms the benchmark strategies by 33.3% in terms of efficient energy management.

**Table :A literature survey**

Author	Year	Objective	Results	Merits	Demerits
Ramasamy, Latha, Navaneethan Soundirarajan, and R. J. Varsha.[79]	2024	Implement ANN for bidirectional converter control, validate efficacy.	Simulation confirms ANN control's efficacy, outperforming traditional PI.	ANN optimizes bidirectional converter duty cycles, enhancing energy transfer.	ANN control may complicate system design, increase development costs.
Singh, Abhishek Pratap, and Yogendra Kumar.[80]	2024	Propose ANN-based APMC for DC microgrid EVCS. Utilize PV and SBS efficiently, manage power flow.	MATLAB Simulink validates APMC efficiency in DC microgrid EVCS.	APMC optimizes power flow, minimizes grid reliance, maximizes renewables.	ANN-based APMC may increase complexity, expertise, costs.
Olcay, Kadir, and Nurettin Çetinkaya.[81]	2023	Analyze EV charging's harmonic impacts, propose grid suggestions.	Study shows EV charging's harmonic impacts, forecasts grid response.	Study assesses EV charging's harmonic impacts across IEEE systems.	ANN implementation may complicate analysis, demand specialized expertise.

Afzal, Muhammad Zeshan, et al.[82]	2023	Propose BMS to enhance EV efficiency, prolong battery life.	Results show 15% efficiency boost, 20% battery life extension.	Suggested BMS boosts efficiency, enhances vehicle performance.	Advanced control algorithms increase complexity, expertise, costs.
Adedeji, Bukola Peter.[83]	2023	Develop ANN model with nine virtual functions, compare accuracy.	Proposed model excels, shows superior accuracy.	Proposed model shows superior accuracy, captures complex relationships.	Implementation may raise complexity, demand expertise, elevate costs.
Safari, Amin, Farshad Babaei, and Meisam Farrokhifar.[84]	2021	Propose EVs in MG for LFC, optimize PID controller.	PSO-based ANN enhances stability, reduces settling time.	PSO-based ANN improves stability, reduces settling time.	PSO-based ANN may increase complexity, expertise, costs.
Bonfitto, Angelo.[85]	2020	Estimate SOC and SOH in electric vehicles, validate method.	97% accuracy achieved, meets industry standards, encourages further validation.	Method achieves 97% accuracy, suitable for hybrid vehicles.	Method implementation may raise complexity, expertise, and costs.
Hafeez, Ghulam, et al.[86]	2020	Compare proposed strategy with benchmarks for energy management validation.	DA-GmEDE outperforms benchmarks, achieves 33.3% energy improvement.	Proposed strategy surpasses benchmarks, indicating effective energy optimization.	Implementation may raise complexity, expertise, and costs in development.

### 3-Problem Statement:

The surge towards electric mobility within the global automotive sector has heightened the demand for efficient and sustainable charging infrastructure tailored for electric vehicles (EVs). Fast charging systems play a pivotal role in alleviating concerns such as range anxiety, fostering the widespread adoption of EVs. However, the incorporation of renewable energy, particularly solar, into fast charging systems poses a range of challenges and opportunities that warrant in-depth exploration.

Despite the increasing interest in utilizing a combination of solar and grid sources to power fast charging stations for EVs, there is a noticeable absence of a comprehensive survey within the existing literature that assesses the state-of-the-art in fast charging systems utilizing both solar and grid energy sources. This research endeavors to bridge this gap by delving into the technological, economic, and environmental facets associated with such charging systems.

The exploration of key challenges encompasses comprehending the intermittency of solar power, evaluating energy conversion efficiency, assessing the economic feasibility of dual-source systems, and scrutinizing the overall impact on the electricity grid. Furthermore, user-centric considerations such as the charging experience, convenience, and user satisfaction require thorough investigation to ensure the smooth integration and widespread acceptance of these advanced charging solutions.

This survey aims to provide a holistic understanding of the current landscape, identify crucial challenges, and propose innovative strategies in the design, implementation, and optimization of fast charging systems for EVs utilizing both solar and grid sources. The anticipated outcomes of this research are poised to offer valuable insights to policymakers, industry stakeholders, and researchers, illuminating the present state and future potential of sustainable and efficient EV charging infrastructure.

### 4. Performance valuation

Fast charging systems designed for electric vehicles (EVs) can take advantage of both solar and grid sources, offering efficient and sustainable charging options. Placing solar panels strategically, such as on parking structures or dedicated carports, allows these systems to capture sunlight using photovoltaic cells, converting it into electricity. The generated solar power seamlessly becomes part of the charging infrastructure. Ensuring a

continuous power supply, the system is smartly linked to the electrical grid, supplementing solar energy during periods of low sunlight or high demand. Additionally, there's the option to integrate an energy storage system, like batteries, enhancing reliability by storing excess solar energy for future use. This holistic approach not only facilitates fast charging through advanced power electronics managing power distribution to vehicles but also incorporates smart grid technology to optimize charging processes in real-time. This integration considers variables such as grid demand, electricity prices, and solar power availability. The outcome is a charging solution that is both user-friendly and sustainable, reducing reliance on grid electricity and contributing to the overall resilience and environmental sustainability of the energy infrastructure.

The gained performance of the fast charging system with EVs is analyzed and examined. Also compare the performances such as power, voltage, current, efficiency, capacity, and time of several existing approaches. Thus the comparison results of power are detailed in Fig.1.

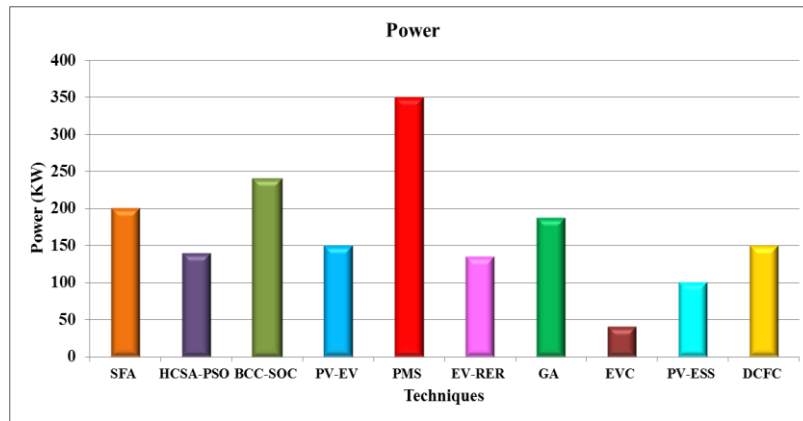

**Fig.1 Power Comparison**

Moreover, the SFA model gained 200kW, the HCSA-PSO technique attained 140kW, the BCC-SOC technique attained 240kW, the PV-EV model gained 150kW, the PMS model achieved 350kW, the EV-RER technique gained 135kW, GA model achieved 187.5kW, EVC technique reached 40kW, PV-ESS model gained 100kW, and DCFC model gained 150kW for power. The PMS (Power Management System) model reached a significant milestone by achieving a power output of 350 kilowatts (kW). This substantial accomplishment highlights the model's efficiency in managing and distributing electrical power effectively. The 350kW output underscores the model's ability to handle substantial electrical loads and optimize power distribution, making it particularly suitable for applications where robust power management is essential. A more in-depth examination of the distinct features and functionalities incorporated into the PMS model would offer valuable insights into its capabilities and potential applications across various energy systems.

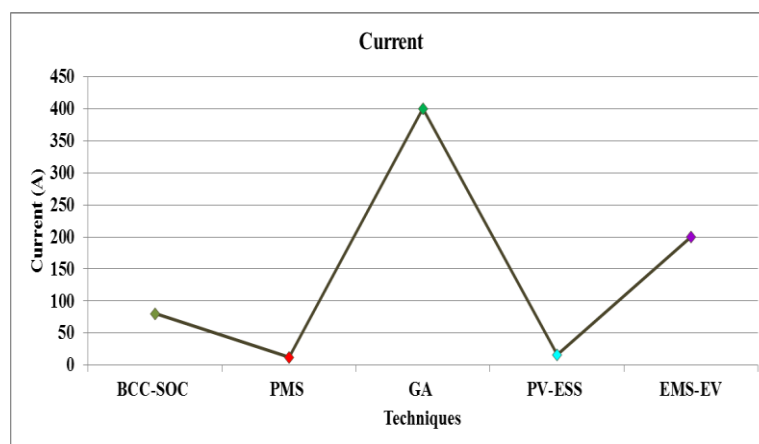

**Fig.2 Current comparison**

The comparison result is detailed in Fig. 2. The BCC-SOC model attained 80A, the PMS technique required 12A, the GA model gained 400A, the PV-ESS model attained 16A, and the EMS-EV technique attained 200 A current. The GA model showcased a significant upswing, registering a current of 400A, indicating a substantial boost in its power utilization or production. This heightened current capacity implies the model's aptitude for managing

more substantial workloads or tasks requiring increased electrical currents. A comparison with alternative models like BCC-SOC (80A) and PMS technique (12A) accentuates the unique current demands and performance attributes of the GA model in the assessed scenario. These observations provide valuable perspectives on the relative capabilities and effectiveness of each model in the comparative analysis.

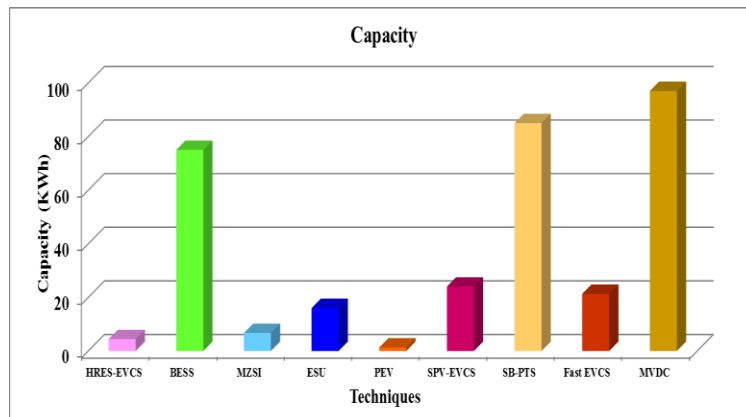

**Fig.3 Capacity comparison**

The comparison result of capacity is detailed in Fig. 3. Additionally, the HRES-EVCS model attained 4.4 KWh, the BESS model attained 75 KWh, the MZSI model attained 6.7 KWh, the ESU model attained 16 KWh, the PEV model achieved 1.3 KWh, SPV-EVCS model attained 24 KWh, SB-PTS model attained 85 KWh, Fast EVCS model attained 21.3 KWh, and MVDC model attained 97 KWh for capacity. The MVDC (Medium Voltage Direct Current) model has demonstrated a noteworthy capacity of 97 kilowatt-hours (KWh). This considerable capacity highlights the model's effectiveness in managing and supplying a substantial quantity of electrical energy for applications that demand medium-voltage direct current. The significant capacity suggests that the MVDC model is well-suited for a variety of demanding scenarios, including large-scale industrial applications and advanced energy storage systems. Gaining insights into the distinct features and design aspects of the MVDC model would be instrumental in understanding its strong performance and its potential role in improving energy infrastructure and various applications.

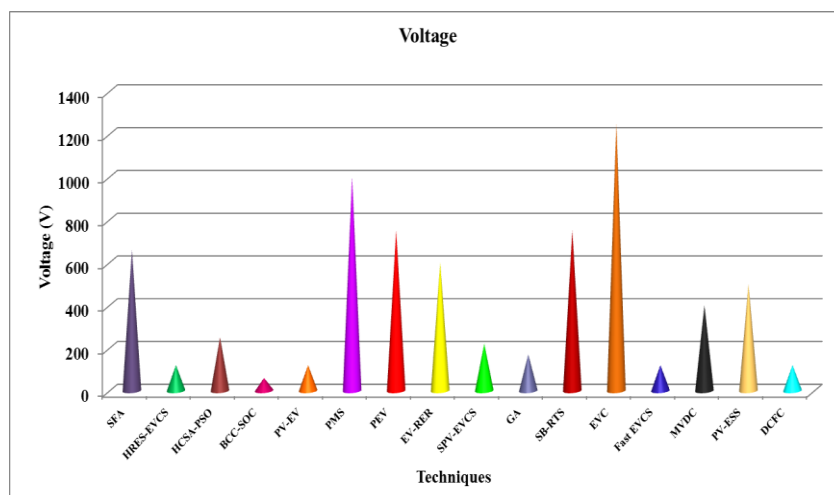
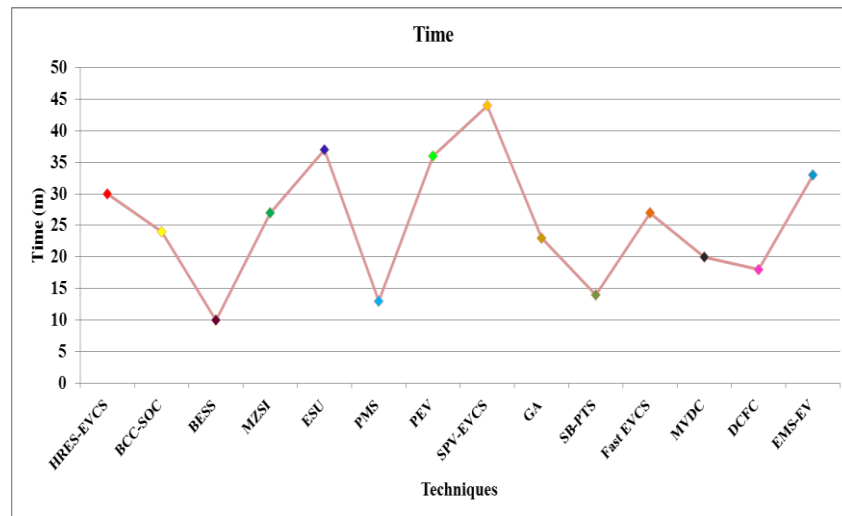

**Fig.4 Voltage comparison**

The comparison result of voltage is detailed in Fig. 4. Moreover, the SFA model gained 600V, the HRES-EVCS model gained 120V, the HCSA-PSO technique attained 250V, the BCC-SOC technique attained 60V, the PV-EV model gained 120V, PMS model achieved 1000V, PEV model earned 750V, EV-RER technique gained 600V, SPV-EVCS technique gained 220V, GA model achieved 170V, SB-RTS technique achieved 750V, EVC technique attained 1250V, Fast EVCS technique gained 120V, MVDC model earned 400V, PV-ESS model gained 500V, and DCFC model gained 120V for voltage. The EVC (Electric Vehicle Charging) technique successfully reached a notable voltage of 1250 volts (V), demonstrating its remarkable proficiency in managing elevated electrical potentials. This substantial voltage accomplishment implies that the EVC technique is aptly designed for applications demanding substantial electric charging power, especially in situations involving high-voltage charging for electric vehicles. The achievement of 1250V underscores the technique's effectiveness in delivering robust charging capabilities, potentially contributing to faster and more powerful charging solutions



for electric vehicles. Exploring the specific design features and operational mechanisms of the EVC technique would provide valuable insights into its capacity to attain and handle such elevated voltage levels.



**Fig.5 time comparison**

The comparison result of time is detailed in Fig. 5. Moreover, the HRES-EVCS model gained 30m, the BCC-SOC model gained 24m, the BESS technique attained 10m, the MZSI technique reached 27m, the ESU model gained 37m, the PMS model achieved 13m, PEV model attained 36m, SPV-EVCS technique gained 44m, GA model reached 23m, SB-PTS technique achieved 14m, Fast EVCS technique gained 27m, MVDC model attained 20m, and DCFC model gained 18m. EMS-EV model gained 33m for fast charging. The SPV-EVCS (Solar Photovoltaic-Electric Vehicle Charging System) technique has demonstrated a 44-millivolt (mV) gain, indicating its adeptness in capturing and utilizing solar energy for electric vehicle charging. This subtle yet noteworthy increase in voltage underscores the technique's efficacy in harnessing solar power and converting it into electric charge. The 44mV gain emphasizes the SPV-EVCS technique's ability to make incremental contributions to the charging process, aligning with its role in promoting sustainable and eco-friendly electric vehicle infrastructure. A more in-depth examination of the specific mechanisms and components employed in the SPV-EVCS technique would offer a comprehensive understanding of its capacity for efficiently utilizing solar energy in electric vehicle charging.

### 5-Challenges and limitations

The survey of fast charging systems in electrical vehicles (EVs) utilizing both solar and grid sources reveals a multitude of challenges and limitations that need careful consideration for the advancement of sustainable transportation. One prominent challenge is the intermittent nature of solar power generation. The reliance on sunlight introduces variability in charging efficiency, particularly during adverse weather conditions or at night, necessitating supplementary grid support to ensure consistent availability of power for EV charging.

Grid-dependent systems face limitations linked to power grid capacity and peak demand. As the number of EVs increases, the strain on the existing grid infrastructure can lead to potential bottlenecks and reduced charging efficiency, especially during periods of high demand. The need for substantial upgrades to the electrical grid to accommodate the growing EV fleet poses a significant challenge, requiring strategic planning and investment.

The economic aspect presents another set of challenges, with the implementation costs of dual-charging infrastructure being a barrier to widespread adoption. Integrating both solar and grid sources requires significant capital investment for the installation of solar panels, energy storage systems, and the necessary grid infrastructure. Balancing the economic feasibility with the environmental benefits remains a critical consideration in the broader deployment of these systems.

Firstly, the dependence on solar energy introduces variability due to weather conditions and time of day. While solar panels can generate electricity during the day, their efficiency diminishes during cloudy or nighttime conditions, impacting the charging rate. This intermittency poses a challenge in ensuring consistent and reliable fast charging experiences for EV users, particularly during periods of high demand or unfavorable weather.

Secondly, integrating solar energy with grid sources necessitates complex system design and management. Coordination between solar generation, battery storage, and grid connectivity is crucial to optimize charging efficiency and minimize grid dependency. Achieving seamless transitions between solar and grid power, especially during peak demand or insufficient sunlight, requires sophisticated control algorithms and energy

management systems. Moreover, ensuring grid stability and mitigating potential issues such as voltage fluctuations or overloading due to fast charging demand impose additional technical challenges. Lastly, the scalability and cost-effectiveness of solar-integrated fast charging systems remain significant hurdles. While solar energy offers long-term environmental and economic benefits, the upfront costs associated with installing solar panels and requisite infrastructure can be prohibitive. Moreover, balancing the capacity of solar generation, battery storage, and grid connection to meet varying demand levels without overprovisioning adds complexity and cost.

Furthermore, technological challenges such as interoperability issues and the lack of standardized protocols pose obstacles to seamless integration and user experience. The absence of universally accepted standards may hinder the development of a cohesive and efficient charging infrastructure. Addressing these multifaceted challenges is imperative to realizing the full potential of fast charging systems in electrical vehicles using solar and grid sources, ultimately fostering a sustainable and reliable future for electric transportation.

## 6. Future research and development

EVs can be viewed as valuable assets in an intelligent grid setting. They can be viewed as a way to balance power variations brought on by a greater reliance on erratic and inconsistent RES [68]. But, the widespread adoption of EVs burdens the power grid, causing unneeded congestion, voltage drops, and other adverse effects on the distribution system [69]. This problem presents a variety of difficulties for power system operators. Therefore, smart charging technology should be improved for use in future studies. In addition, by employing practical optimization approaches, the placement and size of charging stations should be optimized to minimize grid-related problems and maximize economic benefits [70]. Therefore, research on cost function improvement and optimization problems in charging station are possible.

Fast charging systems integrating solar and grid power in electric vehicles are an important area of research and development. These systems can reduce transportation's environmental impact and improve electric vehicles' efficiency and convenience. Efficient integration of solar and grid power is a significant challenge in this field, requiring advanced power electronics and control systems to manage the flow of electricity and optimize the charging process. Future studies in this field will concentrate on developing power electronics, grid integration, and solar integration technologies. Advancements in battery technology will be critical for developing high-capacity, fast-charging batteries that can withstand high currents and voltages. Advanced power electronics components and control systems are essential for managing the flow of electricity in fast-charging systems. To ensure efficient integration with the grid, research will focus on developing new algorithms and control systems that can optimize the charging process and minimize the impact on the grid.

Similarly, integrating solar power into fast charging systems will require developing new solar panel technologies and control systems to manage the flow of solar energy. Overall, fast charging systems using solar and grid power in electric vehicles is an exciting and rapidly evolving field of research. They will likely play a critical role in transitioning to a more sustainable and environmentally friendly transportation system.

## 7. Conclusions

EV technology's advantages for the environment have increased interest in it recently. However, the improvements in EV charging systems call for a thorough study of the subject and initiatives for their widespread use. This article examines the advancements in rapid EV charging networks, charging methods, and set global standards, along with a full assessment of the challenges and opportunities specified. Despite the financial and environmental advantages, integrating EVs into the power grid may have unfavorable effects on how the current electrical network operates regarding network loading, voltage variations, and power quality. Along with the solutions suggested in the literature to address these adverse effects, these negative effects are examined in detail. Utilizing energy storage devices and RES with charging systems, among other demand control techniques, are also covered. However, several things could still be improved with the infrastructure for charging EVs.

A more specialized framework was needed for the EMS of EVs to address the multilayer variables relating to RES, arrival and departure trends, and other aspects. To accurately reflect EV load in power system stability studies, an accurate load model must be created. Fast DC charging infrastructure for energy storage systems is still under development and requires in-depth analysis. There is potential to develop new approaches with the primary goal of avoiding new peaks because the majority of EMS in EV efforts is based on price signal plans also concentrated on decreasing operating costs. Additionally, current difficulties with battery degradation should be included in optimization techniques for the charging, discharging, and synchronizing of EVs. This endeavor is expected to encourage additional research on FCS in EV and provide the most relevant and significant data.

### ***Compliance with Ethical Standards***

#### *Conflict of interest*

The authors declare that they have no conflict of interest.

#### *Human and Animal Rights*

This article does not contain any studies with human or animal subjects performed by any of the authors.

#### *Informed Consent*

Informed consent does not apply as this was a retrospective review with no identifying patient information.

**Funding:** Not applicable

**Conflicts of interest Statement:** Not applicable

**Consent to participate:** Not applicable

**Consent for publication:** Not applicable

**Availability of data and material:**

Data sharing is not applicable to this article as no new data were created or analyzed in this study.

**Code availability:** Not applicable

#### **References**

- [1] Gorbunova, A. D., and I. A. Anisimov. "Assessment of the use of renewable energy sources for the charging infrastructure of electric vehicles." *Emerging Science Journal* 4.6 (2020): 539-550.
- [2] Falkoni, Anamarija, Antun Pfeifer, and GoranKrajačić. "Vehicle-to-grid in standard and fast electric vehicle charging: Comparison of renewable energy source utilization and charging costs." *Energies* 13.6 (2020): 1510.
- [3] Elma, Onur, and Hossam A. Gabbar. "Sizing analysis of hybrid DC fast charging system for electric vehicles." 2018 International Conference on Smart Energy Systems and Technologies (SEST). IEEE, 2018.
- [4] Tavakoli, Ahmad, et al. "Impacts of grid integration of solar PV and electric vehicle on grid stability, power quality and energy economics: A review." *IET Energy Systems Integration* 2.3 (2020): 243-260.
- [5] Kalla, Ujjwal Kumar, and TanmayShukla. "State of Art and Comprehensive Study on Charging Systems for Electric Vehicles." 2021 International Conference on Sustainable Energy and Future Electric Transportation (SEFET). IEEE, 2021.
- [6] Nasr Esfahani, Fatemeh, Ahmed Darwish, and Barry W. Williams. "Power converter topologies for grid-tied solar photovoltaic (PV) powered electric vehicles (EVs)—a comprehensive review." *Energies* 15.13 (2022): 4648.
- [7] Raj, JS SakthiSuriya, et al. "Wide Band Gap semiconductor material for electric vehicle charger." *Materials Today: Proceedings* 45 (2021): 852-856.
- [8] Hemavathi, S., and A. Shinisha. "A study on trends and developments in electric vehicle charging technologies." *Journal of Energy Storage* 52 (2022): 105013.
- [9] Muttaqi, Kashem M., MdRabiul Islam, and Danny Sutanto. "Future power distribution grids: Integration of renewable energy, energy storage, electric vehicles, superconductor, and magnetic bus." *IEEE Transactions on Applied Superconductivity* 29.2 (2019): 1-5.
- [10] Joseph, Peter K., ElangovanDevaraj, and ArunkumarGopal. "Overview of wireless charging and vehicle-to-grid integration of electric vehicles using renewable energy for sustainable transportation." *IET Power Electronics* 12.4 (2019): 627-638.
- [11] SatyaPrakashOruganti, Kameswara, ChockalingamAravindVaithilingam, and GowthamrajRajendran. "Design and sizing of mobile solar photovoltaic power plant to support rapid charging for electric vehicles." *Energies* 12.18 (2019): 3579.
- [12] Al Wahedi, Abdulla, and Yusuf Bicer. "Development of an off-grid electrical vehicle charging station hybridized with renewables including battery cooling system and multiple energy storage units." *Energy Reports* 6 (2020): 2006-2021.
- [13] Olatunde, Oladepo, et al. "Hybrid photovoltaic/small-hydropower microgrid in smart distribution network with grid isolated electric vehicle charging system." *Journal of Energy Storage* 31 (2020): 101673.
- [14] Shariff, Samir M., et al. "System design and realization of a solar-powered electric vehicle charging station." *IEEE Systems Journal* 14.2 (2019): 2748-2758.
- [15] Singh, Arshdeep, and ShimiSudha Letha. "Emerging energy sources for electric vehicle charging station." *Environment, Development and Sustainability* 21.5 (2019): 2043-2082.
- [16] Singh, Arshdeep, and ShimiSudha Letha. "Emerging energy sources for electric vehicle charging station." *Environment, Development and Sustainability* 21.5 (2019): 2043-2082.
- [17] Cheikh-Mohamad, Saleh, et al. "PV-powered electric vehicle charging stations: Preliminary requirements and feasibility conditions." *Applied Sciences* 11.4 (2021): 1770.
- [18] Yang, Qiang, et al. "Optimal sizing of PEV fast charging stations with Markovian demand characterization." *IEEE Transactions on Smart Grid* 10.4 (2018): 4457-4466.
- [19] Schroeder, Andreas, and ThureTraber. "The economics of fast charging infrastructure for electric vehicles." *Energy Policy* 43 (2012): 136-144.
- [20] Arfeen, Zeeshan Ahmad, et al. "Novel Supervisory Management Scheme of Hybrid Sun Empowered Grid-Assisted Microgrid for Rapid Electric Vehicles Charging Area." *Applied Sciences* 11.19 (2021): 9118.
- [21] Chakraborty, Sajib, et al. "DC-DC converter topologies for electric vehicles, plug-in hybrid electric vehicles and fast charging stations: State of the art and future trends." *Energies* 12.8 (2019): 1569.
- [22] Iyer, Vishnu Mahadeva, et al. "An approach towards extreme fast charging station power delivery for electric vehicles with partial power processing." *IEEE Transactions on Industrial Electronics* 67.10 (2019): 8076-8087.
- [23] He, Yawei, Kara M. Kockelman, and Kenneth A. Perrine. "Optimal locations of US fast charging stations for long-distance trip completion by battery electric vehicles." *Journal of cleaner production* 214 (2019): 452-461.
- [24] Nicholas, Michael, and Dale Hall. "Lessons learned on early electric vehicle fast-charging deployments." *International Council on Clean Transportation* (2018): 7-26.
- [25] Dong, Xiaohong, et al. "A charging pricing strategy of electric vehicle fast charging stations for the voltage control of electricity distribution networks." *Applied energy* 225 (2018): 857-868.

- [26] Gnann, Till, et al. "Fast charging infrastructure for electric vehicles: Today's situation and future needs." *Transportation Research Part D: Transport and Environment* 62 (2018): 314-329.
- [27] Bryden, Thomas S., et al. "Electric vehicle fast charging station usage and power requirements." *Energy* 152 (2018): 322-332.
- [28] González, L. G., E. Siavichay, and J. L. Espinoza. "Impact of EV fast charging stations on the power distribution network of a Latin American intermediate city." *Renewable and Sustainable Energy Reviews* 107 (2019): 309-318.
- [29] Xie, Fei, et al. "Long-term strategic planning of inter-city fast charging infrastructure for battery electric vehicles." *Transportation Research Part E: Logistics and Transportation Review* 109 (2018): 261-276.
- [30] He, Yi, Ziqi Song, and Zhaocai Liu. "Fast-charging station deployment for battery electric bus systems considering electricity demand charges." *Sustainable Cities and Society* 48 (2019): 101530.
- [31] Luo, Lizi, et al. "Optimal planning of electric vehicle charging stations comprising multi-types of charging facilities." *Applied Energy* 226 (2018): 1087-1099.
- [32] Engel, Hauke, et al. "Charging ahead: Electric-vehicle infrastructure demand." *McKinsey Center for Future Mobility* 8 (2018).
- [33] Srdic, Srdjan, and SrdjanLukic. "Toward extreme fast charging: Challenges and opportunities in directly connecting to medium-voltage line." *IEEE Electrification Magazine* 7.1 (2019): 22-31.
- [34] Globisch, Joachim, et al. "Consumer preferences for public charging infrastructure for electric vehicles." *Transport Policy* 81 (2019): 54-63.
- [35] Yang, Qiang, et al. "Optimal sizing of PEV fast charging stations with Markovian demand characterization." *IEEE Transactions on Smart Grid* 10.4 (2018): 4457-4466.
- [36] Niharika, Raghunath, KM SaiPavan, and P. V. Manitha. "Development of Fast charging system with ZVS integrated with Fuzzy controller-based Hybrid renewable energy source." *Journal of Physics: Conference Series*. Vol. 2070. No. 1. IOP Publishing, 2021.
- [37] Goswami, Anik, and Pradip Kumar Sadhu. "Stochastic firefly algorithm enabled fast charging of solar hybrid electric vehicles." *Ain Shams Engineering Journal* 12.1 (2021): 529-539.
- [38] Bastida-Molina, Paula, et al. "Multicriteria power generation planning and experimental verification of hybrid renewable energy systems for fast electric vehicle charging stations." *Renewable Energy* 179 (2021): 737-755.
- [39] Ray, Priyanka, ChayanBhattacharjee, and KoteswaraRajuDhenuvakonda. "Swarm intelligence-based energy management of electric vehicle charging station integrated with renewable energy sources." *International Journal of Energy Research* (2021).
- [40] Kumar, Nikhil, et al. "A comprehensive planning framework for electric vehicles fast charging station assisted by solar and battery based on Queueing theory and non-dominated sorting genetic algorithm-II in a co-ordinated transportation and power network." *Journal of Energy Storage* 49 (2022): 104180.
- [41] Sabarimuthu, M., and N. Senthilnathan. "Development of fast and hybrid charger for lithium ion batteries in light weight electric vehicles." *International Transactions on Electrical Energy Systems* 31.7 (2021): e12932.
- [42] Ramanathan, G., et al. "Implementation of modified Z-source inverter integrated for electric vehicle fast charging." *Materials Today: Proceedings* 65 (2022): 265-270.
- [43] Eltoumi, Fouad M., et al. "The key issues of electric vehicle charging via hybrid power sources: Techno-economic viability, analysis, and recommendations." *Renewable and Sustainable Energy Reviews* 138 (2021): 110534.
- [44] Narasipuram, RajanandPatnaik, and SubbaraoMopidevi. "A technological overview & design considerations for developing electric vehicle charging stations." *Journal of Energy Storage* 43 (2021): 103225.
- [45] Krishnan Nair, Divya, Krishnamachar Prasad, and Tek T. Lie. "Standalone electric vehicle charging station using an isolated bidirectional converter with snubber." *Energy Storage* 3.5 (2021): e255.
- [46] Nishanth, Jayasankar, et al. "Techno-economic analysis of a hybrid solar wind electric vehicle charging station in highway roads." *International Journal of Energy Research* 46.6 (2022): 7883-7903.
- [47] Ahmadi, Miad, et al. "Integration of Distributed Energy Resources and EV Fast-Charging Infrastructure in High-Speed Railway Systems." *Electronics* 10.20 (2021): 2555.
- [48] Assolami, Yasser O., Ahmed Gaouda, and Ramadan El-Shatshat. "A New Framework for Plug-In Electric Vehicle Charging Models Supported by Solar Photovoltaic Energy Resources Un nouveau cadre pour les modèles de recharge du véhicule électrique rechargeable supporté par des ressources d'énergie solaire photovoltaïque." *IEEE Canadian Journal of Electrical and Computer Engineering* 44.2 (2021): 118-129.
- [49] Salkuti, Surender Reddy. "Energy storage and electric vehicles: technology, operation, challenges, and cost-benefit analysis." *International Journal of Advanced Computer Science and Applications* 12.4 (2021).
- [50] Gupta, Rudraksh S., ArjunTyagi, and S. Anand. "Optimal allocation of electric vehicles charging infrastructure, policies and future trends." *Journal of Energy Storage* 43 (2021): 103291.
- [51] Elma, Onur. "A dynamic charging strategy with hybrid fast charging station for electric vehicles." *Energy* 202 (2020): 117680.
- [52] Prem, P., et al. "Fast charging converter and control algorithm for solar PV battery and electrical grid integrated electric vehicle charging station." *Automatika* 61.4 (2020): 614-625.
- [53] Mahfouz, Mostafa M., and M. Reza Irvani. "Grid-integration of battery-enabled dc fast charging station for electric vehicles." *IEEE Transactions on Energy Conversion* 35.1 (2019): 375-385.
- [54] Colmenar-Santos, Antonio, et al. "Electric vehicle charging strategy to support renewable energy sources in Europe 2050 low-carbon scenario." *Energy* 183 (2019): 61-74.
- [55] Domínguez-Navarro, J. A., et al. "Design of an electric vehicle fast-charging station with integration of renewable energy and storage systems." *International Journal of Electrical Power & Energy Systems* 105 (2019): 46-58.
- [56] Kong, Weiwei, et al. "Optimal location planning method of fast charging station for electric vehicles considering operators, drivers, vehicles, traffic flow and power grid." *Energy* 186 (2019): 115826.

- [57] Sami, I., et al. "A bidirectional interactive electric vehicles operation modes: Vehicle-to-grid (V2G) and grid-to-vehicle (G2V) variations within smart grid." 2019 International Conference on Engineering and Emerging Technologies (ICEET). IEEE, 2019.
- [58] Mastoi, Muhammad Shahid, et al. "An in-depth analysis of electric vehicle charging station infrastructure, policy implications, and future trends." *Energy Reports* 8 (2022): 11504-11529.
- [59] Khan, Wajahat, Furkan Ahmad, and Mohammad SaadAlam. "Fast EV charging station integration with grid ensuring optimal and quality power exchange." *Engineering Science and Technology, an International Journal* 22.1 (2019): 143-152.
- [60] Wang, Shuoqi, et al. "Virtual-battery based droop control and energy storage system size optimization of a DC microgrid for electric vehicle fast charging station." *Applied Energy* 259 (2020): 114146.
- [61] Khalkhali, Hassan, and SeyedHosseinHosseini. "Multi-stage stochastic framework for simultaneous energy management of slow and fast charge electric vehicles in a restructured smart parking lot." *International Journal of Electrical Power & Energy Systems* 116 (2020): 105540.
- [62] Drobnic, Klemen, et al. "An output ripple-free fast charger for electric vehicles based on grid-tied modular three-phase interleaved converters." *IEEE Transactions on Industry Applications* 55.6 (2019): 6102-6114.
- [63] Khan, ShakilAhamed, et al. "A new isolated multi-port converter with multi-directional power flow capabilities for smart electric vehicle charging stations." *IEEE Transactions on Applied Superconductivity* 29.2 (2019): 1-4.
- [64] Stieneker, Marco, et al. "MVDC distribution grids for electric vehicle fast-charging infrastructure." 2018 International Power Electronics Conference (IPEC-Niigata 2018-ECCE Asia). IEEE, 2018.
- [65] Quddus, Md Abdul, MohannadKabli, and Mohammad Marufuzzaman. "Modeling electric vehicle charging station expansion with an integration of renewable energy and Vehicle-to-Grid sources." *Transportation Research Part E: Logistics and Transportation Review* 128 (2019): 251-279.
- [66] Muratori, Matteo, EleftheriaKontou, and Joshua Eichman. "Electricity rates for electric vehicle direct current fast charging in the United States." *Renewable and Sustainable Energy Reviews* 113 (2019): 109235.
- [67] Sayed, Khairy, Ahmed G. Abo-Khalil, and Ali S. Alghamdi. "Optimum resilient operation and control DC microgrid based electric vehicles charging station powered by renewable energy sources." *Energies* 12.22 (2019): 4240.
- [68] Chen, Xinyu, et al. "Impacts of fleet types and charging modes for electric vehicles on emissions under different penetrations of wind power." *Nature Energy* 3.5 (2018): 413-421.
- [69] Mao, Chengyu, et al. "Identifying the limiting electrode in lithium ion batteries for extreme fast charging." *Electrochemistry Communications* 97 (2018): 37-41.
- [70] Huang, Yantao, and Kara M. Kockelman. "Electric vehicle charging station locations: Elastic demand, station congestion, and network equilibrium." *Transportation Research Part D: Transport and Environment* 78 (2020): 102179.
- [71] Viswa Teja, Anjuru, Wahab Razia Sultana, and Surender Reddy Salkuti. "Performance explorations of a PMS motor drive using an ANN-based MPPT controller for solar-battery powered electric vehicles." *Designs* 7.3 (2023): 79.
- [72] Adedeji, Bukola Peter. "Electric vehicles survey and a multifunctional artificial neural network for predicting energy consumption in all-electric vehicles." *Results in Engineering* 19 (2023): 101283.
- [73] Elkasrawy, M. A., et al. "Real-time optimization in electric vehicle stations using artificial neural networks." *Electrical Engineering* 105.1 (2023): 79-89.
- [74] Swarnamma, C. H. E. L. L. A. P. P. A. N. "ANN Optimized Hybrid Energy Management Control System for Electric Vehicles." *Studies in Informatics and Control* 32.1 (2023): 101-110.
- [75] Sharma, Neetan, et al. "Solar power forecasting beneath diverse weather conditions using GD and LM-artificial neural networks." *Scientific reports* 13.1 (2023): 8517.
- [76] Olabi, A. G., et al. "Artificial neural networks applications in partially shaded PV systems." *Thermal Science and Engineering Progress* 37 (2023): 101612.
- [77] Mandre, Pooja, et al. "ANN based Solar MPPT for BLDC Motor load using Bidirectional Converter." 2023 IEEE International Students' Conference on Electrical, Electronics and Computer Science (SCEECS). IEEE, 2023.
- [78] Yuan, Zixia, Guojiang Xiong, and Xiaofan Fu. "Artificial neural network for fault diagnosis of solar photovoltaic systems: a survey." *Energies* 15.22 (2022): 8693.
- [79] Ramasamy, Latha, Navaneethan Soundirarajan, and R. J. Varsha. "Artificial Neural Network based Bidirectional Converter Control for Electric Vehicle Charging." *Proceedings of the First International Conference on Science, Engineering and Technology Practices for Sustainable Development, ICSETPSD 2023, 17th-18th November 2023, Coimbatore, Tamilnadu, India. 2024.*
- [80] Singh, Abhishek Pratap, and Yogendra Kumar. "Artificial neural network based active power management controller for electric vehicle charging station." *International Journal of Ambient Energy* 45.1 (2024): 2268102.
- [81] Olcay, Kadir, and Nurettin Çetinkaya. "Analysis of the electric vehicle charging stations effects on the electricity network with artificial neural network." *Energies* 16.3 (2023): 1282.
- [82] Afzal, Muhammad Zeshan, et al. "A novel electric vehicle battery management system using an artificial neural network-based adaptive droop control theory." *International Journal of Energy Research* 2023 (2023): 1-15.
- [83] Adedeji, Bukola Peter. "Electric vehicles survey and a multifunctional artificial neural network for predicting energy consumption in all-electric vehicles." *Results in Engineering* 19 (2023): 101283.
- [84] Safari, Amin, Farshad Babaei, and Meisam Farrokhifar. "A load frequency control using a PSO-based ANN for micro-grids in the presence of electric vehicles." *International Journal of Ambient Energy* 42.6 (2021): 688-700.
- [85] Bonfitto, Angelo. "A method for the combined estimation of battery state of charge and state of health based on artificial neural networks." *Energies* 13.10 (2020): 2548.

- [86] Hafeez, Ghulam, et al. "An innovative optimization strategy for efficient energy management with day-ahead demand response signal and energy consumption forecasting in smart grid using artificial neural network." *IEEE Access* 8 (2020): 84415-84433.
- [87] Sandeep Bishla, Anita Khosla, "Enhanced chimp optimized self-tuned FOPR controller for battery scheduling using Grid and Solar PV Sources" *Journal of Energy Storage*, Volume 66, 2023, 107403, <https://doi.org/10.1016/j.est.2023.107403>
- [88] Sandeep Bishla, Anita Khosla, "Honey badger optimized energy management in grid-connected solar PV battery for enhancing the stability and power quality" *Energy Storage*, Volume 6, Issue 1, Feb'2024, e512, <https://doi.org/10.1002/est.2.512>
- [89] Sandeep Bishla, Anita Khosla, "Review of Power Quality and Stability of EV Charging with Grid and PV Solar" *Energy Technology*, Volume 12, Issue 2, Feb'2024, 2300744, <https://doi.org/10.1002/ente.202300744>
- [90] Sandeep Bishla, Anite Khosla, "108kWp Rooftop PV Solar Plant Designing, Installation and Analysis with Performance Measurements for Industrial Plant in Delhi-NCR," 2024 3rd International Conference on Power Electronics and IoT Applications in Renewable Energy and its Control (PARC), Mathura, India, 2024, pp. 269-274, doi: 10.1109/PARC59193.2024.10486784