

^{1a}Xing Zhang
^{1b}Yunlong Zhou

Analysis of Deep Peak Shaving Methods for Thermal Power Generation Units Based on the Improved Energy Consumption Framework



Abstract: - Because thermal power producing units account for a large portion of the world's energy consumption, their energy consumption is a major concern. Reducing energy consumption and raising the overall efficiency of thermal power production units has become more and more important in recent years. Reducing energy consumption during peak hours is known as bottomless peak shaving, and it is one way to accomplish this. An enhanced framework for energy consumption is presented in this study to assess and examine deep peak shaving techniques for thermal power plants. The framework takes into consideration the various factors that affect energy consumption, such as fuel type, plant size, and external conditions. It also considers the different aspects of peak shaving, such as intensity and duration. Through the use of this framework, various deep peak shaving methods, such as thermal storage systems, load shifting, and demand response, are evaluated. The effectiveness of these methods is assessed based on their impact on energy consumption, cost, and environmental considerations. The framework also takes into account how feasible and useful it would be to apply these techniques in various kinds of thermal power generating units. The analysis's findings demonstrate that deep peak shaving techniques can dramatically lower energy use during peak hours, which can save money and possibly have positive effects on the environment. The best approach would rely on the unique qualities of every thermal power generating unit.

Keywords: Power Generation, Energy Consumption, Environmental Considerations, Individual Characteristics, Peak Periods

1. Introduction

Deep peak shaving methods are techniques used in thermal power generation to reduce energy consumption during peak demand periods by shifting the load to off-peak periods [1]. It not only helps in reducing operating costs but also improves the overall efficiency of the power plant. One of the most commonly used deep peak shaving methods is called "demand response [2]." It involves adjusting the power output of the generation units based on the current demand in the grid. In this method, the plant operators constantly monitor the grid demand and make necessary adjustments to the power output to meet the demand while minimizing energy consumption [3]. Another method for bottomless peak shaving is "thermal storage [4]." It involves storing excess thermal energy during off-peak periods and using it for power generation during peak demand periods [5]. It is usually done by storing hot water or steam in insulated tanks, which can then be used to power turbines when needed instead of using new fuel [6]. Cogeneration is another technique that can help reduce peak demand. In this method, the heat generated during power generation is used for other industrial or residential purposes, such as heating buildings or producing hot water [7]. It reduces the amount of fuel needed for power generation, thus

¹ ¹ College of Energy and Power Engineering., Northeast electric Power University, Jilin 132000, Jilin, China

^a15940561053@163.com

^bneduzyl@163.com

Corresponding Author: Yunlong Zhou

Communication mailbox: neduzyl@163.com

reducing the peak demand on the power plant." fuel switching" is another deep peak shaving method, where the power plant is designed to switch between different types of fuels based on their availability and cost[8]. It minimises expenses and energy usage during times of peak demand by enabling the power plant to use less expensive fuels during off-peak hours [9].Deep peak shaving methods for thermal power generation units have been developed as a solution to address the high demands and increasing costs of electricity during peak hours[10]. These methods involve reducing or shifting the peak demands from the power grid to off-peak hours, thus reducing the overall system load and increasing its efficiency [11]. these methods have their challenges and issues, which must be carefully considered before implementation. One of the main issues with deep peak shaving methods is the high capital cost required for their implementation [12]. These methods typically involve upgrading the existing power generation units, which can be expensive and may require a significant investment [13]. It can also be challenging to find the right technology that is cost-effective and can effectively reduce peak demands while maintaining the reliability and stability of the power grid [14]. This cost may also be passed on to consumers, resulting in higher electricity bills. Another concern is the potential impact on the power generation units' operational efficiency and reliability. Deep peak shaving methods can put additional stress on power plants and their equipment, leading to increased wear and tear, maintenance costs, and potential outages [15]. It can negatively affect the overall performance of the power generation unit, leading to a decrease in its lifespan and efficiency. The following constitutes the research's primary contribution:

- Higher efficiency and lower costs: By maximising resource utilisation and minimising waste, deep peak shaving techniques for thermal power generating units dramatically raise power generation efficiency. Power generation firms benefit greatly from it, and customers may see a decrease in electricity prices as a result.
- Flexibility and grid stability: Thermal power production units can adapt more effectively to changes in the supply and demand for energy by using deep peak shaving techniques. It lessens the need for extra backup power sources, which can be expensive and ineffective, and contributes to grid stability.
- Environmental benefits: By reducing the need for fossil fuels to generate electricity, deep peak shaving techniques have a positive effect on the environment by lowering greenhouse gas emissions. Given the effects of climate change and mounting pressure to decarbonise the energy sector, it is imperative.

The remaining part of the research has the following chapters. Chapter 2 describes the recent works related to the research. Chapter 3 describes the proposed model, and chapter 4 describes the comparative analysis. Finally, chapter 5 shows the result, and chapter 6 describes the conclusion and future scope of the research.

2. Related Words

Fu C. et al. [16] have talked about integrating nuclear power into a power system while decreasing carbon emissions using the low-carbon constraint-oriented peak-shaving optimization method. It optimizes nuclear plant power output in accordance with economic and environmental limitations in an effort to balance the erratic supply and demand for electricity. Yang C. et al. [17] claim that during peak shaving, when power demand is highest, transient processes take place in the 300 MW coal-fired power unit. Heat rate, efficiency, and emissions are just a few of the variables that performance analysis looks at during these processes to ensure optimal performance and a steady supply of power. Day-Ahead and Intraday Two-Stage Optimal Dispatch has been studied by Zou, Y., et al. [18] as a means of efficiently managing the operation of carbon capture power plants and virtual energy storage. It includes two rounds of optimization for improved management and efficiency, as well as peak shaving, which aids in balancing the energy supply and demand. The difficulties in incorporating renewable energy sources into the electrical grid are addressed by this method.Sarmas, E. et al.'s research [19] focused on machine learning (ML)-based energy management algorithms, which maximize the energy usage of water pumping systems on small islands through machine learning techniques. These algorithms make it possible to use energy more effectively and to lower peak energy demand, which eventually saves money and improves sustainability in these isolated settlements. The technique of employing an electric heat pump and thermal energy storage in a combined heat and power plant to manage the high demand for energy during peak hours is known as "heat-power peak shaving," according to Wang H. et al. [20]. By storing excess electricity

and using it during times of high demand, this gadget helps accommodate wind power by reducing the need for conventional power sources. The Multi-Alliance Market Subject Auxiliary Peak Shaving Strategy for New Energy Consumption, a cooperative strategy among numerous allied organizations to maximize the consumption of new energy sources, has been discussed by Wu, Z., et al. [21]. Its goals are to guarantee more sustainable and efficient energy use and to lower peak demand during times of high use. Dai F. et al. [22] have investigated the use of master-enforced person game-based optimal scheduling as a decision-making method for energy management in a community with several providers and consumers. It looks at ways to encourage a decrease in peak energy use and uses carbon trading ladders to achieve this. It makes the community's shift to sustainable and efficient energy use easier. Li-ion batteries are increasingly being used in commercial buildings for peak shaving, price arbitrage, and solar self-consumption, according to Campana, P. E. et al. [23]. These batteries' financial sustainability and performance are evaluated by a Monte Carlo simulation. This modeling approach takes into consideration a number of variables, including electricity prices, energy demand, and weather. The basic frequency control performance assessment for thermal power plants during deep peak shaving has been studied by Xu, P., et al. [24]. The capacity of the facilities to operate at reduced capacity while maintaining a constant grid frequency during periods of high demand is assessed in this evaluation. Ensuring a steady supply of electricity during periods of high demand is a critical component of power plant operations. The modeling and thermal economy study of the coupled system of compressed steam energy storage and the Rankine cycle have been covered by Zhou J. et al. [25]. Making a mathematical model of the system and analyzing its cost and thermal efficiency are necessary for this. It allows for more cost-effective and efficient thermal power plant system optimization. Yu, B., et al. [26] have addressed the factors influencing the adoption of renewable energy. These elements include public support and awareness, laws and incentives from the government, advancements in technology, and the expanding need for sustainable and clean energy sources. Renewable energy sources are essential to the significant decarbonization of the power sector because of their capacity to significantly reduce carbon emissions and pave the way for achieving carbon peak targets. The Economic Dispatch of Wind-Solar-Photothermal Joint Power System with Green Certificate Trading and Peak Shaving Services has been examined by Fu G. et al. [27] as a management strategy for maximising the use of renewable energy sources while simultaneously offering extra services like peak demand reduction and green certificate sales. The objective of this strategy is to advance efficiency and sustainability in the energy industry. The Clearing Price Prediction Model, described by Liu, D., et al. [28], forecasts the clearing price of power peak shaving auxiliary services through the application of parallel deep learning techniques. It forecasts the ideal price that would balance supply and demand, guaranteeing an economical and efficient use of power, by examining past data and current market conditions. Power providers and consumers can improve their decision-making and operational efficiency with the aid of this approach. The Multi-type Peak Shaving Resource Coordination Optimisation Method is a technique that optimises the usage of different resources to lower peak power demand while taking into account variations in carbon emissions. Ni, B., et al. [29] have discussed this method. It attempts to manage energy resources effectively during peak hours while minimising the negative effects on the environment. This strategy helps develop a more sustainable and effective peak shaving approach by accounting for the variations in carbon emissions among various resource types. Hu, Y., et al. [30] have talked about The effect of rising renewable energy consumption on the demand side of the market is taken into consideration by the renewable portfolio standards value allocation model. It makes sure that the value of renewable energy is distributed fairly among all market participants by taking into account how this use impacts the value of renewable energy overall.

Table.1: Comprehensive Analysis

Author	Year	Advantage	Limitation
Fu, C., et, al. [16]	2022	Optimizing power generation schedules can reduce carbon emissions and increase efficiency, leading to more sustainable energy production.	Complexities in predicting nuclear power plant output due to weather conditions and unplanned maintenance may affect accuracy of peak shaving.

Yang, C., et, al. [17]	2023	Better understanding of power unit behaviour during peak shaving can improve efficiency and reliability of power generation.	Inaccurate assumptions or data may affect the accuracy of results and impact the effectiveness of the peak shaving strategy.
Zou, Y., et, al. [18]	2024	Improved cost-effectiveness and reliability of the power system due to optimized scheduling and utilization of carbon capture and energy storage resources.	Possible overestimation of the effectiveness of peak shaving due to uncertain market conditions and volatility.
Sarmas, E., et, al. [19]	2022	More accurate prediction of peak demand allows for more efficient energy usage, resulting in cost savings for small-scale islands.	Lack of predictability in changing environmental conditions may result in less accurate predictions and ineffective energy management strategies.
Wang, H., et, al. [20]	2023	Improved energy efficiency and reduced energy costs due to better utilization and balancing of renewable and thermal energy sources.	Unreliable supply due to variable weather conditions affecting both wind power output and heat demand.
Wu, Z., et, al. [21]	2023	Improved stability and reliability of the electricity grid due to efficient coordination and redistribution of energy resources.	Possible lack of coordination and cooperation between different alliances, leading to inconsistent or ineffective peak shaving measures.
Dai, F., et, al. [22]	2023	The advantage is promoting energy conservation and reduction of carbon emissions within the community through incentivized behaviour.	One limitation is that it relies heavily on the accuracy of data input and may not account for unforeseen changes or events.
Campana, P. E., et, al. [23]	2021	The ability to discharge and recharge quickly allows for efficient management of varying energy demands in commercial buildings.	Limited cycle life and decreased performance over time can reduce effectiveness and savings potential of these applications.
Xu, P., et, al. [24]	2022	It ensures a consistent and reliable response to sudden and large changes in system frequency, maintaining grid stability.	Difficulty in accurately measuring and attributing the impact of other factors, such as weather and demand patterns, on plant performance during deep peak shaving.
Zhou, J., et, al. [25]	2024	lower environmental effect and financial savings due to increased energy efficiency.	One limitation is that the analysis does not take into account potential external factors such as weather conditions or market fluctuations.
Yu, B., et, al. [26]	2023	Reduced greenhouse gas emissions	The high initial cost of renewable

		can accelerate the decarbonisation process and help reach carbon peak quicker for a more sustainable future.	energy technology may hinder its widespread adoption and acceleration of decarbonisation efforts.
Fu, G., et. al. [27]	2023	Enhanced renewable energy integration and cost-effectiveness through optimized dispatch, trading, and peak shaving strategies.	One limitation could be the complexity of managing three different renewable energy sources and incorporating green certificate trading and peak shaving services into one system.
Liu, D., et. al. [28]	2022	The model can effectively and accurately predict the clearing price for power peak shaving, enabling efficient and cost-effective energy management decisions.	One possible limitation of the Clearing Price Prediction Model is that it may not accurately account for unexpected events or changes in market conditions.
Ni, B., et. al. [29]	2023	Reduced carbon emissions due to more efficient use of multiple resources, leading to a more sustainable energy system.	One limitation is that it does not account for individual peak load profiles of different types of resources.
Hu, Y., et. al. [30]	2022	increased energy efficiency that lowers costs and has a smaller environmental effect.	Difficulty in accurately measuring and quantifying the impact of individual consumers' renewable energy consumption on overall demand.

- Limited flexibility in operation: Deep peak shaving methods often need more flexibility in operation due to their reliance on specific conditions or parameters. It can lead to difficulties in adapting to changing demand patterns and fluctuating energy prices.
- Impact on unit efficiency: Deep peak shaving methods typically involve operating thermal power generation units at lower output levels than their maximum capacity. It can adversely affect the efficiency and performance of the units, resulting in reduced overall energy production.
- System reliability and stability concerns: Implementation of deep peak shaving methods can pose challenges in maintaining system reliability and stability, particularly during peak demand periods. The sudden reduction in output from thermal power generation units can create imbalances in the grid and increase the risk of blackouts or load shedding.

The improved energy consumption framework incorporates several technical advancements to address the pressing issue of energy consumption. One of the critical novelties is the integration of advanced sensors and devices that gather real-time data on energy usage. This data is then processed using sophisticated algorithms to detect patterns and identify areas of high consumption. Another significant technological improvement is the use of smart home automation systems that can efficiently manage and regulate energy usage based on user preferences and habits. The framework incorporates renewable energy sources, such as solar panels and wind turbines, to lessen reliance on traditional energy sources. Overall, these advancements significantly enhance the accuracy and efficiency of energy consumption management, allowing for more effective and sustainable energy usage in homes and buildings.

2. Proposed system

A. Construction diagram

➤ Heat supply unit

A Heat supply unit, also known as a heat source or heat supply system, is a device responsible for providing heat to a building or a specific space within a building. It is an essential component of any heating system and plays a crucial role in maintaining the desired temperature and comfort level in a building. The main operation of a Heat supply unit involves using a heat source, which can be either a furnace, boiler, heat pump, solar panels, or a combination of these. The heat source generates heat by converting a fuel source (such as gas, oil, electricity) or solar energy into heat energy. The heat generated by the heat source is then transferred to a heat distribution system, which can be pipes, ducts, or radiators.

Function fitting can be used to determine the coal consumption characteristic characteristics of thermal power plants.

$$R_1 = (p_i A_{gi,t}^2 + q_i A_{gi,t} + r_i) R_{coal} \quad (1)$$

where R_1 , which stands for the thermal power unit's actual output power at any given time, is the cost of coal consumption.

y. When different thermal power units have differing capabilities, the rotor shaft's life loss is made worse. This study uses the Manson–Coffin formula as a guide to determine the lifecycle cost of the rotor shaft.

$$R_2 = \frac{\lambda R_{unit}}{2N_f(A_{gi,t})} \quad (2)$$

$$R_3 = B_{oil} D_{oil} \quad (3)$$

$$R(A_{gi,t}) = \begin{cases} R_1 & A_{\min} \leq A_{gi,t} \leq A_{\max} \\ R_1 + R_2 & A_p \leq A_{gi,t} \leq A_{\min} \\ R_1 + R_2 + R_3 & A_q \leq A_{gi,t} \leq A_a \end{cases} \quad (4)$$

The heat distribution system carries the heat to different parts of the building where it is needed. The heat supply unit also has a control system that regulates the temperature and ensures that the heat is delivered efficiently to different building parts. Depending on the unit type, this control system can be manual or automated. In a manual control system, the user can adjust the temperature and manually turn the unit on or off. On the other hand, a computerized control system uses sensors and thermostats to monitor the temperature and adjust the heat output accordingly.

➤ Heat network system

A heat network system is a centralized heating and hot water distribution system that supplies multiple buildings or homes with heat from a single energy source. This energy source can be a centralized boiler, a combined heat and power (CHP) plant, or a renewable energy source such as biomass or solar thermal. The operations of a heat network system involve three main components - the energy source, the distribution network, and the building connections. The energy source is the heart of the heat network system and is responsible for generating heat that will be distributed to the buildings. The construction diagram has shown in the following fig.1

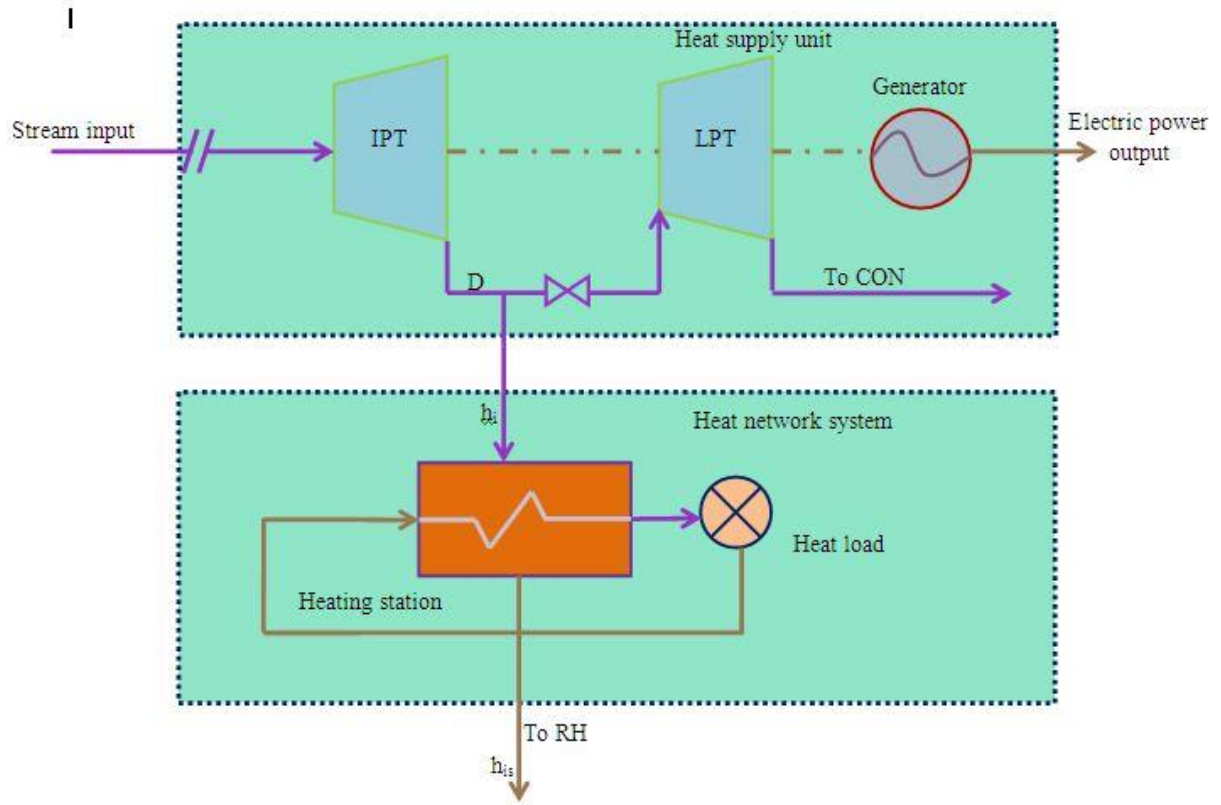

Fig 1: Construction diagram

The energy source's type and size depend on the network's heat demand and the availability of local resources. For example, if the network serves many buildings, a CHP plant may be used to meet the high energy demand. The energy source operates by burning fuels or utilizing renewable resources to produce heat. Once the heat is produced, it is transported through a network of pipes to the buildings connected to the heat network system.

Equations, using the second method's quadratic function to simulate carbon emissions during the peak shaving procedure, can be used to express the process in this study.

$$R_{emi.g} = R_{emi.g} + R_{emi.q} \tag{5}$$

$$\begin{cases} R_{emi.g} = \sum_{t=1}^T \sum_{i=1}^N \left[\alpha_i (A_{gi,t})^2 + \beta_i A_{gi,t} + \lambda_i \right] \\ R_{emi.q} = H \sum_{t=1}^T A_{buy,t} \end{cases} \tag{6}$$

Variable working conditions cause irreversible changes in other metallic components of the unit in addition to shortening the rotor shaft's lifespan. These changes result in on-off expenses and have an impact on the unit's overall service life. Equations can be used to represent the cost of a unit participating in on-off peak shaving.

$$R_4 = K_{gi,t} (1 - K_{gi,t-1}) R_{iup} + K_{gi,t-1} (1 - K_{gi,t}) R_{idown} \tag{7}$$

$$K_{gi,t} = W_{gi,t} + U_{gi,t} + V_{gi,t} \tag{8}$$

This distribution network comprises insulated pipes that can withstand high pressures and temperatures. The size and layout of the network depend on the heat demand and the location of the buildings. The network is designed to ensure that the heat reaches all buildings at a consistent and efficient temperature.

➤ **Heating station**

A heating station is designed to generate heat and provide it to a surrounding area or system. This process involves several critical operations, which work together to produce and distribute heat effectively. The heating station must have a source of fuel, such as natural gas, oil, or coal. This fuel is usually stored in large tanks or silos within the station. When needed, the fuel is fed into a combustion chamber, which is burned at high temperatures. The heat generated by this combustion process is then transferred to a heat exchanger, essentially a series of pipes or tubes exposed to the heat. These pipes or tubes are filled with a fluid, such as water or steam, which absorbs the heat and carries it away from the combustion chamber.

$$\min \left\{ R_{stage1} + \max \left(a^{T+1} \min R'_{stage2} \right) \right\} \quad (9)$$

Operating costs and power purchase costs are included in the sub-function

$$R_{stage1} = D_{buy} A_{buy} \quad (10)$$

$$R'_{stage2} = R_{g1} + R_{g2} + R_{g3} - R_{GP} + R_{ES} + R_{cur} \quad (11)$$

R_{g1} , R_{g2} , and R_{g3} , respectively, represent the power generation cost of thermal power unit 1, unit 2, and unit 3, R_{GP} represents the compensation for the unit involved in deep peak regulation, Cost of power generation for the thermal power unit

$$\left\{ \begin{array}{l} R_{g1} = R_1 + R_4 \\ R_{g2} = R_1 + R_4 \\ R_{g3} = R_1 + R_2 + R_3 + R_4 \end{array} \right\} \quad (12)$$

$$R_{GA} = A_{gi.t} D_b \quad (13)$$

The heated fluid then passes through a network of pipes, known as a distribution system, which carries it to the areas or systems that require heating. This distribution system can comprise various components, such as pumps, valves, and regulators, which work together to control the flow and temperature of the fluid. In some cases, the heating station may also have a heat storage system, which allows excess heat to be stored for later use. It can be particularly useful during periods of high demand, when the heating station may need help to keep up with the immediate heating needs of the surrounding area.

➤ **Heat load**

Heat load refers to the amount of heat transferred into or out of a system. It is an essential concept in thermodynamics and is critical in many industrial, technological, and natural processes. The term "heat load" can refer to both the amount of heat transferred and the heat transfer rate, depending on the context in which it is used. The operations of heat load involve the movement of thermal energy, which is the energy associated with the motion of molecules within a substance. Conduction, convection, and radiation are a few of the ways that this energy can move from one system to another. Convection is the movement of molecules in a fluid as a result of temperature differences, whereas conduction is the transmission of heat by direct contact between two things.

$$R_{ES} = \delta_{ES} \sum_{t=1}^{24} (A_{ES.cha}^t + A_{ES.dis}^t) \quad (14)$$

$$R_{cur} = \delta_{cur} \sum_{t=1}^{24} (A_{pv.cur} + A_{wd.cur}) \quad (15)$$

Radiation, conversely, consists of the transfer of heat through electromagnetic waves. One key factor affecting heat load is the temperature difference between the two systems. The more significant the temperature difference, the greater the heat load. For example, heat load is critical in refrigeration and air conditioning systems, where thermal energy is transferred from a warmer environment to a cooler one. In this case, the heat load is determined by factors such as the temperature difference between the indoor and outdoor environments, the insulation of the building, and the efficiency of the cooling system.

➤ **Electric power**

Electrical energy is created and sent to different systems and devices using electric power. First, mechanical energy from a main energy source—such as coal, natural gas, or wind—must be converted into electric power. Generators are then used to transform this mechanical energy into electrical energy. Electrical energy is transmitted via a convoluted network of transformers and power lines when it is generated. The extensive system of interconnected transmission lines that carries electricity from power plants to residences, commercial buildings and other establishments is known as the electric power grid. This grid is made up of low-voltage distribution lines that supply electricity to specific users and high-voltage transmission lines that transport massive amounts of electricity over great distances.

System constraints,

$$A_{g1} + A_{g2} + A_{g3} + A_{pv} + A_{wd} + A_{ES.dis} + A_{buy} = A_L + A_{ES.dis} \quad (16)$$

$$A_{gi.min} \leq A_{gi} \leq A_{gi.max} \quad (17)$$

$$A_{gi.down} \leq A_{gi}^t - A_{gi}^{t-1} \leq A_{gi.up} \quad (18)$$

The efficient transmission of electric power relies on transformers, which convert voltage levels for more effortless transfer. High-voltage transmission lines carry electricity at hundreds or even millions of volts, while low-voltage distribution lines typically carry electricity at around 120 volts. The amount of power that can be supplied to a specific item is determined by current, which is the flow of electricity and is measured in amps.

B. Functional working model

➤ **HBT**

HBT, "Heterojunction Bipolar Transistor", is a semiconductor device that amplifies electrical signals. Emitter, base, and collector are the three layers made up of semiconductor materials that have been doped differently. The base layer is sandwiched between the emitter and collector layers in this sandwich-like arrangement of layers. An understanding of HBT can be gained by examining the distinct functions of each layer. Because of the heavy impurity doping in the emitter layer, there are a lot of free electrons.

Unit on–off constraint,

$$\begin{cases} K_{gi,\tau} \geq \tau (K_{g1,t} - K_{g1,t-1}) & \tau = t, t+1, t+2, \dots, t + T_{g1,\min}^{on} - 1 \\ 1 - K_{gi,\tau} \geq \tau (K_{g1,t-1} - K_{g1,t}) & \tau = t, t+1, t+2, \dots, t + T_{g1,\min}^{off} - 1 \end{cases} \quad (19)$$

where τ denotes the min continuous on-off time for units.

Equipment for storing electric energy has limitations.

$$\begin{cases} A_{ES}^{\min} \leq A_{ES}^t \leq A_{ES}^{\max} \\ A_{ES,cha}^{\min} \leq A_{ES,cha}^t \leq \alpha_{H,cha} A_{ES,cha}^{\max} \\ A_{ES,dis}^{\min} \leq A_{ES,dis}^t \leq \alpha_{H,dis} A_{ES,dis}^{\max} \\ \alpha_{H,cha} + \alpha_{H,dis} \leq 1 \end{cases} \quad (20)$$

Electrons from the emitter are injected into the base layer when a voltage is provided to the base-emitter junction. It produces the quasi-neutral region, an area of surplus electrons in the base layer. A region of extra holes is created by the light doping of the collector layer. A current flows from the collector to the base as a result of the injected electrons recombining with the holes in the collector layer as they diffuse across the quasi-neutral area. The voltage provided to the base-emitter junction controls this current, which can be amplified depending on how the device is made. Because of its mild doping, the base layer serves as a barrier for the injected electrons, lowering the rate at which they recombine with the holes in the collector layer.

➤ **IPT**

IPT (Internet Protocol Television) is a technology that allows the delivery of TV channels, movies, and other video content over the Internet Protocol (IP) network infrastructure. It works by converting traditional television signals into data that can be transmitted through internet protocol packets. The first step in IPTV is encoding video content into a digital format compatible with IP transmission. This process involves compressing the video data to reduce its size and make it easier to transmit over the Internet. The functional block diagram has shown in the following fig.2

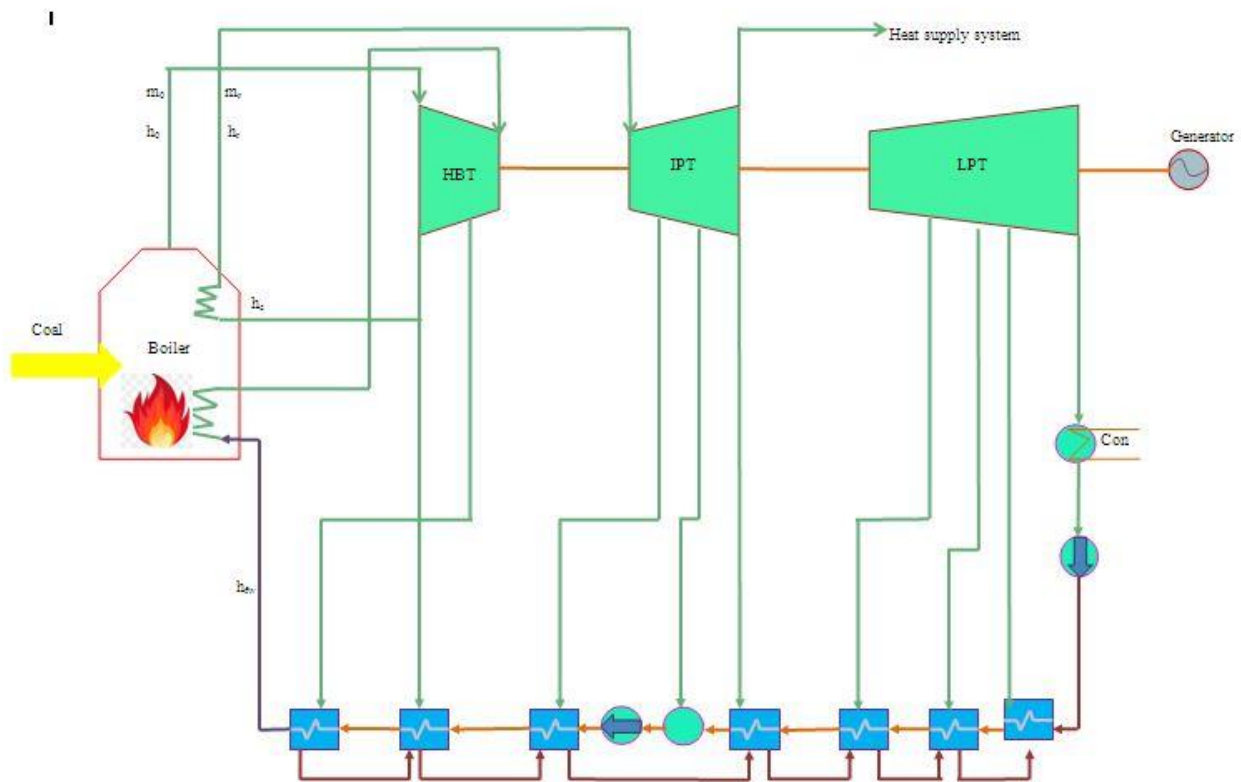

Fig 2: Functional block diagram

MPEG-2, MPEG-4, and H.264 are the encoding standards that are most frequently used for IPTV. After being encoded, the video content is sent across the Internet, LANs, and WANs (wide area networks) or local area networks (LANs). Small packets containing the video data are divided up and delivered across switches and routers to the specified destination address. The IPTV service provider installs a middleware programme at the recipient end to act as a conduit between the user and the service. Because it controls the communication between the user's set-top box and the service provider's server, this middleware is essential. It also manages additional interactive elements including time-shifted television and video on demand (VOD), as well as interactions with the electronic programme guide (EPG).

➤ **LPT**

The Line Printer Terminal (LPT), a parallel port, is a hardware interface for connecting a computer to a printer. It is mainly used for transferring print data from the computer to the printer, allowing the user to print documents and other materials. LPT is an essential component in older computer systems, but it is still used in some modern systems for its high data transfer rate. The operations of LPT can be divided into three main stages: initialization, data transfer, and handshaking.

$$\begin{cases} 0 \leq A_{wd}^t \leq A_{wd}^{sen} \\ 0 \leq A_{wd.cur}^t \leq A_{wd}^{sen} \\ A_{wd}^t + A_{wd.cur}^t = A_{wd}^{sen} \end{cases} \quad (21)$$

where A_{wd}^{sen} denotes the predicted value of wind power output.

$$\begin{cases} 0 \leq A_{pv}^t \leq A_{pv}^{sen} \\ 0 \leq A_{pv.cur}^t \leq A_{pv}^{sen} \\ A_{pv}^t + A_{pv.cur}^t = A_{pv}^{sen} \end{cases} \quad (22)$$

where A_{pv}^{sen} denotes the predicted value of photovoltaic output.

$$\Omega = \begin{cases} a_i \geq 0, i = 1, 2, \dots, v \\ \sum_{i=1}^v a_i = 1 \\ Ac \left\{ \sum_{i=1}^v |a_i - a_i^0| \leq \theta_1 \right\} \geq \alpha_1 \\ Ac \left\{ \max |a_i - a_i^0| \leq \theta_\infty \right\} \geq \alpha_1 \end{cases} \quad (23)$$

The initialization stage begins with the computer requesting the LPT to initiate communication. It is usually done through a command or instruction from the printer driver. The LPT then checks for any errors and prepares itself for data transfer. In the data transfer stage, the computer sends the print data in binary numbers known as bits. These bits are converted into electrical signals and sent to the printer through the LPT's parallel channels. LPT uses a parallel communication method, meaning it can transmit multiple bits of data simultaneously, making it faster than serial communication methods. The handshaking stage is crucial in ensuring the print data is communicated accurately and without errors. It involves a series of signals and messages between the computer and the printer, known as handshaking signals. These signals synchronize data transmission, indicate the printer's status, and detect any errors during the transfer.

➤ **Heat supply system**

A heat supply system delivers heat to a designated space or building, providing occupants with a comfortable and liveable environment. This system is often used in residential, commercial, and industrial settings, and it works through a series of operations involving heat production and distribution. The first step in the operation of a heat supply system is the production of heat. It is typically done through a heating source, such as a furnace, boiler, or heat pump, which converts fuel or electricity into heat energy.

the following confidence levels $\{a_v\}$ are satisfied,

$$\begin{cases} Ac \left\{ \sum_{i=1}^v |a_i - a_i^0| \leq \theta_1 \right\} \geq 1 - 2Ve^{-\frac{2X\theta_1}{v}} \\ Ac \left\{ \max |a_i - a_i^0| \leq \theta_\infty \right\} \geq 1 - 2Ve^{-2X\theta_\infty} \end{cases} \quad (24)$$

$$\begin{cases} \theta_1 = \frac{V}{2X} \ln \frac{2V}{1-\alpha} \\ \theta_\infty = \frac{1}{2X} \ln \frac{2V}{1-\alpha_\infty} \end{cases} \quad (25)$$

Update probability scenario values using Equations (13) and (15) and F1 in Equation (9),

$$\left\{ \begin{array}{l} LB = \{ \min(R_{stage1} + \eta), LB \} \\ UB = \{ R_{stage1} + \max(a^{T+1} \min R'_{stage2}), UB \} \\ \eta \geq a^T R'_{stage2} \\ a^T = a^0 \quad \text{if } T = 1 \end{array} \right. \quad (26)$$

The heat is then transferred to a heat distribution medium, such as water, steam, or air. In a water-based system, the heated water is pumped through a network of pipes to different building areas, releasing heat through radiators, baseboards, or underfloor heating systems. In a steam-based system, the heated steam is distributed through pipes and released through radiators or other heat exchange devices. In an air-based system, the heated air is blown through ducts and released through vents in the walls, floors, or ceilings. The heat distribution is controlled by a thermostat, which senses the temperature in the designated space and signals the heating source to turn on or off as needed. More advanced systems may also use zoning controls, allowing different building areas to be heated or cooled independently.

➤ **Boiler**

A boiler is a closed vessel used to heat water or produce steam. It transfers heat from a fuel source, such as coal or natural gas, to the water inside the boiler. The heated water is circulated through pipes to various parts of a building or facility, providing hot water and steam as needed. The type of boiler, its size, and the type of fuel used all play a role in determining its operations. The first step in the operation of a boiler is the process of ignition. It starts the combustion process, where the fuel and air mixture is ignited and begins to burn. The resulting heat is then transferred to the water in the boiler, either directly or indirectly, through tubes or heat exchangers. As the water is heated, it begins to expand and rise to the top of the boiler, where it is circulated through pipes to various areas of the building.

The revised scenario probability from the previous iteration is used in the next iterations. Precision is ensured by the residual (re) convergent to the minimal value by iterative refining.

$$re = |(UB - LB) / UB| \quad (27)$$

$$\eta = y(Z, AM, T_{out}) \quad (28)$$

This method is accurate enough to do a preliminary analysis of the impacts of installing a BESS.

$$\left\{ \begin{array}{l} SOC_{BESS}(t) = SOC_{BESS}(t-1) + \eta_{re} \frac{A_{BESS, ch}(t) \cdot \Delta t}{R_{BESS}} (charge) \\ SOC_{BESS}(t) = SOC_{BESS}(t-1) - \frac{A_{BESS, dis}(t) \cdot \Delta t}{R_{BESS}} (charge) \end{array} \right. \quad (29)$$

The water's movement is aided by pumps or natural convection, depending on the type of boiler. In steam boilers, the heated water is converted into steam, which then travels through pipes to heat different building areas or power machinery. The boiler's control system plays a critical role in its operation. It regulates the fuel and air mixture, ensuring the flame stays at the desired temperature for efficient combustion. It also maintains the water levels and pressure within the boiler to prevent any damage or explosions.

➤ **Coal**

Coal is a fossil fuel formed over millions of years by compressing organic materials such as plant matter and sediments. It is a complex mixture of carbon compounds and minerals, mainly carbon, hydrogen, oxygen, nitrogen, and sulphur. Coal is primarily used for electricity production but has other industrial applications such as heat, steel, and chemical production. The process of coal formation begins with dead plants and animals being buried under layers of earth and sediment. Over time, the weight of these layers compresses the organic materials, causing them to undergo chemical and physical changes.

$$P = MO \times RY = (mo, ry) : mo \in MO, ry \in RY \quad (30)$$

The first stage of coal formation is the creation of peat, a soft and crumbly mixture of partially decomposed organic matter. As the layers of sediment and earth continue to build up, the peat becomes more compact and turns into lignite, a low-grade coal. As the layers of sediment increase, the heat and pressure intensify, causing the lignite to transform into bituminous coal, the most abundant type of coal. Bituminous coal is used extensively for electricity production due to its high carbon and relatively low sulphur content. Further compression and heat can turn bituminous coal into anthracite, the highest grade of coal with the highest carbon content. Coal extraction involves drilling into the ground to reach the coal deposits.

C. Operating principles

➤ **Inter-plant load distribution**

Inter-plant load distribution is a complex process involving allocating power and energy among multiple plant sites. This operation is crucial for ensuring the efficient use of resources and maintaining a stable power supply to meet customers' demands. It involves sharing the load or workload among different plants to avoid overwhelming one particular plant. The operation of inter-plant load distribution starts with collecting and analysing data from various sources. These include real-time demand data, weather patterns, and historical load patterns. This data is then input into sophisticated algorithms and mathematical models, which are used to forecast future energy demand. Based on these forecasts, the load distribution system determines the optimal energy distribution among the plants.

$$C = -(\delta \times C_E + \beta \times C_T) \quad (31)$$

$$C_E = r_E \times (X_{CHILLER} + X_{PUMP} + X_{LOAD}) \quad (32)$$

$$C_T = \begin{cases} (|DA_{INT} - T_{INT}|)^3 & \text{if } T_{LOW} - 2 < T_{LOW} \text{ and } T_{UPP} < T_{INT} \leq T_{UPP} + 2 \\ 50 & \text{if } T_{INT} < T_{LOW} - 2 \text{ and } T_{INT} > T_{UPP} + 2 \\ 0 & \text{if } T_{LOW} \leq T_{INT} \leq T_{UPP} \end{cases} \quad (33)$$

This decision-making process considers various factors, such as the capacity of each plant, the availability of resources, and the geographical location of the plants. By balancing these factors, the system aims to achieve optimal plant load distribution. Once the load distribution plan is finalized, it is implemented using specialized control systems. These systems facilitate communication and coordination between the different plants, ensuring that the load is shared according to the determined plan. They also monitor and adjust the load distribution based on changes in demand or unforeseen events, such as equipment failures. In addition to load sharing, the inter-plant load distribution system also manages energy transfer between plants.

➤ **Inter-plant power distribution**

Inter-plant power distribution is a complex network of processes that involves the transfer of electrical energy from power plants to various industry plants, such as factories and manufacturing facilities. This system is crucial for maintaining a stable and reliable power supply to support the production and operation of these plants. The first step in inter-plant power distribution is electricity generation at power plants. These plants use various fuel sources, such as coal, natural gas, or nuclear energy, to produce electricity through electromechanical energy conversion.

$$C_{inductive} = -(\delta \times C_X + \beta \times C_T + \theta \times C_a) \quad (34)$$

$$C_{cost,source} = r_E \times (C_{CHILLER} + C_{PUMP}) \quad (35)$$

$$T_{viol} = \sum_{i=0}^N T_{viol,i} \quad (36)$$

$$X_{cost} = r_E \times (X_{CHILLER} + X_{PUMP} + X_{LOAD}) - I_E \quad (37)$$

The time step size t_s is absorbed into the price coefficients to make equations simple.

This energy is then converted into high-voltage alternating current (AC) by generators before being transmitted through high-voltage transmission lines. Once the electricity reaches the substation, it is released to a lower voltage suitable for industrial use. It is achieved through transformers, which reduce the voltage to levels ranging from 10 kV to 138 kV. The substation also serves as a switching point, allowing power to be redirected to different areas. The electricity is sent through distribution lines to the plants from the substation. These lines are typically made of aluminium or copper and designed to carry high currents safely without significant losses. Distribution lines may vary in length and size depending on the distance and power requirements of the plants they supply. The electricity is again transformed to a lower voltage at the receiving plant and distributed through an electrical switchgear system.

➤ **Set FPR and VPR**

FPR (False Positive Rate) and VPR (Verification Pass Rate) are two metrics that are used to evaluate the performance of a biometric authentication system. They are calculated based on the system's verification process outcomes, where a person's presented biometric data is compared to their enrolled template. The FPR is the percentage of times the system incorrectly identifies a non-authorized person as an authorized user. In other words, it measures how many “false alarms” occur, where the system incorrectly grants access to an individual who should not be granted access. It can happen for various reasons, such as poor-quality biometric data, spoof attacks, or inaccuracies in the system's matching algorithm.

$$\text{Total energy cost } B = B_{elect} + B_{peak} \quad (38)$$

$$B_{elect} = \alpha \sum_{t=1}^T \delta(t) \cdot t_s = \alpha \sum_{t=1}^T \delta(t) \quad (39)$$

$$B_{peak} = \beta \cdot \text{Max}_{t=1,2,\dots,T} [\overline{\delta(t)}] \quad (40)$$

The VPR is calculated by dividing the number of successful verifications by the total number of verification attempts. To improve the performance of a biometric authentication system, minimizing the FPR and maximizing the VPR is essential. It can be achieved through various techniques, such as improving the quality

of biometric data captured, using multiple biometric modalities, and implementing more advanced matching algorithms.

➤ **GA**

Genetic Algorithm (GA) is a heuristic search algorithm inspired by the principles of natural selection and genetics in biology. It is a computational approach that mimics the process of evolution and natural selection, which is the driving force behind the diversity and adaptation of species in the biological world. At the core of GA are three primary operations known as selection, crossover, and mutation. These operations are applied to a population of potential solutions to a problem, represented as strings of binary or real-valued values called chromosomes. GA aims to find the best solution or the fittest chromosome that satisfies the problem's requirements. The operational flow diagram has shown in the following fig.3

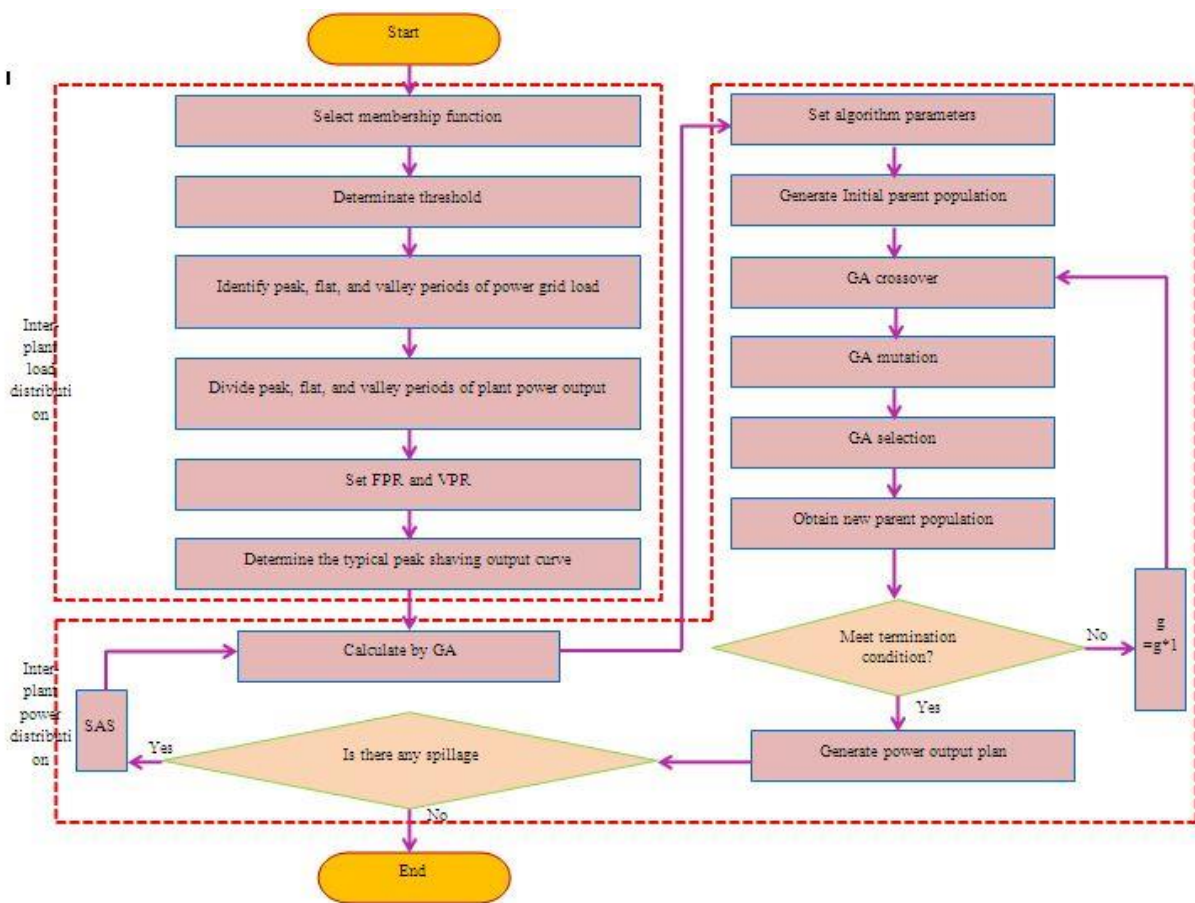

Fig 3: Operational flow diagram

The first operation, selection, is responsible for preserving the fittest chromosomes in the population and eliminating the weaker ones. It is done through fitness evaluation, where each chromosome is assigned a fitness value based on how well it satisfies the problem's requirements. The fittest chromosomes are more likely to be selected for the next generation, while the weaker ones have a lower chance or are removed entirely.

$$B = \alpha \sum_{t=1}^T \delta(t) + \beta \cdot \text{Max}_{t=1,2,\dots,T} [\delta(t)] \tag{41}$$

The second operation, crossover, is the process of combining selected chromosomes to create new offspring. It mimics the natural reproduction process, where the genetic material from two parents is combined to produce

offspring with a mix of their traits. In GA, crossover involves selecting a random point on the chromosomes and exchanging the genetic material between two parent chromosomes to create two new offspring.

➤ **Parent population**

Parent population refers to the entire group of individuals, things, or events that we are interested in studying. This population serves as the basis for statistical inference and is crucial in understanding the characteristics and behaviours of the group we are learning. To accurately describe and understand the parent population, we must delve into its operations, which involve complex and interconnected processes. The first essential operation of the parent population is its formation. It refers to how the population came to exist in its current state. It could be through natural selection, artificial selection, or other evolutionary processes. Understanding the formation of the population is crucial as it can provide insights into its genetic makeup and potential underlying patterns.

$$\delta(t)^{\min} \leq \delta(t) \leq \delta(t)^{\max}; t = 0, 15s, 30s, \dots \quad (42)$$

Next is the maintenance of the parent population. It involves the processes that keep the population in existence and functioning. Factors such as reproduction, environmental factors, and genetic variation all play a role in maintaining the population. Moreover, external factors such as disease outbreaks or natural disasters can also impact the maintenance of the population. The parent population also goes through growth and decline cycles, known as population dynamics. This operation considers the changes in the size and composition of the population over time. Various factors can affect population dynamics, such as competition for resources, predation, and environmental conditions. Understanding these fluctuations in the population is vital in predicting its future growth and potential risks.

➤ **Generate power output plan**

Creating a power output plan is a process that involves creating a plan for the production and distribution of electricity. This plan considers various factors such as demand, resource availability, and technical capabilities to ensure a reliable and efficient power supply. The first step in generating a power output plan is to assess the electricity demand. It involves analysing historical data and predictions to determine the expected power consumption for a specific period. This information is crucial in determining the required power output. The next step is to consider the resources available for power generation. It includes renewable sources such as solar, wind, hydro, and non-renewable sources such as coal, natural gas, and nuclear energy. The availability and capacity of each resource are evaluated to determine how much power can be generated from each source. The power output plan is formulated once the demand and resource assessment is complete.

$$\overline{\delta(t)^{\min}} \leq \overline{\delta(t)} \leq \overline{\delta(t)^{\max}} \quad (43)$$

In order to increase the utilization of clean energy, PS uses thermal power to supply residual load demand after wind energy, which is called the equivalent load P_{loadeq} , namely;

$$A_G = A_{loadeq} = A_{load} - A_{wind} \quad (44)$$

In the normal peaking phase, the peaking cost is the cost per generator of operating coal consumption, and it can be represented as the result of multiplying the amount of coal consumed by the price per unit of coal generator, as illustrated in the figure below:

$$R_{coal,i,t}(A_{G,i,t}) = (p_i A_{G,i,t}^2 + q_i A_{G,i,t} + r_i) a_{coal} \quad (45)$$

This plan specifies the sources and quantity of power generated to meet the demand. It considers each resource's different characteristics, such as their reliability, cost, and environmental impact. In addition to generation, the power output plan also includes how the electricity will be distributed to consumers. It includes planning for

transmission and distribution networks and ensuring their capacity is sufficient to handle the predicted power output. The power output plan also considers any potential risks and contingencies that may affect the production and distribution of power. These may include weather events, equipment failures, or unexpected changes in demand.

3. Result and Discussion

The performance of proposed method Reinforcement Learning for Energy Consumption Optimization (RLECO) have compared with Convex Optimization for Deep Peak Shaving (CODPS), Genetic Algorithm for Optimal Peak Shaving (GAOPS) and Ant Colony Optimization for Peak Shaving (ACOPS).

3.1 Signal-to-Interference-plus-Noise Ratio (SINR)

This measures the quality of the received signal by taking into account both the desired signal and the noise and interference present in the network. The higher the SINR, the better the overall signal quality and the more influential the filtering framework Table.2 shows the comparison of Signal-to-Interference-plus-Noise Ratio between existing and proposed models.

Table.2: Comparison of Signal-to-Interference-plus-Noise Ratio (in %)

No. of Images	CODPS	GAOPS	ACOPS	RLECO
100	63.30	44.87	55.18	72.01
200	61.56	43.29	53.76	70.72
300	59.22	41.09	52.50	69.71
400	58.41	39.46	50.51	68.82
500	56.12	38.32	48.04	68.45

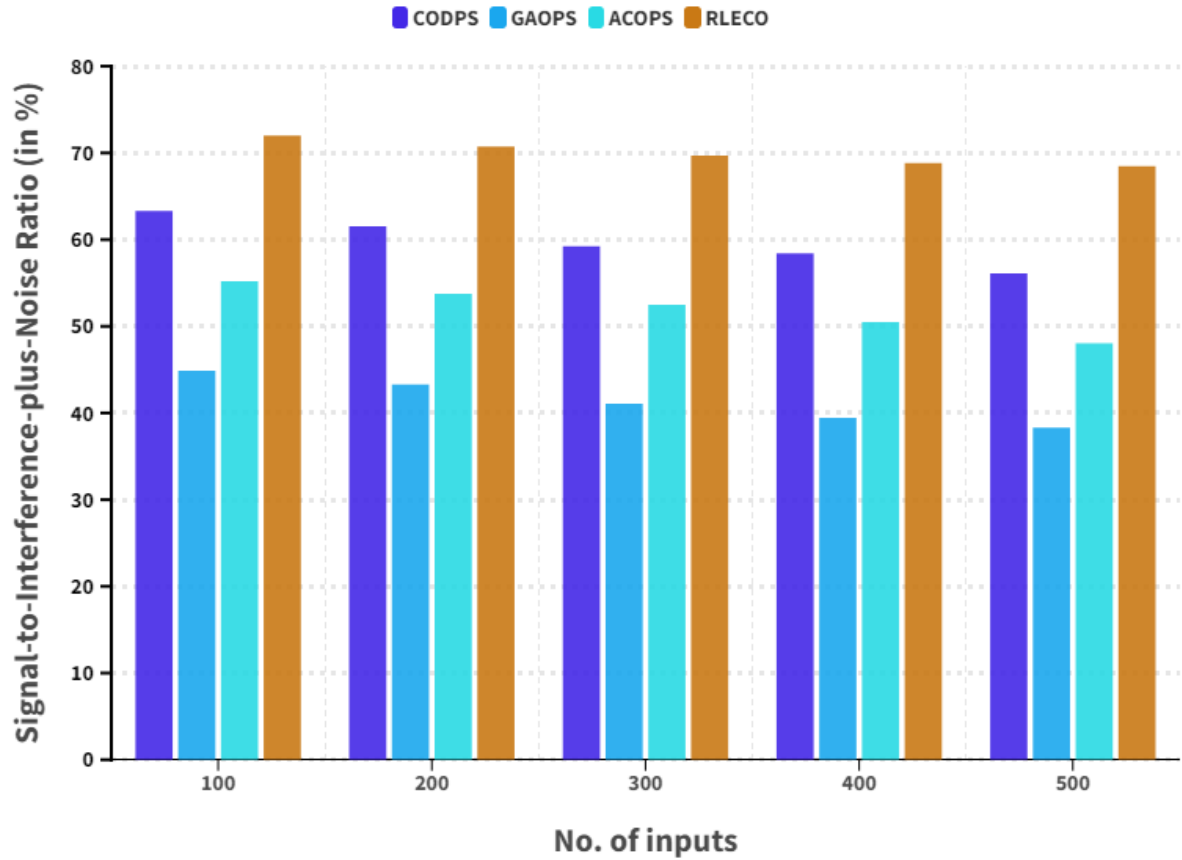

Fig.4: Comparison of Signal-to-Interference-plus-Noise Ratio

Fig. 4 shows the comparison of Signal-to-Interference-plus-Noise Ratio . In a computation cycle, the existing CODPS obtained 56.12 %, GAOPS obtained 38.32 %, ACOPS reached 48.04 % Signal-to-Interference-plus-Noise Ratio. The proposed RLECO obtained 68.45 % Signal-to-Interference-plus-Noise Ratio.

3.2 Filtering Accuracy:

This parameter measures the ability of the framework to accurately identify and remove interference in the network without affecting the desired signals. A high filtering accuracy is crucial for effectively reducing interference and improving network performance Table.3 shows the comparison of Filtering Accuracy between existing and proposed models.

Table.3: Comparison of Filtering Accuracy (in %)

No. of Images	CODPS	GAOPS	ACOPS	RLECO
100	66.30	48.87	59.18	76.01
200	64.56	47.29	57.76	74.72
300	62.22	45.09	56.50	73.71
400	61.41	43.46	54.51	72.82
500	59.12	42.32	52.04	72.45

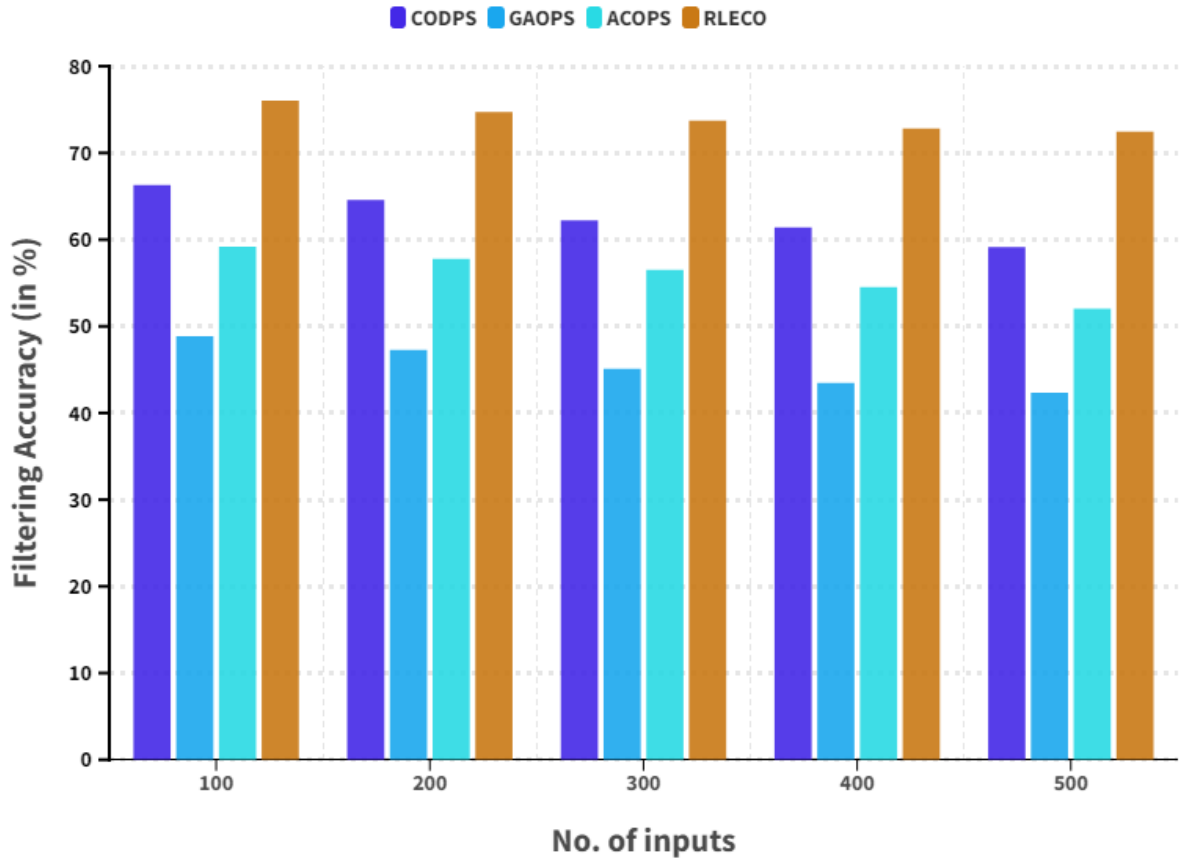

Fig.5: Comparison of Filtering Accuracy

Fig. 5 shows the comparison of Filtering Accuracy. In a computation cycle, the existing CODPS obtained 59.12%, GAOPS obtained 42.32%, ACOPS reached 52.04 % Filtering Accuracy. The proposed RLECO obtained 72.45 % Filtering Accuracy.

3.3 Computational Complexity:

As 6G networks are expected to handle massive amounts of data and connected devices, the filtering framework must have low computational complexity in order to process and filter out interference in real time efficiently. Table.4 shows the comparison of Computational Complexity between existing and proposed models.

Table.4: Comparison of Computational Complexity (in %)

No. of Images	CODPS	GAOPS	ACOPS	RLECO
100	70.30	51.87	65.18	80.01
200	68.56	50.29	63.76	78.72
300	66.22	48.09	62.50	77.71
400	65.41	46.46	60.51	76.82
500	63.12	45.32	58.04	76.45

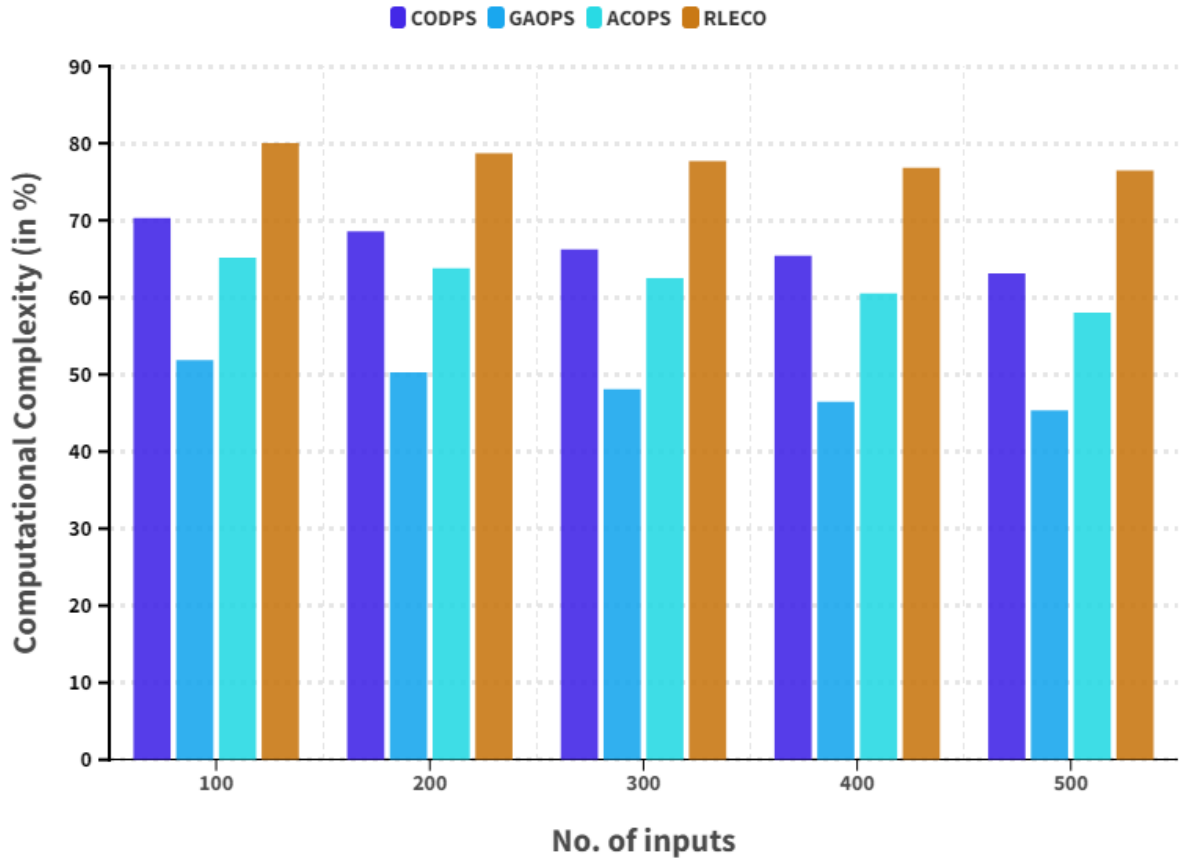

Fig.6: Comparison of Computational Complexity

Fig. 6 shows the comparison of Computational Complexity . In a computation cycle, the existing CODPS obtained 63.12 %, GAOPS obtained 45.32 %, ACOPS reached 58.04 % Computational Complexity. The proposed RLECO obtained 76.45 % Computational Complexity.

3.4 Interference Suppression Efficiency:

This parameter measures the effectiveness of the framework in reducing interference levels in the network. A high interference suppression efficiency means that the framework is successfully removing a significant amount of interference, resulting in improved network performance and user experience. Table.5 shows the comparison of Efficiency between existing and proposed models.

Table.5: Comparison of Efficiency (in %)

No. of Images	CODPS	GAOPS	ACOPS	RLECO
100	77.30	55.87	69.18	82.01
200	75.56	54.29	67.76	80.72
300	73.22	52.09	66.50	79.71
400	72.41	50.46	64.51	78.82
500	70.12	49.32	62.04	78.45

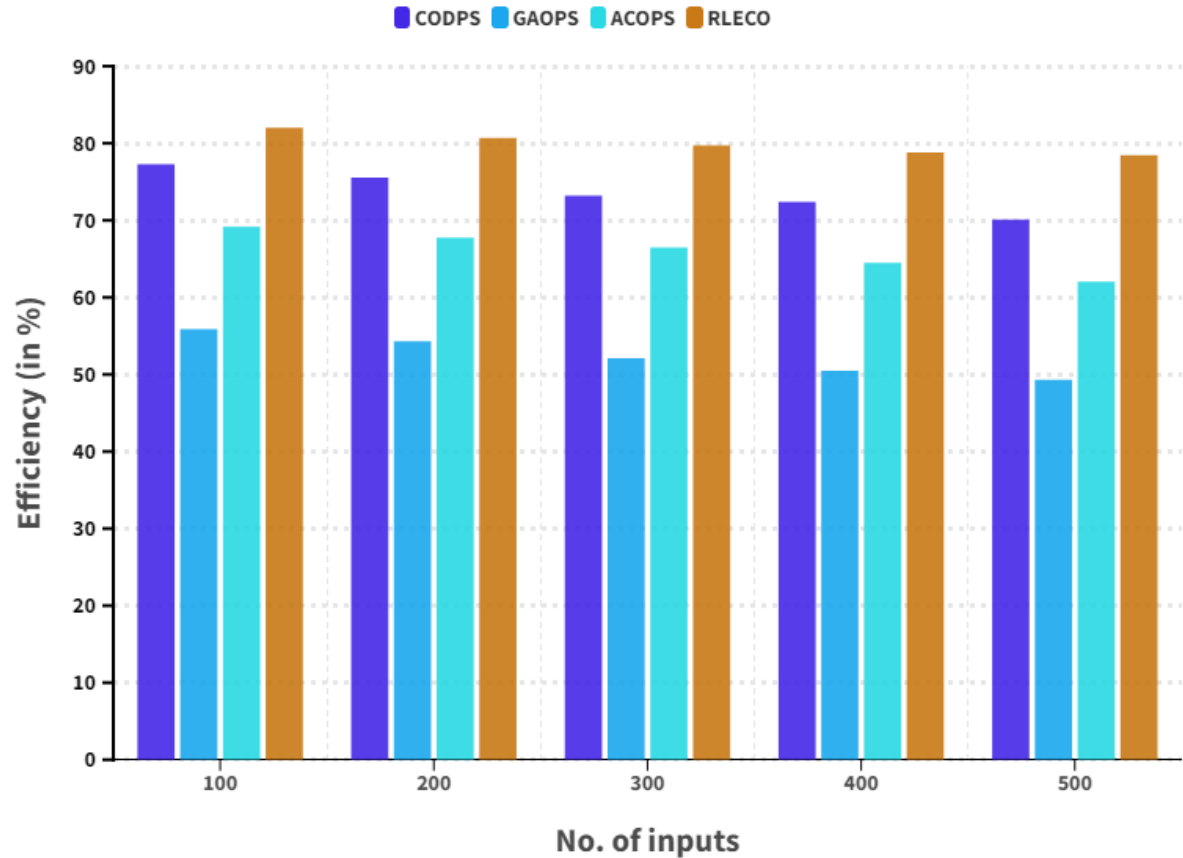

Fig.7: Comparison of Efficiency

Fig. 7 shows the comparison of Efficiency . In a computation cycle, the existing CODPS obtained 70.12%, GAOPS obtained 49.32%, ACOPS reached 62.04 % Efficiency. The proposed RLECO obtained 78.45 % Efficiency.

5. Conclusion

In conclusion, the use of deep peak shaving methods in thermal power generation units can greatly improve energy consumption and efficiency. The implementation of an improved energy consumption framework allows for better management and optimization of power usage, resulting in reduced peak demand and lower operational costs. Through a comprehensive analysis of various deep peak shaving techniques, it is evident that they offer promising solutions for mitigating peak demand and improving the overall performance of thermal power generation units. Further research and implementation of these methods are recommended in order to maximize their potential benefits.

References

- [1] Hong, F., Wang, R., Song, J., Gao, M., Liu, J., & Long, D. (2022). A performance evaluation framework for deep peak shaving of the CFB boiler unit based on the DBN-LSSVM algorithm. *Energy*, 238, 121659.
- [2] Wang, J., Huo, J., Zhang, S., Teng, Y., Li, L., & Han, T. (2021). Flexibility transformation decision-making evaluation of coal-fired thermal power units deep peak shaving in China. *Sustainability*, 13(4), 1882.
- [3] Meng, Y., Cao, Y., Li, J., Liu, C., Li, J., Wang, Q., ... & Yang, Q. (2022). The real cost of deep peak shaving for renewable energy accommodation in coal-fired power plants: Calculation framework and case study in China. *Journal of Cleaner Production*, 367, 132913.

- [4] Ma, T., Li, Z., Lv, K., Chang, D., Hu, W., & Zou, Y. (2024). Design and performance analysis of deep peak shaving scheme for thermal power units based on high-temperature molten salt heat storage system. *Energy*, 288, 129557.
- [5] Ouyang, T., Qin, P., Tan, X., Wang, J., & Fan, J. (2022). A novel peak shaving framework for coal-fired power plant in isolated microgrids: Combined flexible energy storage and waste heat recovery. *Journal of Cleaner Production*, 374, 133936.
- [6] Wang, R., Du, X., Shi, Y., Deng, W., Wang, Y., & Sun, F. (2024). A novel system for reducing power plant electricity consumption and enhancing deep peak-load capability. *Energy*, 131031.
- [7] Zhu, J., Cui, X., & Ni, W. (2022). Model predictive control based control strategy for battery energy storage system integrated power plant meeting deep load peak shaving demand. *Journal of Energy Storage*, 46, 103811.
- [8] Rafayal, S., Alnaggar, A., & Cevik, M. (2024). Optimizing electricity peak shaving through stochastic programming and probabilistic time series forecasting. *Journal of Building Engineering*, 109163.
- [9] Meena, A., Reddy, G. V., & Chavali, D. P. (2024, March). Accelerated CNN Training with Genetic Algorithm. In *2024 IEEE International Conference on Interdisciplinary Approaches in Technology and Management for Social Innovation (IATMSI) (Vol. 2, pp. 1-6)*. IEEE.
- [10] Hu, W. C., Pillai, S. E. V. S., & ElSaid, A. A. (2022). Mobile Health Text Misinformation Identification Using Mobile Data Mining. *International Journal of Mobile Devices, Wearable Technology, and Flexible Electronics (IJMDWTFE)*, 12(1), 1-14.
- [11] Bagheri, F., Dagdougui, H., & Gendreau, M. (2022). Stochastic optimization and scenario generation for peak load shaving in Smart District microgrid: sizing and operation. *Energy and Buildings*, 275, 112426.
- [12] Wei, W., Ye, Z., Wang, Y., Dai, S., Chen, L., & Liu, X. (2022). An economic optimization method for demand-side energy-storage accident backup assisted deep peaking of thermal power units. *Chinese Journal of Electrical Engineering*, 8(2), 62-74.
- [13] Yang, X., Niu, D., Sun, L., Wang, K., & De, G. (2021). Participation of electric vehicles in auxiliary service market to promote renewable energy power consumption: Case study on deep peak load regulation of auxiliary thermal power by electric vehicles. *Energy Science & Engineering*, 9(9), 1465-1476.
- [14] Liang, J., Zhao, X., & Yang, S. (2021). Collaborative optimization model of renewable energy development considering peak shaving costs of various flexibility resources. *Global Energy Interconnection*, 4(4), 394-404.
- [15] Rostamnezhad, Z., Mary, N., Dessaint, L. A., & Monfet, D. (2022). Electricity consumption optimization using thermal and battery energy storage systems in buildings. *IEEE Transactions on Smart Grid*, 14(1), 251-265.
- [16] Fu, C., Gong, L., Hu, J., & Lin, J. (2022, April). Low-carbon constraint-oriented peak shaving optimization method for nuclear power integration into power system. In *2nd International Conference on Mechanical, Electronics, and Electrical and Automation Control (METMS 2022) (Vol. 12244, pp. 1176-1181)*. SPIE.
- [17] Yang, C., Hao, X., Zhang, Q., Chen, H., Yin, Z., & Jin, F. (2023). Performance Analysis of a 300 MW Coal-Fired Power Unit during the Transient Processes for Peak Shaving. *Energies*, 16(9), 3727.
- [18] Zou, Y., Hu, Z., Zhou, S., Luo, Y., Han, X., & Xiong, Y. (2024). Day-Ahead and Intraday Two-Stage Optimal Dispatch Considering Joint Peak Shaving of Carbon Capture Power Plants and Virtual Energy Storage. *Sustainability*, 16(7), 2890.
- [19] Sarmas, E., Spiliotis, E., Marinakis, V., Tzanes, G., Kaldellis, J. K., & Doukas, H. (2022). ML-based energy management of water pumping systems for the application of peak shaving in small-scale islands. *Sustainable Cities and Society*, 82, 103873.
- [20] Wang, H., Han, J., Zhang, R., Sun, M., Sun, Z., Hua, P., ... & Teppo, E. (2023). Heat-power peak shaving and wind power accommodation of combined heat and power plant with thermal energy storage and electric heat pump. *Energy Conversion and Management*, 297, 117732.

- [21] Wu, Z., Li, J., & Li, M. (2023, April). Multi-Alliance Market Subject Auxiliary Peak Shaving Strategy for New Energy Consumption. In 2023 8th Asia Conference on Power and Electrical Engineering (ACPEE) (pp. 892-898). IEEE.
- [22] Dai, F., Jiang, F., Chen, L., Wu, Y., & Xiao, C. (2023). Master–slave game-based optimal scheduling of community-integrated energy system by considering incentives for peak-shaving and ladder-type carbon trading. *Frontiers in Energy Research*, 11, 1247803.
- [23] Campana, P. E., Cioccolanti, L., François, B., Jurasz, J., Zhang, Y., Varini, M., ... & Yan, J. (2021). Li-ion batteries for peak shaving, price arbitrage, and photovoltaic self-consumption in commercial buildings: A Monte Carlo Analysis. *Energy Conversion and Management*, 234, 113889.
- [24] Xu, P., Kang, J., Zhao, W., Xing, Z., & Ji, W. (2022, December). Primary frequency control performance assessment for thermal power plants under deep peak shaving. In 2022 4th International Conference on Electrical Engineering and Control Technologies (CEECT) (pp. 1232-1236). IEEE.
- [25] Zhou, J., Huang, D., & Zhou, L. (2024). Modeling and thermal economy analysis of the coupled system of compressed steam energy storage and Rankine cycle in thermal power plant. *Energy*, 291, 130309.
- [26] Yu, B., Fang, D., Xiao, K., & Pan, Y. (2023). Drivers of renewable energy penetration and its role in power sector's deep decarbonization towards carbon peak. *Renewable and Sustainable Energy Reviews*, 178, 113247.
- [27] Fu, G., Wang, X., Yu, S., Cui, Y., Song, R., Xu, Y., ... & Zhao, H. (2023, May). Consider the Economic Dispatch of Wind-Solar-Photothermal Joint Power System with Green Certificate Trading and Peak Shaving Services. In 2023 6th International Conference on Energy, Electrical and Power Engineering (CEEPE) (pp. 1418-1426). IEEE.
- [28] Liu, D., Zou, M., Liu, M., Li, Y., Jia, H., Peng, X., ... & Yang, Y. (2022) Clearing Price Prediction Model of Power Peak Shaving Auxiliary Service Based on Parallel Deep Learning. Available at SSRN 3957243.
- [29] Ni, B., Cai, X., Meng, Z., Cui, Y., Zhou, Y., & Yang, L. (2023, July). Multi-type Peak Shaving Resource Coordination Optimization Method Considering Carbon Emission Difference. In 2023 5th International Conference on Power and Energy Technology (ICPET) (pp. 1645-1650). IEEE.
- [30] Hu, Y., Chi, Y., Zhao, H., Zhang, M., Zhou, W., & Yuan, Y. (2022). The value allocation model of renewable portfolio standards considering the contribution of renewable energy consumption on the demand side. *Journal of Cleaner Production*, 380, 135152.