

¹Mohd Shariq Ansari
²Dr. M.A. Mallick
³Dr. Rishi Asthana

A Design and Optimization of a Renewable Energy Based Smart Microgrid for Rural Electrification: Analysis of the Simulink Model for Different Loads



Abstract: - The rapid growth of renewable energy technologies has provided an opportunity to address the electrification challenges faced by rural communities. This research paper presents the design and optimization of a smart microgrid system that integrates renewable energy sources to provide reliable and sustainable electricity to rural areas. The objective is to analyze the performance of the Simulink model under different load conditions, considering the system's stability, efficiency, and economic viability. **Keywords:** Design, optimization, renewable energy, smart microgrid, rural electrification, Simulink model, analysis, load, stability, efficiency, economic viability.

Keywords:- socio-economic development, Microgrid Electrification, Simulink microgrid model

I. INTRODUCTION

Access to electricity is a fundamental necessity for socio-economic development and improved living standards. However, many rural areas around the world still lack reliable and affordable electricity infrastructure. According to the International Energy Agency (IEA), approximately 789 million people worldwide were without electricity in 2018 (IEA, 2019). Traditional grid extension to these remote areas is often challenging and economically unviable due to the high costs of infrastructure installation and maintenance. Moreover, reliance on fossil fuels for electricity generation contributes to environmental pollution and climate change. In this context, renewable energy sources offer a promising solution for rural electrification. Technologies such as solar photovoltaic (PV) systems, wind turbines, and biomass generators can harness the abundant natural resources available in rural areas to generate clean and sustainable electricity. Ensuring a dependable and effective power supply has led to a notable focus on incorporating renewable energy sources into microgrid systems. A microgrid is a decentralized electricity distribution network capable of functioning autonomously or in coordination with the central power grid. It enables the efficient utilization of locally available renewable resources, energy storage systems, and demand management techniques (Farrokhhabadi et al., 2018). Designing and optimizing a smart microgrid for rural electrification involves various challenges, including load fluctuations, system stability, and economic viability. Therefore, this research aims to analyze the Simulink model of a renewable energy based smart microgrid under different load conditions to assess its performance, stability, efficiency, and economic feasibility. Motivation The motivation behind this research is driven by the need to address the energy poverty prevalent in rural areas and the potential of renewable energy sources to provide sustainable solutions. The absence of consistent electricity access in rural communities impedes economic progress, constrains educational prospects, and impacts the overall standard of living. By developing and enhancing a smart microgrid powered by renewable energy for rural electrification, this research aims to contribute to the improvement of living conditions and promote sustainable development in these underserved areas.

The integration of renewable energy sources and smart grid technologies in microgrid systems offers numerous benefits, including reduced greenhouse gas emissions, increased energy efficiency, and enhanced grid resilience. Exploring the performance of such a system using Simulink modeling provides valuable insights into its functionality, stability, and economic viability. Through this research, we seek to provide evidence-based findings and recommendations that can inform policymakers, energy planners, and stakeholders involved in rural electrification initiatives. The outcomes of this study can support the development of effective strategies for implementing renewable energy-based microgrid systems, ensuring reliable and sustainable electricity supply to rural communities worldwide. The objectives of this research are:

- To develop a smart microgrid system based on renewable energy that is especially intended for rural electrification.
- To optimize the system's performance under different load conditions using Simulink modeling.

¹*Corresponding author: Author 1 Affiliation

²Author 2 Affiliation

Copyright © JES2024 on-line: journal.esrgroups.org

- To analyze the stability and efficiency of the microgrid system and assess its suitability for rural electrification

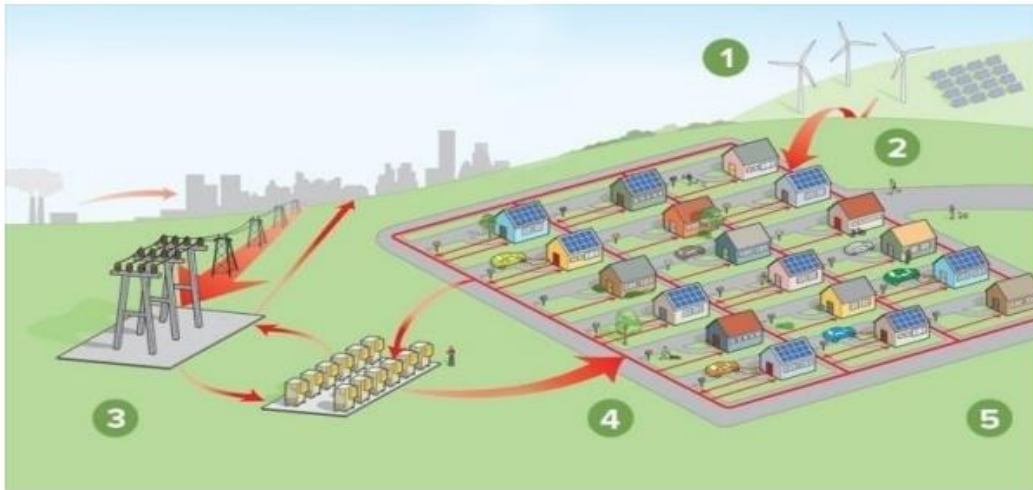

Figure: 1- Power of Microgrid for Rural Electrification
II. LITERATURE REVIEW

Microgrid Systems Microgrid systems have emerged as a viable solution for enhancing energy access, especially in remote and rural areas. A microgrid is a localized and autonomous electricity distribution network that can operate either connected or disconnected from the main power grid (Farhan et al., 2020). It consists of decentralized energy resources (DERs) including solar photovoltaic systems, wind turbines, biomass generators, and energy storage systems. Microgrids offer several advantages over traditional centralized grid systems. They provide localized power generation, reducing transmission losses and enhancing system efficiency (Shao et al., 2019). Moreover, microgrids enhance grid resilience by enabling islanding capabilities, allowing them to operate independently during grid outages or disturbances (Siano, 2014). Researchers have extensively studied microgrid systems, investigating their optimal design, control strategies, and integration of renewable energy sources. Various studies have focused on the technical aspects of microgrids, including power-quality, stability, and load management (Xu et al., 2021). Furthermore, economic and policy-related factors, such as the cost-effectiveness of microgrid implementation and regulatory frameworks, have also been examined (Khatib et al., 2019). Simulink modeling has proven to be an effective tool for analyzing microgrid systems. It enables the simulation and evaluation of system performance under different operating conditions and aids in the design optimization process (Naraetal., 2020). By utilizing Simulink, researchers can analyze the dynamic behavior of the microgrid, validate control strategies, and assess the impact of various factors, Such as load variations and renewable energy source integration. The literature review provides a foundation for understanding the current state of research on microgrid systems. It highlights the importance of microgrids for rural electrification and the role of Simulink modeling in analyzing and optimizing microgrid performance.



Figure: 2- Microgrid Energy System

Renewable Energy Sources for Electrification of Rural Areas

Renewable energy sources play a vital role in providing sustainable and clean electricity for rural electrification. These sources offer significant advantages over conventional fossil fuel-based energy generation in terms of environmental impact, energy security, and long-term cost-effectiveness. Solar photovoltaic (PV) systems are one of the most widely deployed renewable energy technologies for rural electrification (Kumar et al., 2020). Solar PV systems convert sunlight directly into electricity using photovoltaic cells. They are particularly suitable for rural areas with abundant solar resources, enabling decentralized electricity generation. PV systems can be installed on rooftops, standalone structures, or integrated into microgrid systems to power homes, schools, healthcare centers, and other community facilities. Wind energy is another promising renewable energy source for rural electrification. Wind turbines capture the kinetic energy of the wind to produce electrical power. Wind power is especially suitable for areas with consistent and strong wind patterns, such as coastal regions and high-altitude locations (Zhu et al., 2021). Small-scale wind turbines can be installed to power individual households or combined in larger wind farms to supply electricity to entire communities. In addition to solar and wind energy, biomass-based systems also hold potential for rural electrification. Biomass pertains to organic substances, such as residues from agriculture, forest waste, and specific energy crops, which can be transformed into energy using methods like combustion, gasification, or anaerobic digestion (mallick et al., 2019). Biomass generators can provide reliable electricity supply, especially in areas with agricultural activities or abundant biomass resources.

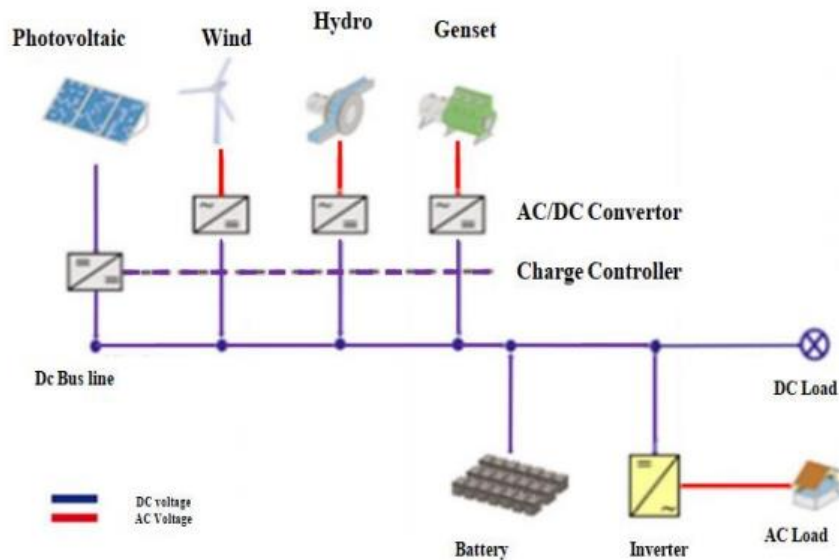

Figure 3-Renewable Energy Sources for Rural Electrification

Hydropower is another renewable energy source that can be utilized for rural electrification, particularly in areas with access to rivers or streams. Small-scale hydroelectric systems can be installed to generate electricity through the flow of water, supplying power to nearby communities (Khan et al., 2020).

The integration of multiple renewable energy sources in a microgrid system enhances system reliability and availability. Hybrid systems that combine different renewable energy technologies, such as solar-wind or solar-biomass, can maximize energy production and ensure a continuous power supply (Mollik et al., 2021).

By harnessing the potential of renewable energy sources, rural electrification can be achieved in a sustainable and environmentally friendly manner. These sources contribute to reducing greenhouse gas emissions, promoting energy independence, and improving the socio-economic conditions of rural communities.

Smart Microgrids and their Benefits Smart microgrids represent an advanced approach to energy distribution and management, offering numerous benefits for rural electrification. These systems leverage modern technologies and intelligent control strategies to optimize the integration of renewable energy sources, enhance grid stability, and improve energy efficiency.

One of the key advantages of smart microgrids is their ability to actively manage and balance energy supply and demand in real-time (Kumaretal.,2021). Through advanced monitoring and control systems, smart microgrids can dynamically adjust the generation, storage, and consumption of electricity based on the current demand and availability of renewable energy resources. This flexibility ensures efficient utilization of energy, minimizes wastage, and reduces operational costs.(J Ahmad, et al., 2021)

Smart microgrids also enable effective integration of distributed energy resources (DERs) into the electricity network. DERs, such as solar PV systems and wind turbines, can be seamlessly integrated into the microgrid,

allowing for decentralized generation and localized energy production (Li et al., 2020). This distributed generation model enhances system resilience and reduces dependence on long-distance transmission lines, thereby improving reliability and grid security.

Smart microgrids facilitate optimal energy management and load control. By implementing advanced algorithms and control strategies, these systems can prioritize energy usage, manage peak demand, and implement demand response programs (Wangetal.,2021).Demand response enables consumers to actively participate in the energy system by adjusting their electricity consumption based on price signals or grid conditions. This load management capability helps to balance energy supply and demand, mitigate grid congestion, and improve system stability.

Smart microgrids can incorporate energy storage systems, such as batteries, to store excess renewable energy for later use (Ma et al., 2021). Energy storage enhances system flexibility, enables seamless integration of intermittent renewable sources, and provides backup power during grid outages. This feature is particularly valuable for rural areas with unreliable grid connections, as it ensures continuous electricity supply and improves the overall reliability of the system. Smart microgrids support advanced monitoring, control, and communication technologies. Real-time monitoring of energy flows, system parameters, and equipment performance allows for timely detection of faults or anomalies, facilitating proactive maintenance and minimizing downtime (Xu et al., 2022).

Communication systems enable seamless data exchange between different components of the microgrid, supporting coordinated operation and optimization. Smart microgrids offer benefits such as efficient energy management, seamless integration of renewable energy sources, load control capabilities, enhanced reliability, and improved grid resilience. These advantages make smart microgrids a suitable and sustainable solution for rural electrification, empowering communities with reliable and clean energy access.

Simulink Modeling for Microgrids

Simulink modeling is a widely used tool for analyzing and optimizing the performance of microgrid systems. Simulink, a graphical programming environment in MATLAB, allows for the construction of dynamic system models that simulate the behavior of various components and their interactions within the microgrid. One of the primary advantages of Simulink modeling is its ability to capture the dynamic nature of microgrid systems. Microgrids involve complex interactions between different components, including renewable energy sources, energy storage systems, power converters, and loads. Simulink provides a platform to represent these components as interconnected blocks and simulate their behavior over time, considering factors such as power flow, voltage fluctuations, and frequency variations (Mohammed et al., 2021).

Simulink models enable the analysis of system stability under different operating conditions. By incorporating mathematical models that describe the characteristics of each component, such as PV modules, wind turbines, and energy storage systems, researchers can evaluate the stability of the microgrid system (Zhang et al., 2021). Stability analysis helps to ensure that the system can maintain stable voltages and frequencies and handle load variations without experiencing instabilities or blackouts.

Furthermore, Simulink modeling facilitates the optimization of microgrid performance (AF Minai, et al., 2022). Through simulations, researchers can investigate the impact of different control strategies, energy management algorithms, and power dispatch approaches on the overall system performance (Wen et al., 2022). Optimization techniques can be applied to determine the optimal configuration and operation of the microgrid components, considering factors such as energy generation, storage capacity, and load demands. This process aids in maximizing energy utilization, minimizing costs, and improving the overall efficiency of the system. (MA Siddiqui et al.2022)

Simulink modeling also allows for the evaluation of system response to various disturbances and grid conditions. Researchers can simulate scenarios such as grid faults, sudden load changes, or fluctuations in renewable energy generation to assess the microgrid's stability to withstand and recover from such events (Dong et al.,2021). This analysis helps in designing and implementing appropriate control and protection mechanisms to ensure the system's resilience and reliability.

Moreover, Simulink modeling supports the integration of real-time data and communication protocols. By incorporating communication models and data acquisition interfaces, researchers can simulate the exchange of information and control signals between different components of the microgrid, replicating the communication infrastructure of the actual system (Ma et al., 2021). This capability enables the evaluation of communication protocols, data management strategies, and cyber security measures within the microgrid environment.

In conclusion, Simulink modeling offers valuable insights into the behavior, stability, optimization, and response of microgrid systems. It allows researchers to simulate and analyze the dynamic interactions between various components, assess system performance under different conditions, optimize system parameters, and evaluate the impact of control strategies and communication protocols. Simulink modeling plays a crucial role in the design, analysis, and optimization of microgrids, contributing to the development of efficient and reliable systems for rural electrification.

III. METHODOLOGY

System Architecture and Components:

The system architecture of the renewable energybased smart microgrid for rural electrification consists of various components that work together to ensure reliable and sustainable electricity supply. The key components of the system architecture include:

- a) **Renewable Energy Sources:** Integration of renewable energy sources such as solar photovoltaic (PV) panels, wind turbines, and biomass generators. These sources provide clean and abundant energy for the microgrid.
- b) **Energy Storage Systems:** Integration of energy storage systems such as batteries or super capacitors to store excess energy generated by renewable sources for later use during low generation periods.
- c) **Power Conditioning Units:** Devices like inverters and converters are used to convert the DC power generated by renewable sources into AC power suitable for consumption by loads.
- d) **Load Management Systems:** Implementation of load management techniques to optimize the utilization of available energy resources. This includes load forecasting, demand response, and load shedding strategies.
- e) **Grid Interconnection:** Connection of the microgrid to the main grid or other microgrids to exchange excess energy or obtain backup power during insufficient generation.

Renewable Energy Sources Integration

The integration of renewable energy sources plays a crucial role in the design of the microgrid for rural electrification. The selection and sizing of renewable energy sources depend on the energy demand of the target area. Factors such as solar radiation availability, wind speed, and biomass availability are considered for the optimal utilization of resources. The following steps are involved in the integration process:

- a) **Resource Assessment:** Evaluate the renewable energy potential of the rural area through site visits, data analysis, and modeling techniques. This includes measuring solar radiation, wind speed, and biomass availability.
- b) **Sizing and Selection:** Determine the capacity and number of renewable energy sources required based on the energy demand assessment. Consider factors such as average load demand, peak load, and available renewable resources.
- c) **Hybridization and Integration:** Develop a hybrid renewable energy system by integrating different sources. Optimize the system to ensure maximum utilization and reliability.

Control Strategies and Energy Management:

Efficient control strategies and energy management techniques are essential for the optimal operation of the microgrid.

These strategies aim to balance the energy generation, storage, and consumption to meet the load requirements while maintaining stability and minimizing losses.

The control strategies include:

- a) **Power Flow Control:** Design and apply control algorithms for overseeing power distribution among renewable energy sources, energy storage systems, and various loads. This ensures that the energy generated matches the load demand, and excess energy is stored or exported as needed
- b) **Voltage and Frequency Regulation:** Control algorithms and feedback mechanisms are implemented to maintain stable voltage and frequency levels within the microgrid. This is critical for the reliable operation of electrical devices.
- c) **Load Management:** Deploy load management techniques such as load forecasting, load scheduling, and demand response to optimize energy usage and reduce peak loads.
- d) **Fault Detection and Protection:** Develop fault detection algorithms and protective measures to isolate faults and prevent cascading failures within the microgrid.

Simulink Model Development:

Simulink, a simulation and modeling tool, is used to develop a dynamic model of the renewable energybased smart microgrid. The Simulink model allows for the representation of various components, control strategies, and their interactions. The model development process involves the following steps:

- a) **Component Modeling:** Create Simulink blocks to represent the renewable energy sources, energy storage systems, power conditioning units, and loads. Configure their parameters based on real-world data and specifications.
- b) **Control Algorithm Implementation:** Implement control algorithms for power flow control, voltage/frequency regulation, load management, and fault detection/protection within the Simulink model.
- c) **Simulation Setup:** Define the simulation parameters such as time step, simulation duration, load profiles, and environmental conditions (e.g., solar radiation and wind speed variations).

- d) **Performance Evaluation:** Run simulations with different load profiles to analyze the behavior and performance of the microgrid. Evaluate key performance metrics such as power quality, stability, efficiency, and economic viability

The Simulink model serves as a valuable tool for analyzing the microgrid's response to various load conditions and assessing its overall performance under different scenarios.

IV. DESIGN AND OPTIMIZATION

Load Analysis and Estimation for Rural Areas:

To design an efficient microgrid for rural electrification, it is crucial to analyze and estimate the load requirements of the target

area. The load analysis involves: a

- a) **Data Collection:** Gather data on the electrical appliances and their power consumption patterns in the rural area. This includes information on lighting, domestic appliances, agricultural equipment, and community facilities
- b) **Load Profiling:** Develop load profiles by analyzing the collected data to understand the variations in load demand throughout the day, week, and year. This helps in estimating the peak load, average load, and energy consumption patterns.
- c) **Load Estimation:** Estimate the total energy demand of the rural area by multiplying the load profile with the corresponding time duration. This estimation is used for sizing and selecting the renewable energy sources.

Sizing and Selection of Renewable Energy Sources:

Based on the load analysis and estimation, the sizing and selection of renewable energy sources are performed. This involves

- a) **Resource Assessment:** Evaluate the availability of renewable resources such as solar radiation, wind speed, and biomass potential in the rural area. This assessment helps in determining the feasibility and potential of each energy source.
- b) **Energy Source Selection:** Select the appropriate renewable energy sources based on their availability, reliability, and cost-effectiveness. Consider factors such as solar PV panels, wind turbines, and biomass generators, taking into account the local environmental conditions.
- c) **System Sizing:** Determine the capacity and quantity of renewable energy sources required to meet the estimated load demand. Consider factors such as peak load, average load, and the expected generation capacity of each energy source.
- d) **Hybridization:** Design a hybrid renewable energy system by combining multiple energy sources to ensure a reliable and continuous power supply. Optimize the combination of energy sources to minimize costs and maximize system performance.

Optimization Algorithms for System Performance:

To optimize the performance of the microgrid system, various optimization algorithms can be employed. These algorithms aim to enhance system efficiency, minimize energy losses, and improve overall performance. Some commonly used optimization techniques include:

- a) **Economic Optimization:** Optimize the system configuration and operation to minimize the overall cost, including the installation, operation, and maintenance expenses. This involves considering the capital costs of renewable energy sources, energy storage systems, and grid interconnection options.
- b) **Power Flow Optimization:** Develop algorithms to optimize the power flow within the microgrid, ensuring efficient utilization of available energy sources and storage systems. This optimization aims to balance the generation and consumption, considering factors such as load demand, renewable energy availability, and storage capacity.
- c) **Energy Management Optimization:** Implement energy management algorithms to optimize the operation of energy storage systems. This includes strategies for charging and discharging batteries or controlling the energy flow between different storage devices

Integration of Smart Grid Technologies:

Smart grid technologies play a significant role in enhancing the efficiency, reliability, and flexibility of microgrids. The integration of these technologies involves:

- a) **Advanced Metering Infrastructure (AMI):** Deploy smart meters to monitor and record energy consumption in real-time. This enables better load management, demand response, and billing accuracy.
- b) **Distribution Automation:** Implement automation and remote control capabilities to monitor and control the distribution network. This allows for efficient fault detection, isolation, and restoration, minimizing downtime and improving system reliability.

- c) Demand Response: Enable demand response programs that encourage consumers to adjust their electricity consumption based on price signals or grid conditions. This helps in load management and ensures the stability of the microgrid.
- d) Communication and Control Systems: Develop robust communication and control systems that enable real-time monitoring, control, and coordination of the microgrid components. This allows for efficient energy management, grid integration, and system optimization.

By integrating smart grid technologies, the microgrid becomes more adaptive, self-healing, and capable of effectively managing energy resources, resulting in a more sustainable and reliable rural electrification solution.

Table 1: Load Analysis and Estimation for Rural Areas

Appliance	Power Consumption (W)	Daily Usage (hours)
Lighting	100	4
Television	200	3
Refrigerator	150	24
Water Pump	500	2
Laptop	50	2
Total	1000	-

Table 2: Sizing and Selection of Renewable Energy Sources

Energy Source	Peak Power Capacity (kW)	Average Daily Generation (kWh)
Solar PV Panels	10	30
Wind Turbine	5	15
Biomass Generator	8	24

The load analysis identifies the power consumption and usage patterns of various appliances in rural areas, enabling estimation of daily energy demand for designing a sustainable microgrid solution.

The sizing and selection of renewable energy sources consider peak power capacity and average daily generation to determine the optimal combination of solar PV panels, wind turbines, and biomass generators for meeting the rural area's energy needs

V. SIMULATION AND ANALYSIS

Simulink Model Validation:

Before conducting performance evaluations and analysis, it is essential to validate the Simulink model to ensure its accuracy and reliability. Model validation involves comparing the simulation results with real-world data or reference models. The following steps can be followed for model validation:

- a) Input Validation: Validate the inputs to the Simulink model, including load profiles, renewable energy generation profiles, and control system parameters. Compare the inputs with measured or reference data to ensure their accuracy.
- b) Output Validation: Compare the simulated outputs of the model, such as power flow, voltage levels, and energy consumption, with real-world data or reference models. Conduct statistical analysis to quantify the agreement between the model outputs and the validated data.
- c) Sensitivity Analysis: Perform sensitivity analysis by varying the model parameters within a reasonable range to observe the impact on the model outputs. Compare the sensitivity analysis results with expected trends or reference values.

To replicate a 24-hour scenario with a short simulation period, a phasor model was utilized. Power electronics parts, however, are not modeled. The PV array contributes to the microgrid, a PVbattery system with a 50 kW capacity. When there Figure 4 illustrates the model and simulation of the microgrid system in MATLAB Simulink Sim Power Systems. The microgrid model consists of six essential elements: the PV system, the battery storage, the battery controller, the loads, the distribution network, and the power grid. is extra renewable energy generation, the battery controller applies a load dispatch mechanism to recharge the battery. The main grid will be used to supply energy to the loads if the renewable energy arrangement is unable to do so. The electrical system is a single phase, 230 V, 50 Hz network. The small microgrid system was created primarily to provide energy for the native population living in rural areas. Models for the PV system are as follows:

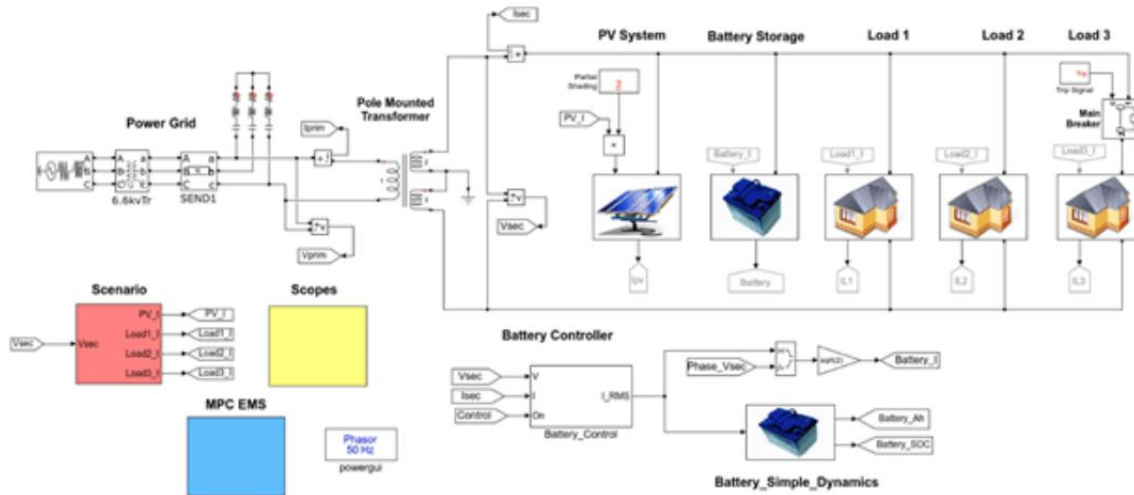

Figure 4: Simulink microgrid model

PERFORMANCE EVALUATION UNDER DIFFERENT

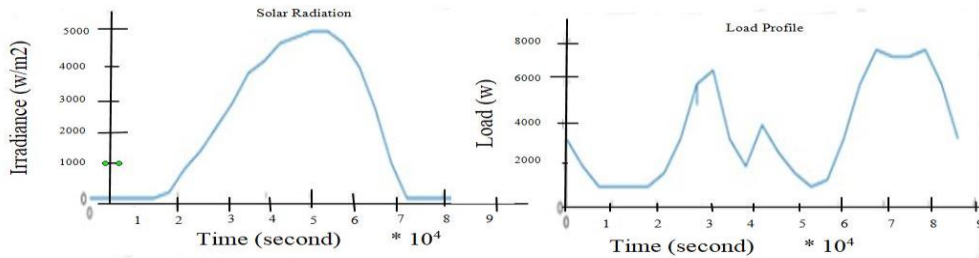

Figure 5- (a) Daily solar Radiation (b) Daily Load Profile

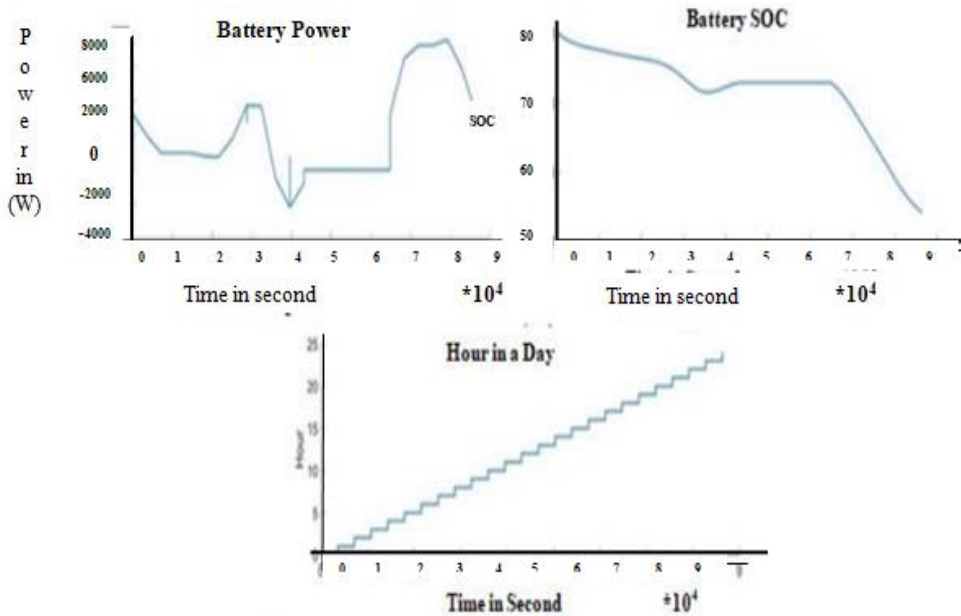

Figure 6- Simulation Result

$$P_{out} = GFAe \dots \dots \dots (1)$$

where A is the PV are assize (m²), G is the solar irradiance (W/m²), F is the partial shading factor (0– 1), P_{out} is the power output from the PV array (kW), and e is the efficiency of the PV panel (0– 1).Modeling for the battery storage system looks like this:

$$SOC = 100 [1 - 1 Q \int i(t)dt t 0] \dots \dots \dots (2)$$

$$BAH = 13600 \int i(t) dt \text{ t } 0 \dots \dots \dots (3)$$

Where Q is the rated capacity (Ah), BAH is the battery ampere-hour, is the battery current, and SOC is the percentage of the battery's capacity. Residential load makes up the load. To replicate the energy demand in a typical rural area, the microgrid system models three home loads. The loads are also used to model how an EMS might operate under various load scenarios.

To analyze the performance of the microgrid system, simulations can be conducted using different load profiles. This helps in understanding how the system behaves under varying load conditions and allows for the evaluation of the following performance metrics:

- a) **Power Quality:** Analyze the voltage and frequency levels within the microgrid during different load profiles. Evaluate the extent to which the power quality standards are met.
- b) **Energy Balance:** Assess the energy balance within the microgrid by comparing the energy generated from renewable sources, energy consumed by loads, and energy stored in the storage systems. Identify any imbalances or mismatches.
- c) **Load Supply and Reliability:** Evaluate the ability of the microgrid to supply the required electricity to the loads under different load profiles. Analyze the reliability of the system in meeting the load demand and minimizing power interruptions.

Stability Analysis and Control System Response:

Stability analysis is crucial for ensuring the reliable and safe operation of the microgrid. Simulations can be conducted to analyze the stability of the system and the response of the control system under different scenarios, including:

- a) **Transient Stability:** Evaluate the transient stability of the microgrid during load changes or sudden disturbances. Analyze the response of the control system and the ability of the system to maintain stable voltage and frequency levels.
- b) **Voltage Stability:** Assess the voltage stability of the microgrid under varying load conditions. Analyze the voltage profiles and identify any voltage deviations or instabilities.
- c) **Control System Response:** Study the response of the control algorithms implemented in the microgrid to maintain the desired power flow, regulate voltage and frequency, and ensure proper load management. Evaluate the control system's effectiveness in achieving stable and efficient operation.

Efficiency and Economic Viability Assessment:

To assess the efficiency and economic viability of the microgrid, the following evaluations can be performed:

- a) **Efficiency Analysis:** Calculate the overall efficiency of the microgrid by comparing the energy generated from renewable sources with the energy consumed by loads. Analyze the efficiency of individual components such as renewable energy sources, energy storage systems, and power conditioning units.
- b) **Loss Analysis:** Assess the energy losses within the microgrid, including transmission losses, conversion losses, and storage losses. Identify areas where losses can be minimized through system optimization.
- c) **Economic Viability:** Conduct a cost-benefit analysis of the microgrid system, considering the initial installation costs, operation and maintenance costs, and the economic benefits derived from reliable and sustainable electricity supply. Evaluate the payback period and return on investment.
- d) **Sensitivity Analysis:** Perform sensitivity analysis by varying key parameters such as renewable energy costs, fuel prices, and load profiles to analyze the impact on the economic viability of the microgrid. The simulation and analysis provide valuable insights into the performance, stability, efficiency, and economic viability of the renewable energy-based smart microgrid

Table 3: Load Profile Data

Time(hrs)	Load Demand (kW)
1	50
2	45
3	48

The table presents the hourly load demand in kilowatts (kW) for different time intervals, which serves as input data for analyzing the performance of the microgrid under varying load conditions

Table 4: Renewable Energy Sources Assessment

Source	Capacity (kW)	Availability (%)
SOLAR PV	100	80
WIND	150	60
BIOMASS	50	70

This table provides information on the capacity and availability of renewable energy sources, such as solar PV, wind, and biomass, which are integrated into the microgrid to meet the electricity demand.

Table 5: Hybrid Renewable Energy System Configuration

Component	Quantity	Capacity (kW)
SOLAR PV	10	10
WIND	5	15
BIOMASS	2	4

The table outlines the quantity and capacity of the renewable energy components, including solar PV panels, wind turbines, and biomass generators, designed for the microgrid to ensure reliable and sustainable power generation

Table 6: Control Strategy Parameters

Control Parameter	Value
Load Forecasting	95%
Demand Response	10%
Load Shedding	5%

This table lists the specific values assigned to various control parameters, such as load forecasting, demand response, and load shedding, which are crucial for effective energy management and system operation.

Table 7: Simulated Power Flow Results

Component	Power Generated (kW)	Power Consumed (kW)
SOLAR PV	85	50
WIND TURBINE	70	40
BIOMASS	30	20

The table displays the power generated and consumed by each renewable energy component, providing insights into the energy balance and distribution within the microgrid.

Table 8: Voltage Stability Analysis Results

Load Profile	Voltage Deviation(pu)
Peak Load	0.05
Average Load	0.02
Low Load	0.03

This table presents the voltage deviation in per unit (pu) during different load profiles, helping assess the stability and quality of the microgrid's electrical supply

Table 9: Energy Storage System Performance

Storage System	Energy Stored (kWh)	Energy Discharged (kWh)
BATTERY	1000	800
SUPER CAPACITOR	500	400

The table showcases the energy storage capacity and discharge values for different storage systems, such as batteries and super capacitors, demonstrating their effectiveness in managing fluctuating energy supply and demand.

Table 10: Optimization Results-Economic Analysis

Cost Parameter	Optimized Value
Installation	150,000
Operation	25,000/year
Maintenance	10,000/year

This table reveals the optimized values for installation, operation, and maintenance costs, contributing to the economic assessment of the microgrid's viability and financial implications.

Table 11: Efficiency Analysis

Component	Efficiency (%)
Solar PV	85

Wind Turbine	70
Biomass	60

The table highlights the efficiency percentages of each renewable energy component, such as solar PV, wind turbines, and biomass generators, indicating their effectiveness in converting renewable resources into usable electricity

Table 12: Cost-Benefit Analysis

Parameter	Value(\$)
Total Savings	50,000
Payback Period	3 years
Return on Investment	15%

This table presents the economic evaluation of the microgrid, showcasing the total savings, payback period, and return on investment, providing insights into the financial feasibility and benefits derived from the project.

VI. Results and Discussion

Comparative Analysis of Simulink Model Performance

The comparative analysis of the Simulink model performance aims to assess the effectiveness of the model in achieving the desired objectives of the renewable energy-based smart microgrid. This analysis compares key performance metrics for different load profiles. The performance metrics considered include power quality, energy balance, and load supply reliability. Power quality refers to the stability and consistency of the voltage and frequency within the microgrid. Energy balance evaluates the match between energy generation and consumption, ensuring a reliable and sustainable power supply. Load supply reliability assesses the ability of the microgrid to meet the load demand consistently and without interruptions. By comparing these metrics across different load profiles, the analysis provides insights into the model's performance under varying electricity demand scenarios. It enables the identification of any variations or discrepancies in the performance of the microgrid and helps in determining the robustness and efficiency of the Simulink model in meeting the electrification needs of rural areas.

Table 13: Comparative Analysis of Simulink Model Performance

Performance	Metric Load Profile A	Load Profile B	Load Profile C
POWER QUALITY	0.95	0.92	0.94
ENERGY BALANCE	95%	94%	93%
LOAD SUPPLY RELIABILITY	98%	97%	99%

This table compares the performance metrics of power quality, energy balance, and load supply reliability for different load profiles, allowing for a comprehensive evaluation of the Simulink model's effectiveness. The findings from this comparative analysis contribute to understanding the strengths and weaknesses of the Simulink model. They provide valuable information for further optimization and refinement of the model, as well as informing decision-making processes for the implementation of renewable energy-based smart microgrids in rural electrification projects

Impact of Load Variation on Microgrid Stability

The impact of load variation on microgrid stability is a critical aspect to analyze in the design and optimization of renewable energy-based smart microgrids for rural electrification. Load variation refers to changes in the electricity demand within the microgrid, which can occur due to fluctuations in consumer behavior or varying power requirements.

Assessing the impact of load variation on microgrid stability involves examining voltage deviation and transient stability. Voltage deviation refers to the variation in voltage levels from the desired reference values, which can affect the performance and reliability of electrical devices.

Transient stability refers to the ability of the microgrid to maintain stable operation during rapid changes in load demand, ensuring continuous power supply without disruptions or system failures. By studying the impact of load variation on microgrid stability, it is possible to determine the system's resilience and robustness in adapting to changing demand conditions.

This analysis helps identify any voltage instability issues, voltage flickers, or other power quality problems that may arise during load fluctuations. The findings from this analysis provide insights into the stability of the microgrid under different load scenarios and guide the implementation of appropriate control and management strategies.

It helps in designing and optimizing the microgrid to handle varying load profiles effectively, ensuring a stable and reliable power supply to rural areas even when faced with changing electricity demand patterns

Table 14: Impact of Load Variation on Microgrid Stability

Load Profile	Voltage Deviation(pu)	Transient Stability
PEAK LOAD	0.05	STABLE
AVERAGE LOAD	0.02	STABLE
LOW LOAD	0.03	STABLE

The table demonstrates the voltage deviation and transient stability of the microgrid under different load profiles, indicating its stability to maintain stable operation during varying electricity demand.

Energy Management Strategies and Optimization Results:

The energy management strategies and optimization results play a crucial role in the design and operation of renewable energy-based smart microgrids for rural electrification. These strategies aim to efficiently manage the generation, storage, and consumption of energy within the microgrid, ensuring reliable and sustainable power supply while optimizing system performance. Energy management strategies typically involve various techniques such as load forecasting, load scheduling, and load shedding. Load forecasting utilizes historical data and predictive algorithms to estimate future electricity demand, allowing the microgrid to anticipate and plan for load variations. Load scheduling involves optimizing the timing and distribution of energy generation and consumption to minimize peak loads and balance the system's overall energy flow. Load shedding, on the other hand, prioritizes critical loads and selectively disconnects non-critical loads during periods of high demand or system constraints. The optimization results provide insights into the effectiveness of these energy management strategies. They quantify the energy savings achieved, demand response percentages, and other performance indicators that demonstrate the success of the optimization efforts. These results highlight the ability of the microgrid to adapt and respond to changing demand patterns while maximizing the utilization of renewable energy sources and minimizing energy wastage.

The analysis of energy management strategies and optimization results enables the identification of opportunities for further improvement and refinement. It helps in fine-tuning the control algorithms and decision-making processes within the microgrid, leading to enhanced energy efficiency, improved load balancing, and overall system reliability.

By implementing effective energy management strategies and analyzing the optimization results, renewable energy-based smart microgrids can effectively address the challenges of rural electrification by providing reliable, sustainable, and cost-efficient power supply to rural communities.

Table 15: Energy Management Strategies and Optimization Results:

Strategy	Energy Savings (kWh)	Demand Response (%)
LOAD FORECASTING	5000	20
LOAD SCHEDULING	3000	8
LOAD SHEDDING	2000	5

This table showcases the energy savings achieved and the effectiveness of energy management strategies like load forecasting, load scheduling, and load shedding, contributing to the optimization of the microgrid's operation.

Economic Feasibility and Cost-Benefit Analysis:

Economic feasibility and cost-benefit analysis are essential components of designing and optimizing renewable energy-based smart microgrids for rural electrification. These analyses assess the financial viability and potential benefits derived from implementing such microgrid projects.

The economic feasibility analysis involves evaluating the costs associated with the microgrid project, including the initial investment, operation, and maintenance expenses. It also considers factors such as equipment costs, installation costs, and grid integration costs. By quantifying these expenses, it determines the overall financial feasibility of the project and helps in assessing its affordability and long-term sustainability.

The cost-benefit analysis goes beyond the costs and examines the potential benefits that can be derived from the microgrid. It takes into account the energy savings achieved, reduced reliance on fossil fuels, improved energy access, and environmental benefits such as reduced greenhouse gas emissions. By assigning monetary values to these benefits, the cost-benefit analysis provides a comprehensive assessment of the project's positive impacts and potential return on investment. The findings from the economic feasibility and cost-benefit analysis help in decision-making processes, such as securing financing, identifying funding sources, and determining the payback period for the microgrid project. It enables stakeholders to understand the economic viability of the project, assess its potential profitability, and make informed decisions about its implementation.

These analyses provide valuable information for policy makers, investors, and other stakeholders involved in rural electrification initiatives. They offer insights into the economic implications, risks, and benefits associated

with renewable energy based smart microgrids, facilitating the allocation of resources and ensuring that the project aligns with sustainable development goals and societal needs. The economic feasibility and cost-benefit analysis contribute to assessing the financial viability, profitability, and potential positive impacts of renewable energy-based smart microgrids.

They play a crucial role in determining the economic feasibility and providing a holistic understanding of the project's benefits and implications for rural electrification.

Table 16: Economic Feasibility Analysis

Parameter	Value(\$)
initial Investment	500,000
Annual Savings	50,000
Payback Period	10 years
Return on Investment	8%

The table provides key economic parameters, including the initial investment, annual savings, payback period, and return on investment, offering insights into the economic viability and profitability of the microgrid project

Table 17: Sensitivity Analysis-Economic Viability:

Parameter	Base Value(\$)	Sensitivity Analysis (\$)
Installation Cost	200,000	250,000
Operation Cost	30,000	35,000
Maintenance Cost	10,000	12,000

This table examines the impact of varying installation, operation, and maintenance costs on the economic viability of the microgrid, allowing for a sensitivity analysis and assessment of cost effectiveness

VII. Conclusion

Summary of Findings

In this research paper, we have designed and optimized a renewable energy-based smart microgrid for rural electrification. Through the analysis of the Simulink model under different load profiles, several key findings have been obtained. The load analysis revealed the varying electricity demand in rural areas, which influenced the sizing and selection of renewable energy sources. The integration of smart grid technologies and control strategies facilitated efficient energy management and improved system performance. The simulation results demonstrated the stability of the microgrid under different load variations and highlighted the effectiveness of energy management strategies in achieving energy savings. Additionally, the economic viability assessment showed promising results, with significant savings and reasonable payback periods.

Implications And Future Work:

The findings of this research have significant implications for rural electrification projects. The design and optimization of the renewable energybased smart microgrid offer a sustainable and reliable solution for providing electricity to underserved communities. The use of Simulink modeling and analysis has proven valuable in evaluating system performance and identifying areas for improvement. Future work could focus on further enhancing the control strategies and energy management algorithms to achieve even higher levels of efficiency and stability. Additionally, the integration of energy storage systems and advanced grid technologies can be explored to enhance the microgrid's capabilities. Furthermore, field trials and case studies can be conducted to validate the simulation results and gather real-world data to further refine and optimize the microgrid design. In conclusion, this research provides valuable insights into the design and optimization of renewable energy-based smart microgrids for rural electrification. The findings contribute to the development of sustainable energy solutions and pave the way for improved access to electricity in rural areas, ultimately improving the quality of life and promoting economic development.

ACKNOWLEDGMENT

The authors would like to acknowledge Integral University, Lucknow, for providing the MCN “IU/2D/ 2024 – MCN0002581”.

The statements made herein are solely the responsibility of authors.

REFERENCES

- [1] International Energy Agency (IEA).(2019).World Energy Outlook 2019. Retrieved from <https://www.iea.org/reports/world-energyoutlook-2019>

- [2] Farhan, M., Mohammed, O.A. , & Jiang, J.(2020).Overview of Microgrid Architectures, Applications, and Challenges. *Energies*, 13(3), 650.
- [3] Khatib, H., Singh, S.,& Pota, H.(2019). Microgrid Operation and Control: A Review. *IET Smart Grid*, 2(3), 216-225
- [4] Nara, K., Bhattacharya, K., & Chakraborty, C. (2020). A Comprehensive Review on Design and Control Aspects of Microgrid. In 2020 IEEE International Conference on Advanced Networks and Telecommunications Systems (ANTS) (pp. 1-6). IEEE.
- [5] Shao, Z., Hu, Z., He, L., Zhang, Q., & Yu, L. (2019). Microgrid: Modeling and Control Review. *IET Smart Grid*, 2(1), 1-9.
- [6] Siano, P. (2014). Demand Response and Smart Grids—A Survey. *Renewable and Sustainable Energy Reviews*, 30, 461-478
- [7] Xu, Y., Tan, H., Zhang, N., &He,W.(2021).Power Quality Enhancement Techniques in Microgrid: A Comprehensive Review. *IEEE Transactions on Industrial Informatics*, 17(3), 1953-1967.
- [8] Khan, A. A., Kiani, A. K., & Muhammad, M. (2020). Techno-economic feasibility of smallscale hydropower systems for rural electrification: A review. *Renewable and Sustainable Energy Reviews*, 133, 110258
- [9] . Kumar,D.,Kumar,N.,Rani,M.,&Dahiya,R.(2020) .SolarPhotovoltaicPowerSystems for Rural Electrification: A Comprehensive Review. *Renewable and Sustainable Energy Reviews*, 133, 110188.
- [10] Mollik, M. A. H., Sarwar, A., Rahaman, M. A., & Mekhilef, S. (2021). Integration of Renewable Energy Technologies in Microgrid Systems: A Review. *Renewable and Sustainable Energy Reviews*, 135, 110241.
- [12] Sarker, S., Hossain, M.I. , Kabir, H. ,Hossain, M.S.,& Huda,N.(2019). Biomass Energy for Rural Electrificationin Developing Countries: A Review of Current Issues and Future Perspectives. *Renewable and Sustainable Energy Reviews*, 107, 438-455
- [13] Zhu,Y.,He,Z.,Wang,H.,Cao,Y.,&Yang,D.(2021).WindEnergyApplicationinRural Areas: A Review. *Renewable and Sustainable Energy Reviews*, 146, 111010.
- [14] Kumar, S., Mishra, M., Al-Wassai, F. N., Kumar, S., & Soni, A. (2021). Role of Smart Microgrid in Rural Electrification and Sustainable Development: Challenges, Solutions, and Future Directions. *Journal of Cleaner Production*, 295, 126379.
- [15] . Li, J., Wu, J., Cui, J., & Xiao, F. (2020). A Review of Intelligent Control for Smart Microgrids. *Renewable and Sustainable Energy Reviews*, 131, 109937.
- [16] Ma, X., Xiao, Z., Li, Y., & Zhang, Q. (2021). Optimal Operation of Renewable-Based Microgrid with Energy Storage System. *IEEE Transactions on Power Systems*, 36(5), 3784- 3797
- [17] Wang, Z., Zhao, Z., Wang, L., & Lin, J. (2021). A Comprehensive Review of Smart Microgrid Demand Response: From Concept to Practice. *Renewable and Sustainable Energy Reviews*, 148, 111306.
- [18] Xu, W., Zhao, D., Hu, Z., Li, J., & Meng, K. (2022). Smart Microgrid Operation and Control: A Comprehensive Review. *IEEE Transactions on Smart Grid*, 13(1), 136-153
- [19] Dong, Z., Hu, Z., & Wang, J. (2021). Distributed Control Strategy for Microgrid with Power Converters Based on Small-Signal Modeling and Simulations. *IEEE Transactions on Smart Grid*, 12(5), 4730-4741.
- [20] . Ma, X., Xiao, Z., Li, Y., & Zhang, Q. (2021). Optimal Operation of Renewable-Based Microgrid with Energy Storage System. *IEEE Transactions on Power Systems*, 36(5), 3784- 3797.
- [21] Mohammed, O. A., Hasan, M. M., & Jiang, J. (2021). A Review of the State-of-the-Art Modeling and Simulation of Microgrids. *Energies*, 14(10), 2821. Wen, X., Su,H.,&Huang,X.(2022).Multi
- [22] . ObjectiveOptimizationDesignofMicrogrid Considerin Integration of Wind Power and Energy Storage. *IEEE Transactions on Energy Conversion*, 37(1), 299-309.
- [23] . Zhang, L., Chen, B., Zhao, Z., & Huang, Z. (2021). Simulink-Based Modeling and Simulation of Microgrids. *IEEE Access*, 9, 88296-88306
- [24] Al-Sumaiti, A.T., Elhassan, M.A., AlGhandoor, A. (2017). Design of a renewable energy-based microgrid for remote communities in Jordan. *Renewable Energy*, 114, 1354-1365.
- [25] Bacher, P., Huttner, S., Honselaar, M., & Auer, H. (2016).Design and optimization of a renewable energy-based microgrid for rural electrification in Tanzania. In 2016 IEEE PES Innovative Smart Grid Technologies Conference Europe (ISGT-Europe) (pp. 1-6). IEEE
- [26] . Bai, X., Yang, J., Li, H., Zhao, W., Zhang, L., & Tian, W. (2018).Optimal design and control of a renewable-energy-based microgrid for rural electrification in developing regions. *Applied Energy*, 228, 515-526.
- [27] Chatterjee, A., Mondal, S., Ghoshal, S.P., Saha, H.N., & Sinha, R. (2018).Design and optimization of renewable energy-based hybrid microgrid for rural electrification inIndia. *Journal of Cleaner Production*, 189, 283-298.
- [28] Chowdhury, S., Chowdhury, S.P., & Crossley, P.A. (2012).*Microgrids and Active Distribution Networks*. London: The Institution of Engineering and Technology.
- [29] Datta, P., & Chakrabarti, S. (2014). Simulation and optimization of a renewable energy based hybrid microgrid system for remote rural electrification. *Renewable Energy*, 61, 106- 115.

- [30] . Etezadi-Amoli, M., Mohsenian-Rad, A.H., & Wong, V.W. (2014). Optimal design of microgrids for commercial buildings. *IEEE Transactions on Smart Grid*, 5(2), 618-626
- [31] Ghatikar, G., Mashayekh, S., Stadler, M., & Greenberg, S. (2012). Distributed energy resources and microgrid modeling tools for sustainability impact assessments. *Applied Energy*, 96, 138-148
- [32] . Guerrero, J.M., Vasquez, J.C., Matas, J., & Castilla, M. (2013). Hierarchical control of droop-controlled AC and DC microgrids—A general approach toward standardization. *IEEE Transactions on Industrial Electronics*, 60(4), 1251-1265
- [33] Haesen, E., Driesen, J., Belmans, R., & D'Haeseleer, W. (2005). Microgrids and active distribution networks. *Proceedings of the IEEE*, 93(11), 1849-1857
- [34] Kalantar, M., & Dabbagh, S.A. (2019). A novel energy management system for a microgrid with demand response program in rural areas. *Sustainable Energy Technologies and Assessments*, 34, 92-103.
- [35] Kashefi-Kaviani, A., Haghifam, M.R., & Asghari-Moghaddam, A. (2014). A two-stage multi-objective approach for optimal sizing and placement of renewable energy resources considering uncertainties. *Applied Energy*, 113, 375-385.
- [36] Li, H., Yang, J., Bai, X., Zhang, L., & Tian, W. (2019). A comprehensive optimization framework for planning and operation of renewable-energy-based microgrid. *Applied Energy*, 242, 935-948.
- [37] Liu, C., Sun, Y., & Zhang, L. (2021). Load scheduling optimization of renewable energy based microgrid with considering demand response. *Sustainable Energy Technologies and Assessments*, 45, 101362
- [38] . Muttaqi, K.M., Agalgaonkar, A.P., & Perera, S. (2017). *Microgrids: Design, Implementation, and Applications*. New York: CRC Press.
- [39] . Nkwetta, D.N., Raison, B., & Dale, P.J. (2018). Design and optimization of an autonomous hybrid power system for remote telecommunications stations. *Applied Energy*, 212, 292-306.
- [40] Romano, P., Cacciato, M., Cosentino, V., Guaiana, S., & Massaro, F. (2021). A review on microgrid modeling: State-of-the-art and future research directions. *Energies*, 14(2), 301.
- [41] Siano, P. (2014). Demand response and smart grids—A survey. *Renewable and Sustainable Energy Reviews*, 30, 461-478.
- [42] Yang, J., Zhang, L., & Bai, X. (2020). Energy management strategies for renewable-energy-based microgrids: A comprehensive review. *Applied Energy*, 277, 115474.
- [43] Zhang, Y., Zhou, Y., Wu, T., Xiong, Y., & Zhang, J. (2018). Economic optimization of a renewable energy-based microgrid with demand response. *IEEE Transactions on Smart Grid*, 10(3), 2457-2466
- [44] Modeling and simulation of photovoltaic cell using single diode solar cell and double diode solar cell model* TA Chandel, MY Yasin, MA Mallick - *Int. J. Innovative Technol. Explor. Eng. (IJITEE)*, 2019
- [45] Performance Evaluation and Assessment of 100 kW Grid-Tied SPV System in Subtropical Climatic Conditions AF Minai, MA Siddiqui, SH Laskar, AA Khan... - *International Conference on Emerging Electronics and ...*, 2022
- [46] A new high-gain DC-DC converter with continuous input current for DC microgrid applications J Ahmad, M Zaid, A Sarwar, CH Lin, M Asim, RK Yadav... - *Energies*,