

<sup>1</sup> Tejas B.  
Maniar  
<sup>2</sup> Mansi P.  
Kothari  
<sup>3</sup> J. B. Sarvaiya  
<sup>4</sup> Mittal  
Parmar  
<sup>5</sup> Bhavik  
Chaudhari  
<sup>6</sup> Divyesh  
Parmar

## Application of DC-DC Converter for Grid Connected Inverter using PV Cell



**Abstract:** - The purpose of this paper is to provide general knowledge about photovoltaic (PV) cells. The modeling of photovoltaic cell is carried out to obtain typical I-V and P-V characteristics of photovoltaic cells. The voltage available at PV panel terminals is rapidly changing and for that it needs to processed constant voltage output. A boost converter use for step up the input voltage and keep output voltage constant. Photovoltaic array has an operating point and it's called maximum power point, which depending on cell temperature and the irradiation level and array voltage. The maximum power point tracking (MPPT) is needed to operate the PV array at its maximum power point. The maximum power point tracking is proposed utilizing a boost converter topology. Solar panel voltage and current are continuously observed by a closed loop microcontroller based control system and the duty cycles of the boost converter continuously adjust at maximum power. Various algorithms for MPPT are available. In this paper used the perturb-and-observe algorithms to achieved maximum power.

**Keywords:** PV cell, MPPT, DC-DC Boost converter.

### I. Introduction

Energy is the most important factor and basic requirement for our daily life. But due to increasing population coupled with global warming and reducing fossil resources, for produce electrical energy need of alternative renewable energy technologies based on wind, solar cell biomass etc. further, continuous increased technology for that to reduced product cost, increased in the scale of production of renewable energy products, renewable energy friendly government policies are catalyzing the growth of renewable energy [1][2].

In today's investment in solar photovoltaic energy (PV) is rapidly increasing worldwide [1]. Solar photovoltaic energy is a pollution free renewable energy sources wch attributes high durability and reliability. In PV capability of energy conversion without intermediate thermal process. [2]

In existing research, A circuit based system model of PV modules helps to analyze the performance of commercial PV modules. PV system shows Current-Voltage (I-V) and Power- Voltage (P-V) characteristics with different types of environmental and electrical parameters [2]. This paper presented the MATLAB simulation of PV cell that made prediction of performance the PV cell under different varying parameters such as solar radiation, ambient temperature, ideality factor, series and shunt resistance, combination of series and parallel solar cells. The model of PV cell is based on mathematical equation using basic blocks is developed in MATLAB/Simulink [3,4]. The change in insulation conditions also change efficiency and output power of PV modules.[5] To improve the efficiency and maintaining constant output power of PV modules Maximum power point tracking (MPPT) required[5]. In this paper most popular of MPPT technique perturb and observe (P&O) method will involved. This model can be used as a common system to analyze the performance of any PV modules by entering the required parameters[4,7].

<sup>1,2,3,4,5,6</sup> Assistant Professor, Department of Electrical Engineering

<sup>1,3</sup> Shantilal Shah Engineering College, Bhavnagar, Gujarat, India.

<sup>2</sup> Government Engineering College, Bhavnagar, Gujarat, India,

<sup>4</sup> Government Engineering College, Dahod, Gujarat, India,

<sup>5</sup> L.D. College of Engineering, Ahmedabad, Gujarat, India,

<sup>6</sup> Government Engineering College, Bharuch, Gujarat, India.

Copyright © JES 2024 on-line : journal.esrgroups.org

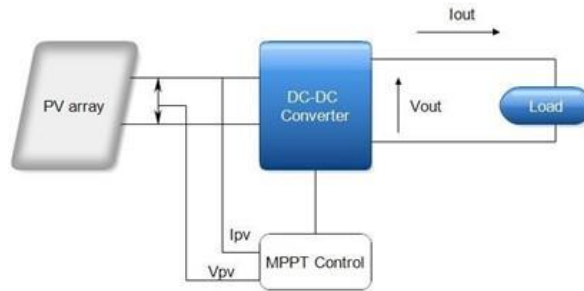

Figure 1. DC-DC converter for operation with MPPT This paper also focus on design of DC-DC boost converter and integration of DC-DC Boost converter with PV module using MPPT algorithms (P&O)[5]. In this paper also mention about hardware of DC-DC converter using PV modules.

This paper organized as follows: Section I gives the Introduction to the PV module and MPPT. Section II gives the PV array Introduction. Section III gives the DC-DC Converter Information. Section IV gives the MPPT algorithms. Section V and VI gives the Simulation results and the conclusion respectively.

II. PV ARRAY

A Solar cell generally is a p-n semiconductor junction. When light exposed to it is generated DC current[2,6,9]. The generated DC current changed linearly with the solar irradiance [4]. The power generated by a single solar cell is very low. So, solar cells are connected in series or parallel combination for more power[1-3,6,8]. The equivalent circuit of an ideal solar cell shown in figure 2.

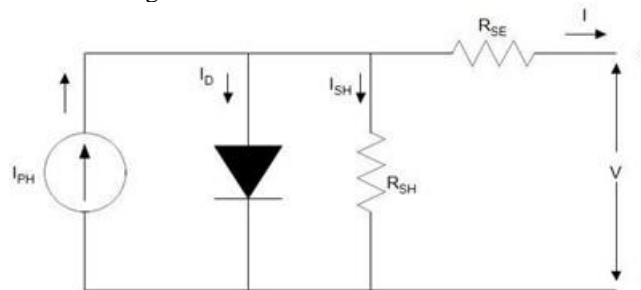

Figure 2. General model of solar cell

A general model of the solar cell is current source ( $I_{PH}$ ) connected in anti-parallel with a diode (D), series resistance ( $R_{SE}$ ) and shunt resistance ( $R_{SH}$ ).

I-V and P-V characteristics of Solar cell are shown in figure 3. The PV cell produced maximum power at only one point is called maximum power point (MPP)[3,4,7]. Maximum current maximum voltage and the maximum power of the PV cell is  $I_m, V_m$  and  $P_m$  respectively.

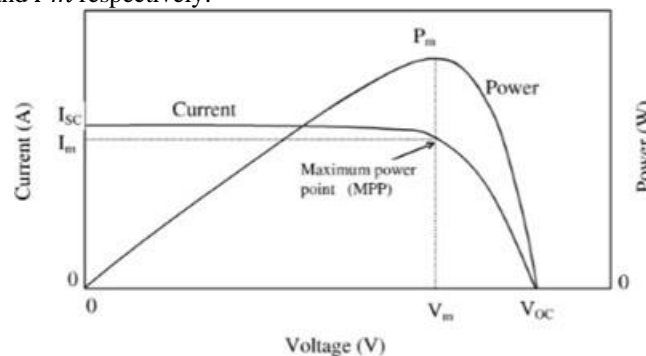

Figure 3. I-V and P-V Characteristics of solar cell

The mathematical equation for output current of ideal cell [1-4].

$$I = I_{PH} - I_D \tag{1}$$

Where,

$I_{PH}$  is the light generated current

$I_D$  is the Shockley equation.

The PV generated current is depends on solar irradiation and its working temperature is,

$$I_{PH} = [I_{SC} + K_I(T_C - T_{REF})].G \tag{2}$$

Where,

$I_{SC}$  = short circuit current of PV cell at 25°C temperature and  $G = 1$ ,

$K_I$  = short-circuit current temperature co-efficient of cell,

$T_C$  = operating temperature of cell  
 $T_{REF}$  = reference temperature of cell  
 The Shockley equation

$$I_D = I_S \left\{ \exp\left(\frac{qV}{AKT_C}\right) - 1 \right\} \quad (3)$$

Where,  
 $I_S$  = saturation or leakage current of diode  
 $q$  = electron charge [ $1.60 \times 10^{-19}$  oC]  
 $K$  = Boltzmann constant [ $1.38 \times 10^{-23}$ J/K]  
 $A$  = Ideality factor of diode

Based on general model, the output current of PV cell can be defined as

$$I = I_{PH} - I_D - I_{SH} \quad (4)$$

$$I = I_{PH} - I_S \left\{ \exp\left(\frac{qV}{AKT_C} + IR_{SE}\right) - 1 \right\} - \frac{V + IR_{SE}}{R_P} \quad (5)$$

For the Analysis of PV the value of ' $R_p$ ' is neglected because is extremely high. The appropriate model of PV cell [4] is shown in figure 4. Re written the equation (5)

$$I = I_{PH} - I_S \left\{ \exp\left(\frac{qV}{AKT_C} + IR_{SE}\right) - 1 \right\} \quad (6)$$

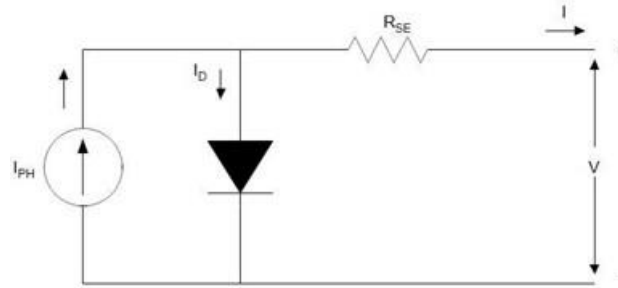

Figure 4. Appropriate model of solar cell

The PV cell generally connected in series or parallel for obtain the desired output voltage and current the mathematical equation for the PV array of simple model with series and parallel connected modules can be described

$$I = I_{PH} N_P - I_{S_P} N_P \left\{ \exp\left(\frac{qV}{AKT_C N_S} + \frac{IR_{SE}}{N_P}\right) - 1 \right\} \quad (7)$$

Where,  
 $N_P$  &  $N_S$  = number of modules connected in parallel and series respectively.  
 The diode saturation current of cell varies with the cell temperature which can expressed [2,] as,

$$I_S = I_{S0} \exp\left[\frac{qE_G}{kA} \left(\frac{1}{T_{ref}} - \frac{1}{T_C}\right)\right] \quad (8)$$

Where,  
 $I_{RS}$  = reverse saturation current of cell  
 $E_G$  = band gap energy of the semiconductor  
 Using equation (9), the reverse saturation current of cell at reference temperature of 250C can be calculated.

$$I_{RS} = \frac{I_{SC}}{\exp\left(\frac{qV_{oc}}{N_S K A T_C}\right) - 1} \quad (9)$$

### III. DC-DC CONVERTER

Basically DC-DC converter is step up or step down the voltage that given in input of DC converter[2,8]. There are different types of DC-DC converter like Buck, Boost, Buck-boost, Cuck, Sepic etc. In here using for step up the voltage that's why using Boost converter, Boost converter convert DC low voltage to high voltage. DC-DC boost converter used for regulate the voltage generated by PV cell[2]. The equivalent circuit diagram of DC-DC boost converter is shown in figure 5.

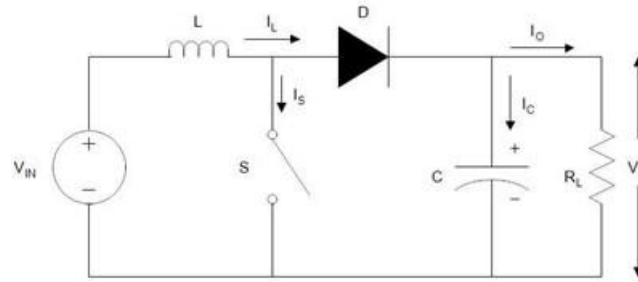

Figure 5. Equivalent Circuit of Boost converter

The boost converter output voltage is depends on the duty cycle of control switch (MOSFET,IGBT)[8]. If change the ON time of switch then change in output voltage, for the duty cycle “D” average output voltage can be calculated using

$$\frac{V_O}{V_{IN}} = \frac{1}{1-D} \quad (10)$$

Where,

$V_{IN}$  = input voltage of converter

$V_O$  = output voltage of converter

D = duty cycle of control switch

The inductor and capacitor value are calculated using the formula[5].

Equation of Inductor value of the boost converter

$$L = \frac{V_{IN}}{(f_L \Delta I_L)} \quad (11)$$

Where,

$f_L$  = switching frequency

$\Delta I_L$  = input current ripple

The ratio between input current ripple and output current is called current ripple factor. Estimation of good inductor value of current ripple factor should bound within 30 %, the current rating of inductor is always higher than maximum output current[2,5,8].

Equation of Capacitor value of the boost converter

$$C = \frac{I_O}{(f_S \Delta V_O)} \quad (12)$$

Where,

$\Delta V_O$  = output voltage ripple which usually considered as 5 % of output voltage.

#### IV. MAXIMUM POWER POINT TRACKING

Directly connected PV system do not operate at the maximum power point significant amount of available energy are wasted, for that a DC-DC converter required to better match the PV generation[6]. A PV array will have operate one point on its I-V and P-V characteristics that point called MPP, the MPP changed with changing the temperature and irradiation, for that tracking of that MPP is called Maximum power point tracking(MPPT)[4,6]. Perturb and Observe (P&O) algorithm used for tracking the MPP, flow chart of P&O algorithm shown in figure 6.



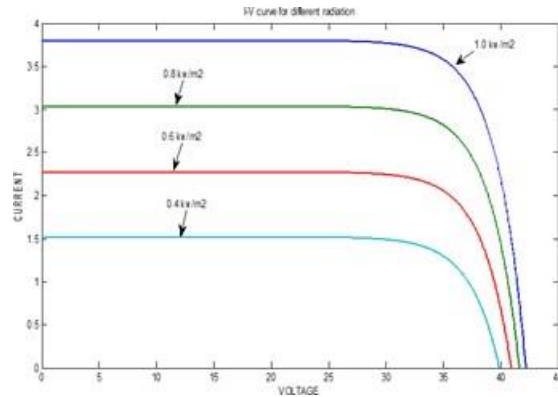

Figure 8(a) I-V characteristics curves at different irradiation level and constant temperature ( $T = 25^{\circ}\text{C}$ )

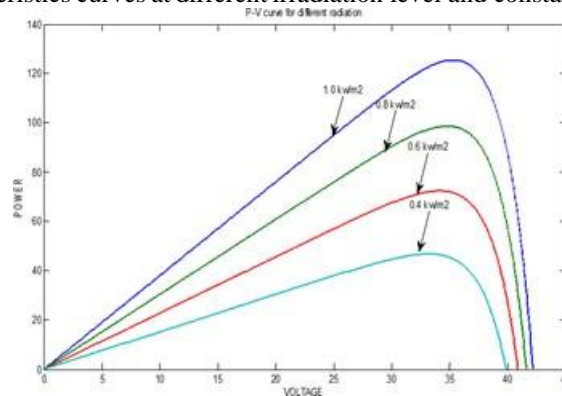

Figure 8(b) P-V characteristics curves different irradiation level and constant temperature ( $T = 25^{\circ}\text{C}$ )

Figure 9(a) and 9(b) shows the I-V and P-V characteristics curves of PV module obtained from the simulation with different temperature levels and constant irradiation ( $G = 1000 \text{ Wb}/\text{m}^2$ ).

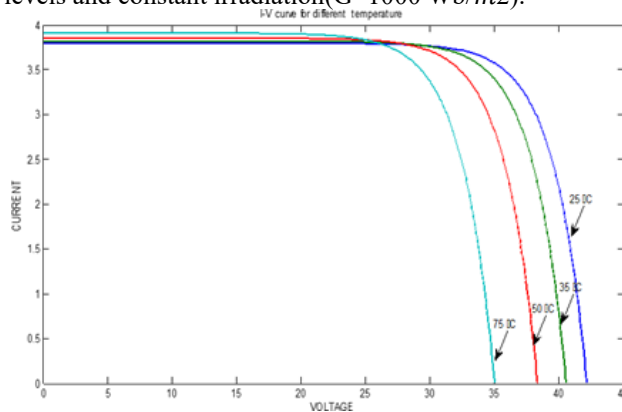

Figure 9(a) I-V characteristics curves at different temperature and constant irradiation ( $G = 1000 \text{ Wb}/\text{m}^2$ )

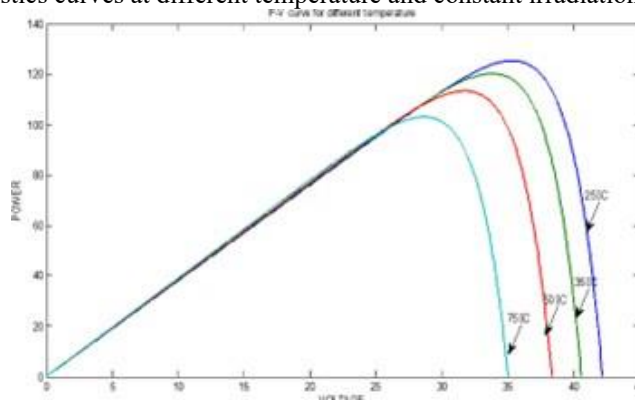

Figure 9(b) P-V characteristics curves at different temperature and constant irradiation ( $G = 1000 \text{ Wb}/\text{m}^2$ )

B. Simulation of PV module with DC-DC Boost converter

Figure 10 shown the MATLAB Simulation of PV module with DC-DC boost converter. Here sub system of PV module with P&O MPPT algorithm for achieving maximum power point, give the duty cycle “D” to switch, in this simulation MOSFET used as a switch. Boost converter using for step up the input voltage.

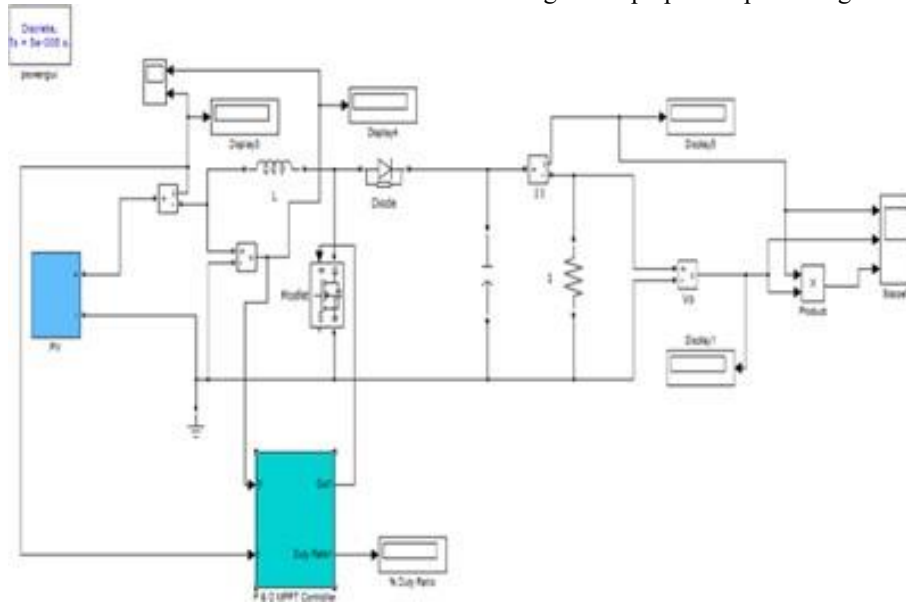

Figure.10. PV fed DC-DC Boost converter

In this model PV module output voltage and current is 41.1 volt and 1.0 ampere respectively, this output voltage and current of PV module is input for Boost converter; then the boost converter convert voltage and current at 55.2 volt and 0.72 ampere respectively.

Figure 11(a) shows Input voltage and Output voltage of PV fed Boost converter and figure 11(b) shows Input and Output current respectively.

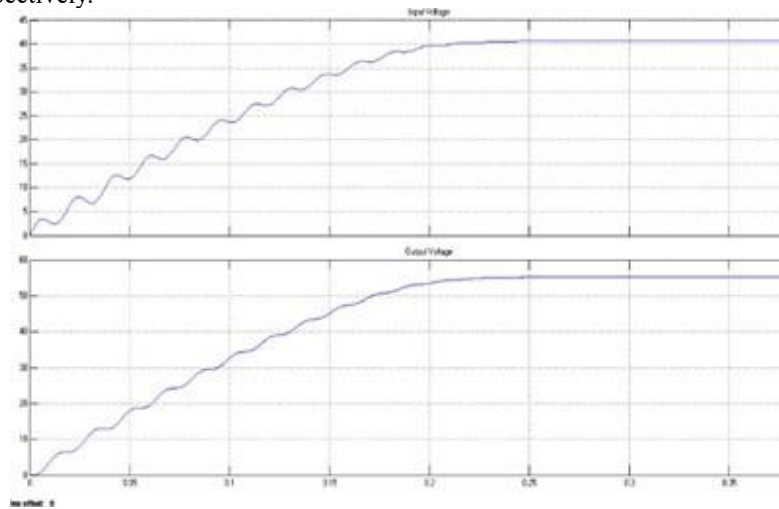

Figure 11(a). Input voltage and output voltage of PV fed Boost converter

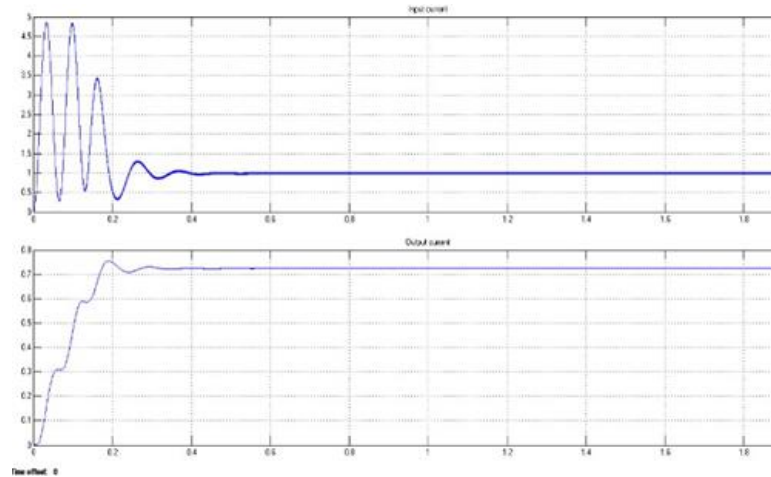

Figure 11(b). Input current and output current of PV fed Boost converter

## VI. CONCLUSION

This paper presents a general circuit and appropriate system of PV cell help to analyze the performance of PV modules. A general model of PV module developed using mathematical equation in the form of sub system block in MATLAB. The model can give the I-V and P-V Curve characteristics for different radiations and temperature levels of PV modules.

In this paper, The Simulated of mathematical model of PV fed Boost Converter with P and O MPPT algorithm and the result obtained from the constant DC input supply. also see the result of input/output voltage and input/output current of PV fed boost converter.

## REFERENCES

- [1] S. Li and H. Zheng, "Energy extraction characteristic study of solar photovoltaic cells and modules," *2011 IEEE Power and Energy Society General Meeting*, San Diego, CA, 2011, pp. 1-7.
- [2] S. S. Mohammed and D. Devaraj, "Simulation and analysis of stand-alone photovoltaic system with boost converter using MATLAB/Simulink," *2014 International Conference on Circuits, Power and Computing Technologies [ICCPCT-2014]*, Nagercoil, 2014, pp. 814-821.
- [3] M. F. Nayan and S. M. S. Ullah, "Modelling of solar cell characteristics considering the effect of electrical and environmental parameters," *2015 3rd International Conference on Green Energy and Technology (ICGET)*, Dhaka, 2015, pp. 1-6.
- [4] J. Chauhan, P. Chauhan, T. Maniar and A. Joshi, "Comparison of MPPT algorithms for DC-DC converters based photovoltaic systems," *2013 International Conference on Energy Efficient Technologies for Sustainability*, Nagercoil, 2013, pp. 476-481.
- [5] H. Lee, M. J. Lee, S. N. Lee, H. C. Lee, H. K. Nam and S. J. Park, "Development of photovoltaic simulator based on DC-DC converter," *INTELEC 2009 - 31st International Telecommunications Energy Conference*, Incheon, 2009, pp. 1-5.
- [6] M. Marodkar, S. Adhau, M. Sabley and P. Adhau, "Design and simulation of DC-DC converters for Photovoltaic system based on MATLAB," *2015 International Conference on Industrial Instrumentation and Control (ICIC)*, Pune, 2015, pp. 1478-1483.
- [7] R. Gules, J. D. P. Pacheco, H. L. Hey and J. Imhoff, "A Maximum Power Point Tracking System With Parallel Connection for PV Stand-Alone Applications," in *IEEE Transactions on Industrial Electronics*, vol. 55, no. 7, pp. 2674-2683, July 2008.
- [8] B. M. Hasaneen and A. A. Elbaset Mohammed, "Design and simulation of DC/DC boost converter," *2008 12th International Middle-East Power System Conference*, Aswan, 2008, pp. 335- 340.
- [9] G. Bhuvaneshwari and R. Annamalai, "Development of a solar cell model in MATLAB for PV based generation system," *2011 Annual IEEE India Conference*, Hyderabad, 2011, pp. 1-5.