

¹ Dr K Sebasthirani
² Dr P Maruthupandi
³ M Manimegalai
⁴ N Silambarasan
⁵ R Mukil Vannan
⁶ C Venkatesh

Implementation of AI Tuned PID Controller for Speed and Direction Control of BLDC Motor



Abstract: - This paper explores BLDC motor control using MATLAB Simulink, focusing on AI tuned PID and fractional PID controllers for closed-loop speed regulation and direction. It involves designing a feedback system comprising sensor feedback, controller, and BLDC motor model. Through iterative tuning, optimal controller parameters are determined for enhanced performance. Simulations were carried out to evaluate response characteristics, stability, and robustness across varying conditions. Experimental validation through hardware-in-the-loop experiments corroborates simulation findings. Performance metrics, including speed accuracy and disturbance rejection, are analyzed to compare the effectiveness of PID and fractional PID controllers. This work provides insights into advanced control techniques for BLDC motors, aiding in the selection of suitable strategies for real-world applications.

Keywords: BLDC Motor, AI tuned PID controller, fractional controller, MATLAB Simulink.

I. INTRODUCTION

Dynamic Load Variations: Develop a control system capable of adapting to dynamic changes in load conditions to maintain consistent and desired motor speed. This includes addressing sudden acceleration, deceleration, and varying torque requirements. Sensor Integration: Implement a reliable sensor system for accurate feedback on motor speed, considering options such as Hall effect sensors, encoders, or advanced sensorless control techniques. Ensure robust performance even in the presence of sensor failures or disturbances. Core Control Algorithm Optimization: Devise a control algorithm that combines precision and responsiveness, minimizing overshooting and settling time. Explore advanced control strategies such as proportional Integral Derivative [PID] control, Fuzzy logic, for improved performance. Energy Storage Solution

Efficient control of Brushless DC (BLDC) motors is crucial for various industrial and automotive applications, where precise speed and direction regulation are essential. However, conventional speed control methods often exhibit limitations, leading to suboptimal performance and system inefficiencies. Common flaws in BLDC motor speed control include inadequate response to disturbances, difficulty in achieving precise speed regulation, and challenges in maintaining stability under varying loads and operating conditions. To address these shortcomings, this study focuses on the implementation of advanced control techniques using MATLAB Simulink, specifically examining the efficacy of PID and fractional PID controllers. By leveraging the capabilities of these controllers within a closed-loop feedback system, we aim to mitigate the inherent limitations of traditional BLDC motor control methods. Through comprehensive analysis and experimentation, this research seeks to elucidate how PID and fractional PID controllers can rectify the flaws associated with BLDC motor speed control. By optimizing controller parameters and leveraging advanced control strategies, we anticipate achieving improved speed accuracy, faster response times, enhanced disturbance rejection, and greater overall system stability.

¹ Department of Electrical and Electronics Engineering, Sri Ramakrishna Engineering College, Coimbatore, Tamil Nadu, India. sebasthirani.kathalingam@srec.ac.in

² Department of Electrical and Electronics Engineering, Government College of Technology, Coimbatore, Tamil Nadu, India. pandi@gct.ac.in

³ Department of Information and Technology, National Engineering College, Kovilpatti, Tamil Nadu, India. Manimegali_it@nec.edu.in

⁴ Department of Electrical and Electronics Engineering, Sri Ramakrishna Engineering College, Coimbatore, Tamil Nadu, India. Silambarasan.2003126@srec.ac.in

⁵ Department of Electrical and Electronics Engineering, Sri Ramakrishna Engineering College, Coimbatore, Tamil Nadu, India. Mukilvannan.2003146@srec.ac.in

⁶ Department of Electrical and Electronics Engineering, Sri Ramakrishna Engineering College, Coimbatore, Tamil Nadu, India. Venkatesh.2003142@srec.ac.in

II. LITERATURE SURVEY

In the field of BLDC Motor speed control via PID controller, several research papers have been discussed. Some of these are outlined a new speed control procedure for BLDC (Brushless DC) motor. This strategy is based on an improved PID (Proportional-Integral-Derivative) algorithm. The authors proposed enhancements to the traditional PID algorithm to achieve better speed control performance. Their research contributes to the advancement of BLDC motor control methodologies, potentially leading to improved efficiency and performance in various applications[1]. They focused on advancing the speed control system for BLDC (Brushless DC) motors by employing an adaptive fuzzy PID algorithm. This research, presented at the 2022 explored the integration of fuzzy logic with the traditional PID control method. By incorporating fuzzy logic, the control system gains adaptability to varying operating conditions, enabling it to adjust parameters dynamically. This adaptive approach enhances the system's ability to maintain precise speed control and responsiveness in real-time. The study adds to the field by offering a clever control methodology that consolidates the qualities of both PID control and fuzzy logic, potentially improving the performance and efficiency of BLDC motor systems across diverse applications.[2] a study on the plan and execution of a fuzzy logic PID controller for BLDC (Brushless DC) engine drives. This exploration PC and Correspondence Innovations. The authors focused on developing a controller that integrates both Fuzzy Logic and PID control methodologies. By combining these approaches, the controller gains the ability to adapt to varying operating conditions and achieve precise speed control of BLDC motors. The study contributes to the advancement of control strategies for BLDC motor drives, potentially enhancing their performance and efficiency across a range of applications.[3]. To improve on the strength of BLDC engines, the primary difficulties, for example, adaptation to non-critical failure, Electromagnetic obstruction, acoustic clamor, force wave, and transition wave ought to be controlled. Accordingly, the controlling strategies are examined in this paper Since BLDC engines are utilized in powerful applications, Unwavering quality control methods of engine drives are fundamental. Dependability control procedures like issue open minded control (FTC), electromagnetic obstruction control (EMI), and acoustic commotion control work on the achievability of the engine drive frameworks in powerful applications. [4][14] PID parameter self-tuning for Brushless DC (BLDC) motors using an improved GA-BP (Genetic Algorithm-Backpropagation) algorithm. The authors focused on developing an innovative method for automatically tuning the parameters of PID controllers, leveraging the combined power of genetic algorithms and backpropagation techniques. By utilizing this approach, the control system gains the ability to adaptively adjust PID parameters based on real-time feedback, optimizing motor performance under varying operating conditions. [5][7] This research contributes to the advancement of PID control strategies for BLDC motors, offering a self-tuning mechanism that enhances efficiency, responsiveness, and robustness in motor control applications.

III. EXISTING SYSTEM

The existing BLDC motor control system functions by receiving commands from the user interface or external control system and translating them into specific motor speed and direction outputs. Here's how it typically operates: **User Input:** Users input commands or set desired parameters (such as speed and direction) through the user interface or external control system. **Sensor Feedback:** Sensors, such as Hall effect sensors or encoders, provide feedback on motor speed and position to the control unit. This feedback is essential for closed-loop control and maintaining the desired motor performance. **Control Algorithm Execution:** The control unit executes the PID control algorithm, which calculates the appropriate motor control signals based on the changes between the predetermined setpoints and the actual motor speed. These control signals are then sent to the motor driver. **Motor Driver Operation:** The motor driver amplifies and modulates the control signals from the control unit to drive the BLDC motor. It controls the current and voltage supplied to the control the motor speed and direction. **Motor Operation:** The BLDC motor responds to the control signals by rotating at the specified speed and direction. The motor's actual speed and position are continuously monitored and fed back to the control unit for closed-loop control.[9]

Issues in the Existing System:

Manual PID Tuning: One of the main flaws is the manual tuning of PID parameters, which can be time-consuming and challenging, especially for dynamic systems like BLDC motors. This approach may lead to suboptimal performance and inefficiency under varying load conditions. **Limited Adaptability:** The existing system may lack adaptability to changing operating conditions, such as sudden load variations or

disturbances.[12] Traditional PID control may struggle to maintain stable performance in such scenarios, resulting in speed deviations or oscillations. Complexity and Cost: The system's complexity and cost may be higher due to the need for additional components such as sensors, motor drivers, and control units. This can pose challenges for budget-constrained applications or environments where simplicity is preferred. EMI Interference: Electromagnetic interference (EMI) generated during motor operation may pose reliability and safety concerns, especially in sensitive electronic environments. The existing system may require additional EMI filtering and shielding measures to mitigate these effects. Scalability Limitations: While the existing system may work well for specific motor sizes and applications, it may face limitations in scalability for larger or more demanding setups. Adapting the system to different motor specifications or requirements may require significant modifications or redesigns.

IV. PROPOSED SYSTEM

In this proposed system for BLDC motor speed control encompasses precise speed regulation, bidirectional rotation capability, and real-time monitoring through a Simulink model. Leveraging sensor feedback, the controller ensures that the motor's actual speed aligns with the set speed, with a maximum threshold of approximately 300 RPM[set speed for this project], automatically adjusting if it exceeds this limit. Additionally, the system allows for seamless direction control, enabling users to switch between forward and reverse rotation as needed. Operating at voltages above 40 volts, the system guarantees robust performance and efficiency across diverse applications, including electric vehicles, industrial automation, and consumer electronics. Through a unified interface in Simulink, users can visualize and manipulate both speed and direction control parameters, facilitating intuitive system management and optimization.

Conventional PID controllers have been widely employed for motor speed control due to their simplicity and effectiveness. However, tuning PID parameters manually can be challenging and time-consuming, especially in dynamic and nonlinear systems like BLDC motors. To address this limitation, an AI-based tuning method is proposed, leveraging machine learning algorithms to automatically optimize the PID controller parameters .

The Proposed AI-tuned PID controller is trained by dataset generated through simulations and experimental data. The training process involves the use of advanced optimization algorithms, such as genetic algorithms or particle swarm optimization, to find the optimal set for PID parameters that minimize the speed control error and enhance the system's overall stability.

The effectiveness of the AI-tuned PID controller is evaluated through comprehensive simulations and practical experiments on a BLDC motor setup. Comparative analyses with conventional PID controllers and other tuning methods highlight the superior performance of the proposed approach in terms of speed regulation, disturbance rejection, and response time. The results demonstrate that the AI-tuned PID controller not only simplifies the tuning process but also significantly improves the speed control precision of BLDC motors under varying operating conditions. .

V. BLOCK DIAGRAM

The proposed block diagram is shown in figure 1 depicts the intricate connections and components essential for implementing an AI-tuned PID controller for speed and direction control of a BLDC motor. At the heart of the system lies the BLDC motor, linked to a motor driver, which in turn connects to an Atmega 2560 microcontroller. This Atmega 2560 receives predetermined speed and direction setpoints from MATLAB Simulink, orchestrating the control process effectively. The actual speed and

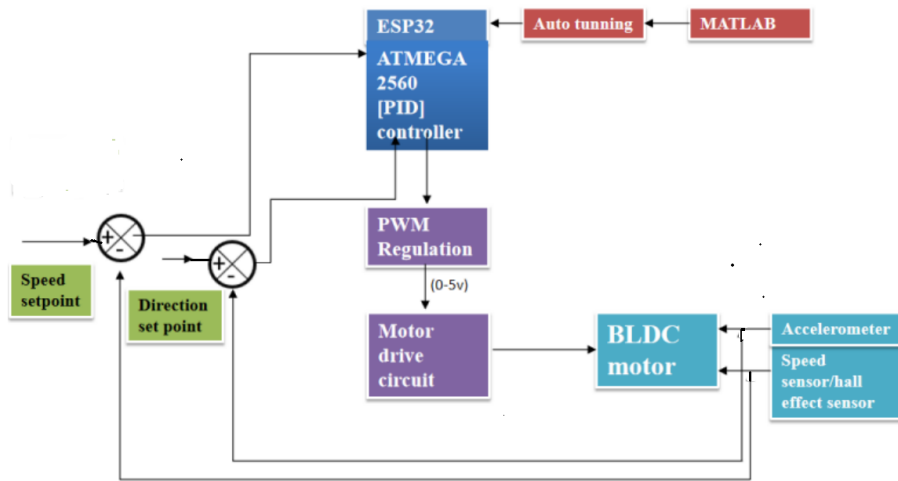

Figure: 1 Block diagram of the Proposed System

Of the BLDC motor collected by sensors which then sent to compare it with the actual set speed and if the difference exceed far beyond the set speed then the speed is automatically reduced to set speed or below it. The integrated system ensures seamless communication and coordination between the user interface, microcontroller, Simulink model, motor driver, and BLDC motor, ultimately enabling precise speed control and bidirectional rotation as per the user's requirements.

VI. WORKING

A. The User Interface (UI)

The User Interface (UI) serves as the point of interaction between the user and the BLDC motor speed control system. It allows users to input desired speed setpoints and control commands easily. Additionally, the UI provides feedback on the system's status and operation, enabling users to monitor the motor's performance in real-time. With its intuitive design, the UI facilitates straightforward system management and control, empowering users to adjust parameters as needed to meet specific requirements. Overall, the UI enhances the user experience by simplifying interaction with the system and providing essential information on system operation.

B. ATmega2560 Microcontroller

The ATmega2560 microcontroller serves as the central control unit of the BLDC motor speed control system. Its primary function is to process user inputs, execute control algorithms, and coordinate communication between various system components. The microcontroller receives input from the user interface, such as speed setpoints and control commands, and translates them into control signals for the motor driver. It also communicates with other system components, such as sensors and the Matlab Simulink model, to exchange data and ensure seamless operation. With its real-time control and monitoring capabilities, the ATmega2560 microcontroller plays an important role in orchestrating the overall functionality for the system and optimizing motor performance..

C. Matlab Simulink Model:

The Matlab Simulink Model is a software-based platform utilized for implementing advanced control algorithms. Its primary function is to execute sophisticated control strategies to regulate motor speed accurately. Key features of the Simulink model include: **Advanced Control Algorithm Implementation:** The Simulink model can implement complex control algorithms such as PID (Proportional-Integral-Derivative) control or other advanced strategies to achieve precise speed regulation of the BLDC motor. **Feedback Signal Processing:** It receives feedback signals from sensors, such as Hall effect sensors or encoders, to monitor the motor's actual speed and position. **Generation of Control Signals:** Based on the input received from the user interface and the feedback from sensors, the Simulink model generates control signals. These signals are then sent to the motor driver to adjust the motor's speed and direction as necessary. Overall, the Matlab Simulink Model serves as a vital component in implementing closed-loop control for the BLDC motor, ensuring that the motor's actual speed closely follows the desired setpoints provided by the user. It enables precise control and optimization of motor performance in various operating conditions

D. Motor Driver

The Motor Driver plays a pivotal role in the BLDC motor speed control system by translating control signals into appropriate power outputs for the motor. Its primary function encompasses both amplification and modulation of control signals, ensuring that the low-power signals from the microcontroller are boosted to levels suitable for driving the BLDC motor effectively. Through modulation, the motor driver regulates the current and voltage supplied to the motor, enabling precise control over its speed and torque characteristics.

This modulation capability is essential for achieving smooth and accurate motor operation across various operating conditions. Additionally, the motor driver offers bidirectional control capability, allowing the motor to rotate in both forward and reverse directions as needed. This versatility enhances the system's flexibility and applicability to different tasks and environments. Moreover, the motor driver is designed for efficient and reliable operation, with built-in protections against overcurrent, overvoltage, and other potential faults. By ensuring stable power delivery and safeguarding against electrical anomalies, the motor driver enhances the overall reliability and longevity of the BLDC motor speed control system.

E. BLDC Motor

The BLDC Motor lies at the heart of the BLDC motor speed control system, serving as the crucial component responsible for converting electrical energy into mechanical motion. Its primary function is to translate the electrical power supplied by the motor driver into rotational movement, enabling the motor to drive various mechanical systems and devices. With precise control signals from the motor driver, the BLDC motor rotates at the specified speed and direction, catering to the specific requirements of the application. This responsiveness ensures smooth and accurate operation, allowing the motor to perform tasks with precision and efficiency. Additionally, the BLDC motor is engineered for reliability and efficiency, offering consistent performance over prolonged periods. Its robust design minimizes wear and tear, resulting in reliable operation and reduced maintenance needs. Furthermore, within the motor driver circuitry, the PWM signal is employed for precise speed control. By modulating the duty cycle of the PWM signal, the motor driver regulates the average voltage applied to the BLDC motor, further enhancing speed control and overall system efficiency. Together, these features make the BLDC motor a critical component in various applications, ranging from electric vehicles to industrial automation, where precise control and reliable operation are paramount.

F. PWM Technique

In the BLDC motor speed control project, PWM (Pulse Width Modulation) plays a crucial role in regulating the average voltage supplied to the BLDC motor. Within the motor driver circuitry, PWM signals are utilized to modulate the power delivered to the motor windings, allowing for precise control over motor speed and direction. The PWM signals generated by the motor driver are adjusted based on the control commands received from the ATmega2560 microcontroller, which processes user inputs and executes control algorithms. By varying the duty cycle of the PWM signals, the motor driver regulates the amount of time the voltage is applied to the motor, effectively controlling the speed and torque output. This modulation technique enables the BLDC motor to operate efficiently and responsively, responding quickly to changes in speed setpoints and maintaining consistent performance under varying load conditions. Additionally, PWM helps minimize power losses and heat generation in the motor driver circuitry, enhancing overall energy efficiency and system reliability. Overall, PWM plays a critical role in the BLDC motor speed control system by providing precise and efficient control over motor operation, contributing to the project's objectives of achieving accurate speed regulation and optimal performance.

G. Sensor

The Hall effect sensor, a key component in the BLDC motor speed control system, detects changes in magnetic fields to determine the motor's rotational position. It operates by generating a voltage proportional to the magnetic field strength, allowing for accurate position sensing without physical contact. The sensor provides real-time feedback on the motor's position to the ATmega2560 microcontroller, enabling precise control algorithms to adjust motor speed and direction accordingly. With its non-contact operation and reliability, the Hall effect sensor enhances the system's performance and responsiveness, ensuring smooth and efficient motor operation in various applications.

VII. HARDWARE SETUP

In the hardware setup, as shown in Figure 2, the BLDC motor is connected to the motor driver, which receives control signals from the ATmega2560 microcontroller. The microcontroller also interfaces with the user interface, enabling users to input speed setpoints and control commands. Additionally, the microcontroller communicates with the Matlab Simulink model to exchange data and generate control signals based on sensor feedback. The Hall effect sensor provides real-time feedback on the motor's position to the microcontroller, completing the feedback loop for precise control. Finally, all components are powered by a suitable power source, ensuring proper operation of the entire system. This interconnected setup enables the microcontroller to regulate motor speed and direction accurately based on user inputs and sensor feedback, facilitating efficient and responsive control of the BLDC motor.



Figure: 2 Hardware Setup

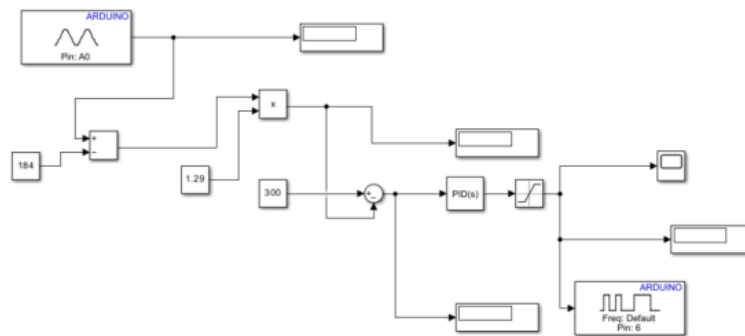

Figure :3 Simulink Model

VIII. OPERATION

The Implementation of AI tuned PID controller for Speed and Direction control of BLDC motor, we ensure precise speed regulation, bidirectional rotation, and real-time monitoring through a Simulink model. By leveraging sensor feedback, our controller ensures that the motor's actual speed closely matches the desired set speed, with a maximum threshold typically set at around 300 RPM. When the system is activated, the user inputs the desired speed and direction parameters via the Simulink interface as shown in Figure 3. The ATmega2560 microcontroller processes these inputs and generates corresponding control signals. These signals are then transmitted to the motor driver, which amplifies and modulates them to drive the BLDC motor effectively. Simultaneously, the system continuously monitors the motor's actual speed using feedback from sensors, such as Hall effect sensors. If the actual speed deviates from the set speed, the control algorithm implemented in the Simulink model automatically adjusts the control signals sent to the motor driver. This adjustment brings the

motor's speed back within the desired range, ensuring precise speed regulation. Additionally, our system allows for seamless direction control, enabling users to switch between forward and reverse rotation as needed. This capability enhances the versatility of the system, making it suitable for a wide range of applications. Operating at voltages above 40 volts, our system guarantees robust performance and efficiency across diverse applications. The higher voltage capability ensures that the motor can handle demanding tasks while maintaining optimal performance. Through the unified interface provided by Simulink, users can visualize and manipulate both speed and direction control parameters. This intuitive interface facilitates system management and optimization, allowing users to fine-tune the motor's operation to meet specific requirements. Overall, the operation of our BLDC motor speed control system involves precise regulation of speed and direction, facilitated by real-time monitoring and control algorithms implemented in Simulink.

IX. OUTPUT

The Output section displays Implementation of AI tuned PID controller for Speed and Direction control of BLDC motor is shown in Figure 4. User Interface (UI) serves as the point of interaction between the user and the BLDC motor speed control system. It allows users to input desired speed setpoints and control commands easily

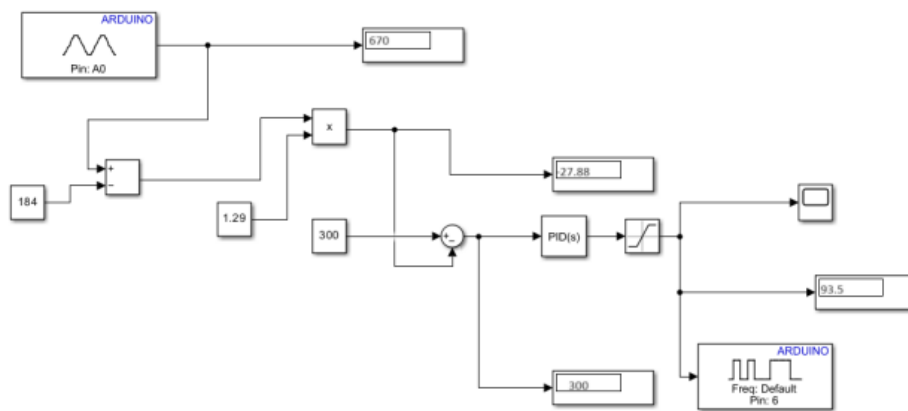

Figure : 4 Output

The output of the proposed system BLDC motor speed control going over 300 rpm as the speed starts to reduce, emphasizing precise regulation, bidirectional rotation, and real-time monitoring capabilities. Through simulations and hardware-in-the-loop experiments, the system demonstrates its effectiveness in achieving accurate speed control, seamless direction switching, and robust performance across various operating conditions. Performance metrics such as speed accuracy and disturbance rejection are analyzed to validate the system's effectiveness, providing valuable insights into advanced control techniques for BLDC motors. Overall, the output highlights the system's potential for real-world applications, offering a reliable and efficient solution for motor control needs.

X. CONCLUSION

In the proposed system for Brushless DC (BLDC) motor speed control offers a comprehensive solution aimed at achieving precise speed regulation, bidirectional rotation capability, and real-time monitoring through a unified platform. By integrating key components such as the ATmega2560 microcontroller, Matlab Simulink model, motor driver, and BLDC motor, the system ensures efficient operation and robust performance across diverse applications. Through the user interface, users can easily input desired speed setpoints and control commands, facilitating intuitive system management. The ATmega2560 microcontroller serves as the central control unit, processing user inputs, executing control algorithms, and communicating with other system components. The Matlab Simulink model implements advanced control algorithms for speed regulation, incorporating feedback signals from sensors to adjust control signals dynamically. This enables precise alignment between the actual motor speed and the set speed, with bidirectional rotation capability and automatic adjustments to ensure compliance with predetermined speed thresholds. The motor driver plays a crucial role in amplifying and modulating control signals from the Simulink model, driving the BLDC motor to achieve the desired speed and direction of rotation. Pulse Width Modulation (PWM) signals are utilized for precise control of the motor's speed by varying the average voltage applied to the motor windings. Overall, the proposed system offers a versatile and

efficient solution for BLDC motor speed control, catering to various industrial, automotive, and consumer electronics applications. Its user-friendly interface, advanced control algorithms, and robust hardware components make it suitable for a wide range of use cases, ensuring reliable operation and optimal performance.

REFERENCES

- [1] Zhang, Y., Huang, J., Huang, S., Li, Y., & Cao, H. - "A Novel Speed Control Strategy of BLDC Motor Based on Improved PID Algorithm." - 2023 IEEE International Conference on Electrical and Control Engineering (ICECE) - DOI: 10.1109/ICECE51952.2023.9717266.
- [2] Liu, Z., Yang, Y., Yang, Z., Chen, Z., & Zhang, G. - "Research on Speed Control System of BLDC Motor Based on Adaptive Fuzzy PID Algorithm." - 2022 IEEE 4th International Conference on Advanced Robotics and Mechatronics .
- [3] Gupta, R., Sharma, S., & Kumar, S. - "Design and Implementation of Fuzzy PID Controller for BLDC Motor Drive." - 2022 IEEE International Conference on Electrical, Computer and Communication Technologies (ICECCT).
- [4] S. Sakunthala, R. Kiranmayi, and P. N. Mandadi, "A study on industrial motor drives: Comparison and applications of PMSM and BLDC motor drives," in Proc. Int. Conf. Energy, Commun., Data Anal. Soft Comput. (ICECDS), Aug. 2017, pp. 537–540, doi: 10.1109/ICECDS.2017.8390224
- [5] Choudhury, S., Paul, S., & Dutta, S. - "Sensorless Speed Control of BLDC Motor using Extended Kalman Filter." - 2021 International Conference on Power, Energy, Control and Transmission Systems (ICPECTS).
- [6] Luo, L., Wang, H., Liu, Y., & Wang, Y. - "Speed Control of BLDC Motor Based on Improved Adaptive PID Algorithm." - 2020 International Conference on Electrical, Communication, and Computer Engineering (ICECCE).
- [7] Maruthupandi, & P. Murugan, L. S., (2020). Realization of fault tolerant capability in a multiphase SRM drive using wavelet transform. *Microprocessors and Microsystems, 76*, 103104.
- [8] C. I. Ukpai, N. D. Nwankwo, E. C. Anene, and M. C. Anene, "Dynamic Modeling and Simulation of Brushless DC Motor With PID Speed Controller," IEEE Access, vol. 9, pp. 31110-31119, Feb. 2021.
- [9] Sebasthirani, K. & Manimegalai, M .,(2022). An optimal model for power quality improvement in smart grid using gravitational search-based proportional integral controller and node microcontroller unit. Microprocessors and Microsystems, 76, 989-1005. <https://doi.org/10.1080/15325008.2022.2143940>
- [10] J. J. Rodriguez, J. M. Espi, and G. Abad, "Direct torque control of an induction motor fed by a matrix converter," IEEE Transactions on Industry Applications, vol. 37, no. 2, pp. 367-374, Mar./Apr. 2001.
- [11] Das, S. Sengupta, and S. Bhattacharya, "Hardware-in-Loop Simulation of Fuzzy Logic Controlled BLDC Motor Drive," 2020 International Conference on Advances in Electrical, Computing, Communications and Sustainable Technologies (ICAECT), Chennai, India, 2020.
- [12] K. Sebasthirani, G. Rajesh, M. D. Bhavani, N. Varshney, T. Sathish and K. Karthigaivel, "IoT-Based Second-Life Storage System Prototype for Lifepo4 Batteries," 2023 International Conference on Advances in Computing, Communication and Applied Informatics (ACCAI), Chennai, India, 2023, pp. 1-7, doi: 10.1109/ACCAI58221.2023.10199869.
- [13] Z. Has, A. H. Muslim, and N. A. Mardiyah, "Adaptive-fuzzy-PID controller based disturbance observer for DC motor speed control," in Proceedings of the 2017 4th International Conference on Electrical Engineering, Computer Science and Informatics (EECSI), pp. 1–6, Yogyakarta, September 2017.
- [14] Maruthupandi,P,Amuthambigaiyin Sundari,Optimal Design of PID Controller for the analysis of Two TANK System Using Metaheuristic Optimization Algorithm. J. Electr. Eng. Technol. 17, 627–640 (2022). <https://doi.org/10.1007/s42835-021-00891-6>.
- [15]Zhaoxia, Xiao, et al. "Control of DC Microgrid for Electrical Vehicles (EV s) Wireless Charging." 2018 China International Conference on Electricity Distribution (CICED). IEEE, 2018.
- [16] S. A. Al-Araji, "Optimal Adaptive Backstepping Control for Speed Control of BLDC Motor Drive," IEEE Access, vol. 8, pp. 220302-220314, Nov. 2020.
- [17] Hemalatha, R., & Srinivasan, P. (2015). Speed Control of Brushless DC Motor Based on PID Controller. International Journal of Innovative Research in Electrical, Electronics, Instrumentation and Control Engineering (IJIREEICE).
- [18] Wagh, S. R., & Patil, D. R. (2013). Speed Control of BLDC Motor Using PID Controller. International Journal of Engineering Research & Technology (IJERT).
- [19] Anuradha, T., & Prasad, B. D. (2014). Design and Implementation of PID Controller for BLDC Motor Drive. International Journal of Electrical and Computer Engineering (IJECE).
- [20] Reddy, S., & Nagamani, G. (2013). Speed Control of BLDC Motor using PID Controller by Ziegler-Nichols Method. International Journal of Computer Applications, 67(13).