

Modelling and analysis of cost effective smart meter with decentralized CIS framework towards optimal network traffic

The smart meter has become necessary technology due to the high demand for energy-relevant real-time data to monitor and control the smart grids. According to UN-SDG 7. b, smart meter plays a vital role in infrastructure expansion and technological upgrades to ensure affordable and sustainable energy services in developing and underdeveloped countries. Although the smart metering approach yields many benefits, it involves complete infrastructural changes on utility providers and consumer premises. Meanwhile, the research society widely concentrates on replacing existing metering infrastructure with the new smart meter. But this changeover results in uneconomical large-scale smart meter deployments, including communications infrastructures and maintenance costs. Unfortunately, very few researches were conducted on utilizing the existing metering infrastructure to achieve the benefits of smart metering. And also, the viability of such an implementable model is less common. Aside from this, as advanced metering infrastructure emerges, smart grid communication is experiencing an increase in data traffic due to the collection of huge volumes of data. Consequently, this paper proposes a Network Enabled Smart Energy Meter that can network existing multifunctional digital energy meters without replacing them for smart meters, while reducing network traffic through a decentralized framework. The proposed design is simulated and tested in Proteus software to validate basic and decentralized data processing operations. Obtained results show that without changing metering infrastructure at consumer premises, smart metering can be incorporated using Network Enabled Smart Energy Meter with lower deployment cost for a group of houses compared with existing metering technologies. Moreover, decentralized data processing frameworks are used to reduce data traffic in smart grid communication networks, and their results are discussed in the comparative data volume analysis section. In addition, we conducted a residential consumer preference survey to validate the acceptance rate of the proposed technology for low-cost smart meter.

Keywords: Smart metering; smart meter; decentralized processing; smart grid; big data; data traffic.

1. Introduction

Handling future energy demand with a minimum carbon emission approach is a critical issue for energy sectors. Moreover, the conventional electrical grid has been degraded over time and cannot meet the ongoing power sector transition [1],[2]. In addition, the lack of real-time supervision and control makes the electrical grid unbalanced in terms of supply and demand. In order to handle the dynamic grid's nature with the minimum supply and demand gap, the electrical grid needs to be modernized into a smart grid [3]. In that process, smart Meter (SM) plays an important role since it exchanges real-time data between consumer and utility providers[4]. Though several terminologies like smart energy meter, remote meter, and intelligent meter are used among the research community, the SM is widely accepted. In the course of history, the measurement of electricity consumption had

* Corresponding author: Ezhilarasi P, Dr.M.G.R. Educational and Research Institute, Department of Electronics & Communication Engineering, Chennai, India, 600095, E-mail: ezhilarasih@gmail.com

¹Dr.M.G.R. Educational and Research Institute, Department of Electronics and Communication Engineering, Chennai- 600095, India

²Dr.M.G.R. Educational and Research Institute, Department of Electrical and Electronics Engineering, Chennai- 600095, India

³Aalborg University, The Faculty of Engineering and Science, Aalborg, Denmark

undergone numerous changes along with technological advances. Because of this, the energy meter used for calibration has continuously evolved with added features and functionalities over time. In conventional meter a reading person has to visit consumer premises to take the reading every month once, which leads to errors in reading, bribery of the reading persons, and delays in generating bills [5]. The above-said issues are removed by SM where the human workforce is not needed for meter reading and bill generation. Compared with the conventional meter, a SM can record additional fine-grained real-time information and communicate it to utility providers through communication infrastructure. Consequently, the SM offers a diverse range of intellectual benefits to consumers, utility providers and society which are illustrated in the Figure 1.

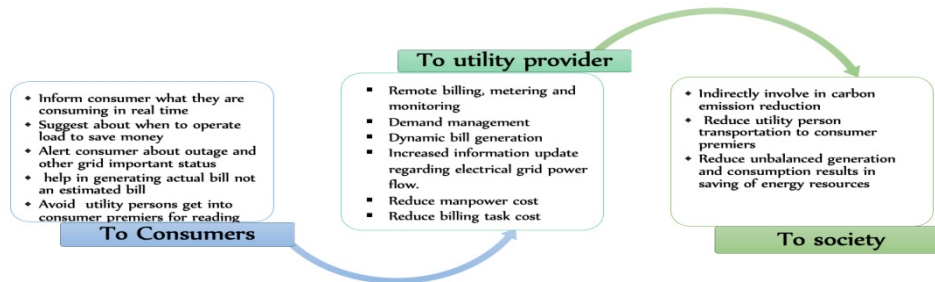

Figure. 1SM benefits to consumers, utility provider and society

Furthermore, these benefits can only be achieved if smart meters can read the following parameters in real-time current, voltage, power, reactive power, power factor, and energy consumed [6],[7]. So, the transition of energy meters from conventional to smart will make the electric grid reliable in terms of electricity generation, transmission and distribution. Furthermore, other smart sensor nodes collect grid information and send it to the utility's Head End System (HES) in order to fully automate and modernize the grid. Data collected from various sensor nodes can be processed by smart grids after collected in HES using different management systems such as Geographic Information Systems (GIS), Meter Data Management Systems (MDMS), Outage Management Systems (OMS), Customer Information Systems (CIS), and Demand Response Management Systems (DRMS) to achieve a wide range of applications [8]. As regards the above management systems, CSI focuses more on consumer benefits than utility benefits. With centralized data processing, all collected data is fed into the central server to enable the different management systems, causing data traffic in the communication network as a result of continuous data pooling. Furthermore, the CIS is heavily reliant on consumer data that is collected by the SM at the consumer's house. Recent days the SM has been receiving exceptional research attention due to its role in electrical grid modernisation. The rollout of smart meters is estimated to reach 729.1 million in 2019 and a decadal growth rate of 3013% [9].

Although, the cost for deploying smart meters at a massive level will play a critical role in determining its benefits since, the cost is directly proportional to SM functionalities [10]. Potential investment and benefits of smart meters can be quite different in various countries and circumstances. As a result, developing and underdeveloped countries face difficulties in the massive rollout of smart meters due to the lack of consumer acceptance and different economic strata within the countries. Recent studies and research on smart meters have

focused on installing a new SM in every consumer premises to enjoy the benefits of smart metering. However, this will put financial pressure on weak economic countries as well as low-income consumers results in dumb node (consumer without smart meter) in the smart grid eco system. Although the design and development of smart meters have been studied and investigated intensely, little attention is paid to utilising the existing metering infrastructure for smart metering instead of a complete revamping metering infrastructure. This paper discusses the importance of utilising existing metering infrastructure without replacing it for smart metering to focus on the lower cost deployment strategy. In addition, some of the features of CIS (such as energy consumption information and bill details) are implemented in a decentralized framework by programming Network Enabled Smart Energy Meter (NESEM) to report consumer information based on consumer queries. A consumer opinion survey is also conducted among the residential consumers to validate the NESEM design for lower deployment cost strategy.

2. Related works

Literature researches on smart meters cover a wide variety of topics like meter data analytics, communication analysis, demand or load management, smart grid management with SM data, load estimation or forecasting and peak load estimation, state estimation, SM privacy and security, SM tariff, smart grid management with SM data, etc. Noelia Uribe-Pérez et al. [11] briefly discussed the trends and status of global SM deployment. Yasin Kabalci conducted a detailed survey on smart metering methods along with communication standards [1]. Comparison of SM communication standards are discussed by Sabine Erlinghagen et al. for European countries [12]. Challenges and issues of SM are detailed in [13] by Soma ShekaraSreenadh Reddy Depuru. Lulu Wen et al. discussed the challenge and benefits of big data collected from smart meters and smart grids [14],[15]. Domenico Capriglione et al. discusses the need for decentralised metering when compared with the centralised approach [16]. Ezhilarasi et al. [17] detailed the major works done by various authors on the SM on different topics. Unfortunately, less focus is given to the cost-effective design and architecture of smart meters. SM design normally includes one microcontroller for sensing and calculating the energy details, which is communicated to the desired data center through different communication modules. Details some of the literature related to the SM in the aspects of design and architecture done by various authors are reported in Table 1.

Table 1: SM Literatures in the aspects of design architecture

Author	Microcontroller	Communication	Data routing destination	Software used
Shang-Wen Luan et al.[18]	dsPIC30F	ZigBee	Rear-end processing system	MULTISIM
Giuseppe Del Prete et al.[19]	STM32F107VCT6	CAN bus	Data aggregator	----
H. M. Zahid Iqbal et al.[20]	dpPIC30F3014	GSM	Utility Administrator and consumer (on demand)	----
Himshekhar Das et al.[21]	-----	GSM	Utility server	----
L. C. Saikia et al.[22]	Arduino	GPRS	Utility web hosting,	----

Nithin B et al. [23]	Arduino	Virtual terminal	customers mobile phone Server	proteus
V.Preethi et al.[24]	ARM7	Zigbee	base station regularly	----
R. Morello et al [25]	National Instruments Single-Board RIO 9626	Internet or electrical network	Control station	----
Fadhela K. Handhal et al.[26]	Arduino	RF Transreceiver	Remote station	
S. Elakshumi et al.[27]	Arduino	PLC	Main server	MATLAB
Shashank Singh et al[28]	Arduino	GSM/Transceiver	server	MATLAB
Teddy Surya Gunawan et al. [29]	Arduino	Ethernet	Server	MATLAB
SaikatSaha et al.[30]	Arduino	Wi-Fi	Cloud	PROTEUS
Abdul Ahad, et al.[31]	Arduino	GSM	Central server	----
QasimMalik et al.[32]	Arduino	GSM	User mobile phone	PROTEUS
Farah Sabir et al.[33]	IC ADE-7753	Wi-Fi module	Web server	----
Zohaib Sultan et al.[34]	PIC18F452	GSM	Connectivity server	----
Himanshu K. Patel et al. [35]	Arduino	GSM	System server	----
NagibMahfuz et al.[36]	Arduino Nano	GSM	Cloud server	----
G.I. Rashed et al. [37]	PIC18F452	GSM	Server	PROTEUS
M.Leelavathi et al.[38]	PIC16F877 microcontroller	GSM	Server	----

All the research mentioned earlier and the global scenario insists on a separate SM for every house premises to develop AMI. But these concepts are economically infeasible for the developing and underdeveloped countries with weak economic status. Almost all literature focuses on designing and developing a new SM for smart metering in households. And also, the designed SM always communicates the data either directly to the utility server or to the local DCU, which in turn route the data to the server. In the AMI network, houses without smart meters are considered dump nodes or blind spots. From the cost analysis report [39] of ISGF in the Indian context, all meter nodes need to be replaced with smart meters for the full benefits of AMI. According to the current scenario, the deployment cost for replacing all old digital meters to smart meters will increase the budget of SM deployment. In developed countries, people can purchase smart meters regardless of the cost. But situations in India are restricted to the SM cost. In addition, the big data (10³ of tera byte) generated by advanced metering infrastructures is one of the major concerns of smart grid technology [40]. The realization of a fully functional smart grid requires the interaction of a large number of smart nodes that gather real-time information and send it to a central server for further processing. The smart grid will collect a greater volume of data as the number of smart devices such as smart meters, AMIs, RTUs (Remote Terminal Units), Phase Measurement Units, WAMs (Wide Area Monitoring Systems), SCADAs (Supervisory Control And Data Acquisition), and IEDs (Intelligent Electronic Devices) increases substantially in the near future. Furthermore, a variety of semi-structured, quasi-structured, unstructured, and structured data are collected to enhance grid analytics. As shown in the following Table 2, the above- mentioned data varieties are described in more details.

Table 2: Characteristics of big data from smart grid

Variety of the data	Formats
Structured	Comma-Separated Values (CSV) Relational Database Management System (RDBMS) Online Analytical Processing (OLAP) Relational tables containing customer information Electrical consumption data in numbers and strings
Semi-structured	XML and JSON data files Web service data Load monitoring Power quality data
Quasi - structured	Web clickstream (contains erratic formats) and Data values Web scrapping data Search engine results
Un- structured	Census and text Social media streams Tweets Audio Video Photographs

According to [14], if the data volume increases in the network, the data congestion encountered by the AMI network is high. This data congestion results in delay and loss of granular information. In addition, [16] discuss the importance of the decentralized metering approach in smart grid for smart metering since smart grid invokes a massive transition of whole grid infrastructure at different level like design, communication and management software with huge investment cost. In a centralized framework, processing structured data, along with other structured data varieties, is tedious due to pre-processing (data integration & data cleaning) [40]. This problem can be mitigated with the decentralized data processing (structured data format only) CIS framework incorporated in NESEM. This decentralized approach reduces the amount of storage needed on the central server to store consumer data and the time required to respond to consumer queries in real time. LTE's widespread presence makes it a popular choice for smart grid communication, reducing utility providers' financial burden. Because LTE is used for other services such as communications such as video streaming, web browser, voice, chat and e-mail services [41], so a limited amount of bandwidth is allocated to SM communications. Consequently, inefficient use of limited bandwidth will increase communication network data traffic. This can be mitigated with a decentralized data processing framework enabled in NESEM. To validate the traffic reduction in the LTE communication network due to the decentralized framework, this paper analyses only billing information, customer energy consumption information, and outage/blackouts information from CIS.

To deal with the above-said problems (higher deployment cost and network data traffic), we proposed a NESEM, a common meter for a group of houses without replacing old metering infrastructure with reduced overall meter deployment cost. Data congestion of the existing smart metering concept is mitigated in this proposed metering infrastructure with the help of decentralized CIS processing. This work is one of the objectives of IGEN. PAASHAM Alliance Research Group which is affiliated under The Institution of Green Engineers (IGEN) to mitigate the research gap and enhances further research activities. The Objective of PAASHAM (High Performance Affordable Smart Meter) is aimed to design and develop next generation smart meter, which will help to achieve the targets of UN

Sustainable Development Goal 7. In line to justify the need of the research, residential consumer opinion survey conducted and its details discussed in the next section.

3. Consumer opinion survey

Current projects and studies on the SM are in the piloting stage in India. There is no active implementation of metering infrastructure model to the consumers which would play a key role in better acceptance of the smart metering concept [21]. To examine the acceptance of this proposed metering concept among residential consumers opinion survey is conducted on existing smart metering technology and NESEM at Tamil Nadu, a southern state of India. The questioners were set in simple terms that explain the overall concept of smart metering and proposed NESEM to reach commoners. A pilot survey was conducted among 10 persons to analyse the participant's understanding level on survey questioners. According to results from the pilot survey, questioners were modified, and the final survey was conducted among 3000 participants through online mode (google forms). According to Indian household electrification status, Tamil Nadu has a total of 1,02,83,678 houses with electricity [42]. Out of this count, 75% need smart metering (consumer with digital meter-77,12,758). So, for this survey, the population size is considered 77,12,758 with a confidence level of 95% and margin error of 1.9% results in a sample size of n=2660. Since the sample size is more than the received response, the survey outcomes' results are considered appropriate to represent the total population size with a confidence level of 95%. The outcomes of important questioners are discussed and illustrated in the following section. From the outcomes illustrated in Figure 2. residential building is equally shared between the single and double bedrooms compared with the bungalow. This question is included to formulate the load model for proteus simulation platform. In addition, with that 91.8% of participants are interested in reducing electricity bills by monitoring their consumption, which shows the importance of SM deployment

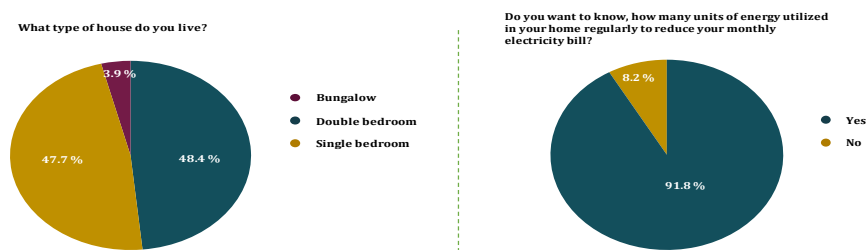

Figure. 2 Responses set I

From Figure 3., among the population size, 79.5% have the digital meter in their households, which supports the idea of converting old meters to smart meters without replacing old ones. The above results indicate the viability of using existing metering infrastructure for smart metering. And also 70.3 % of participants are interested in the national SM rollout program which shows the active participation of consumers in SM rollout.

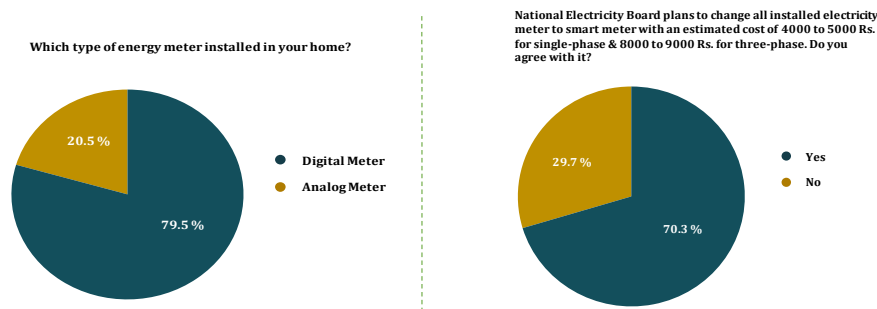

Figure3: Responses setII

From Figure 4., on explaining our proposed idea without motioning the cost compared with existing smart metering technology 31.6% of respondents are interested in NESEM. But with cost for proposed idea reduction, 73.4% respondents are agreed to our proposed idea for smart metering when compared with the counterpart and is reported in right side of Figure 4.

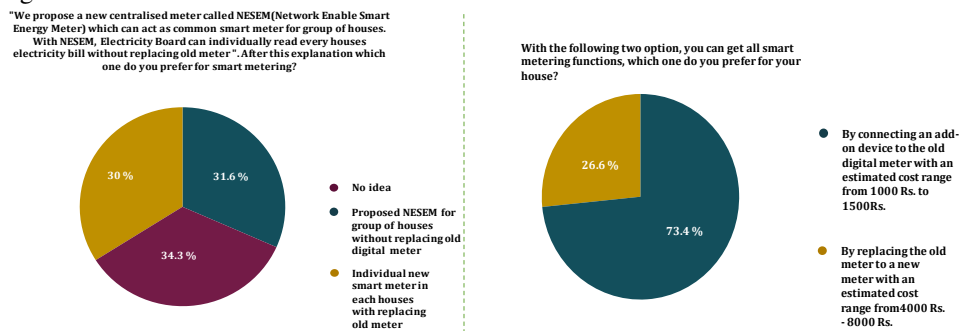

Figure 4: Responses related to the proposed NESEM design acceptance

From this residential consumer opinion survey, it is concluded that consumers are willing to accept the concept of smart metering over conventional metering. In spite of this, the cost of upgrading infrastructure to a SM makes them accept NESEM for smart metering because it is low cost.

4. NESEM

4.1. Design Methodology

Global scenario and literature research heavily focus on developing various smart-meter designs, and all are for individual households to do the advanced metering. In addition, all works on smart meters focused on centralized processing to establish smartness in the electrical grid. Consequently, a separate SM for each household results in huge deployment costs. With the existing approach, all the data collected from each SM is collected by Data Concentrator Unit (DCU) and send the utility server through wide area network communication technology. A centralized approach to processing all collected data makes the grid unestablished because of the volume of information processed in real-time. The comparative architectural network layout of the proposed NESEM and Existing SM illustrated in Figure 5. The design and development of the proposed NESEM consists of three parts 1. Designing an add-on device to extract the real-time data from the existing

digital energy meter.2. designing the central NESEM to process the extracted data for the advanced metering process. 3. Formulating decentralized smart metering and CIS algorithms. This proposed work considers a digital meter with serial communication since, according to the survey, it is estimated that 72.9% of households have digital energy meters. To mitigate the problem caused by dumb nodes in AMI, all households are equipped with one add-on device along with the digital meter. Adding a communicable add-on device replaced the original dumb node with a communicable digital meter.

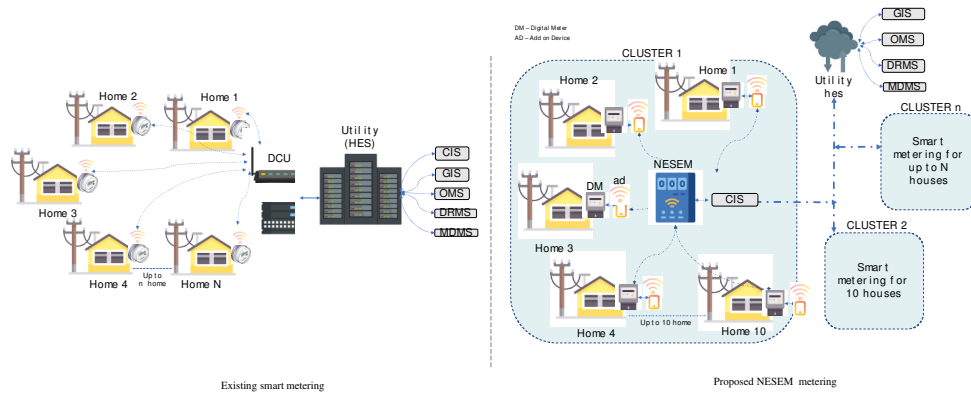

Figure 5: Comparative architectural network layout of the proposed NESEM and Existing smart metering

In accordance with the simulation and microcontroller specification, a NESEM can be used to do smart metering for up to ten households. Add-on device modelling involves two process flows, the first extracting real-time data, and the second communicating it to the central NESEM. On the other hand, NESEM is designed to collect and process data routed by various add-on devices to enable advanced metering. In Figure 6, the schematic block diagrams of the add-on device and NESEM are shown.

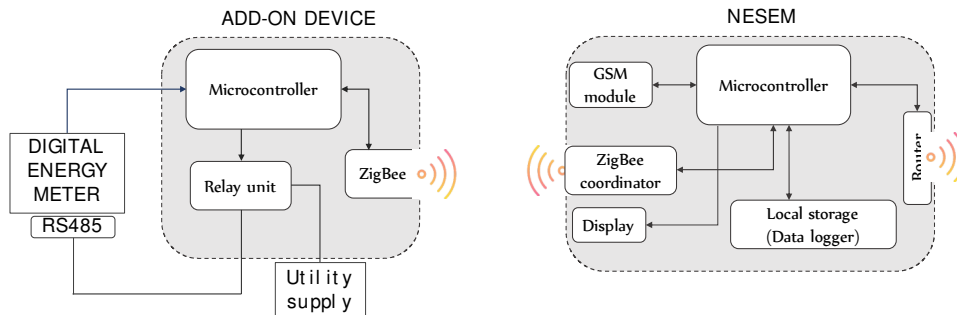

Figure 6: Block diagrams of add-on and NESEM

Clusters of consumers are created based on their distance from NESEM, each covering ten houses maximum. The NESEM network is based on a star topology, in which every add-on device from a cluster is directly connected to NESEM. The add-on device uses the RS485 serial communication port of the digital energy meter for data extraction with the help of a microcontroller. Microcontroller is programmed to control and manage the data extraction

and communication process in real-time. Data extracted in real-time are transmitted to NESEM via a wireless module (ZigBee transceiver). Since ZigBee's wireless communication module is low-power, low-cost, and offers high nodal coverage, it was selected for this study. A Zigbee communication module can be categorized into three types. 1. End devices 2. Zigbee coordinator 3. ZigBee router. Therefore, add-on devices in each household are configured to be Zigbee end devices, while the NESEM is configured to be a Zigbee coordinator. As NESEM and Zigbee operate in a master-slave configuration, each add-on device (end node) is assigned a slave ID (consumer ID), which is controlled by master NESEM. Add-on devices communicate data to the ZigBee coordinator in NESEM, which is then transferred to the microcontroller (Arduino Mega) for further processing. Instead of sending all data to the server, collected data from different households is stored in the local storage of NESEM. A display unit is also included in NESEM for visual and graphical indication of metering activity. As part of NESEM, a GSM module provides notifications and alerts to consumers, delivering messages based on their requests. SM are simulated in two case studies based on the SM benefits to the utility (remote metering and controlling such as remote metering, remote supply connect/disconnect) and benefits to the consumer (decentralized CIS such as energy consumption, billing and IHD update). A summary of the tested results is provided in the results section for each case study. In Figure 7, the flow chart outlines the different processing mechanisms for each function of the proposed NESEM.

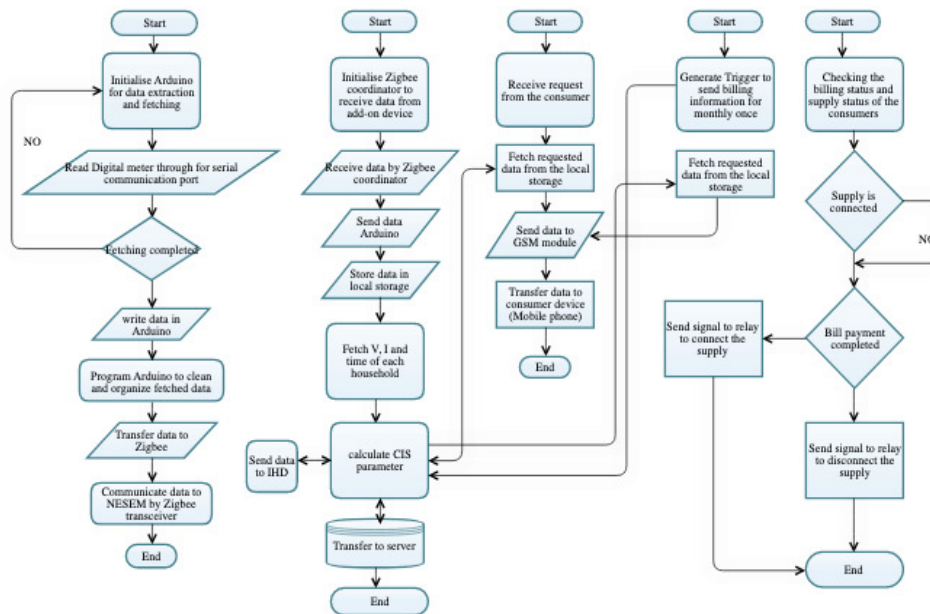

Figure. 3 Algorithms for processing mechanism of NESEM

4.2. Simulation results and discussions

Proteus 8 Professional is opted for designing and simulating the NESEM and add-on module to validate the viability of smart metering. Proteus has the virtual emulation capability of Arduino and other required tools for proposed work. Along with that Arduino IDE, open-source software used for writing codes for Arduino controllers. After execution

of the written codes in IDE, .hex file is generated and inserted into the proteus software for simulation. Virtual Serial Ports Emulator (VSPE) software is used to connect all ports of communication modules (Zigbee) internally. With this COM ports pairs were generated and assigned to respective Zigbee modules. Architecture of the proposed work consists of five different designed models, namely 1. Load model (Resistive and inductive loads), 2. Digital meter model, 3. Add-on device model, and 4. NESEM model apart from inbuilt proteus library models Zigbee modules. Test is conducted for two case studies such as case 1-Remote metering and controlling, case 2-Decentralized CIS. The simulation architectural layout of the NESEM and simulation block of add-on device is shown in Figure 8, 9 respectively.

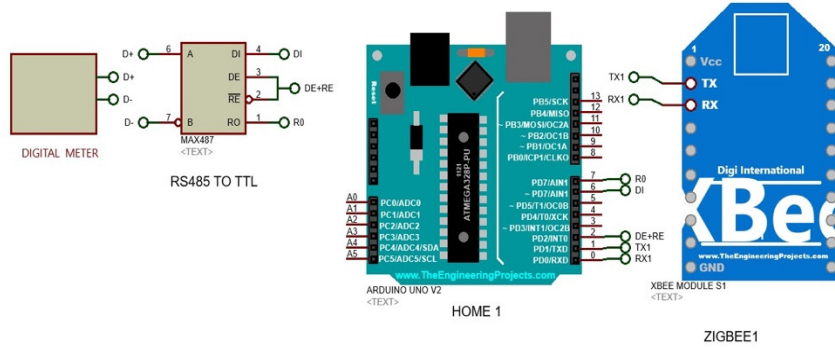

Figure 8: Simulation design model of the add-on device

The digital meter model is responsible for measuring the amount of energy consumed in the household with the reading from current and voltage sensors. Analog read functionality of Arduino the values of current and voltage are measured in the digital meter block. RS485 to TTL module used to establish the communication between the serial ports of the digital meter and the add-on device. Driver Enable (DE) and Receiver Enable (RE) pins of RS485 to TTL are connected together with pin 2 add-on device Arduino. By decaling pins 7,6 as software serial pins, the Driver Input (DI) and Receiver Output (RO) pins of RS485 to TTL can send data by connecting 7 and 6 with DI and RO. Extracted data is communicated to the NESEM through the Zigbee connected in TX0 and TX1 of add-on device Arduino.

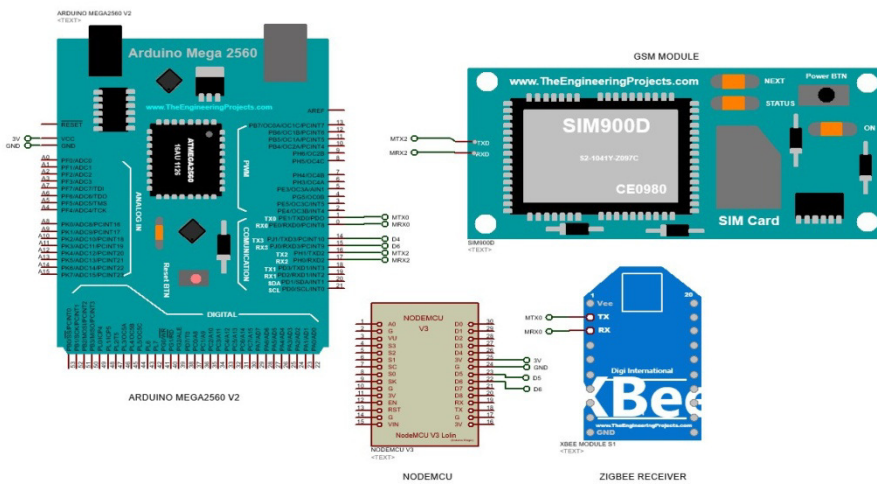

Figure 9: Internal simulation design of the proposed NESEM

NESEM model consists of the main controller (Arduino MEGA), ZigBee transceiver, GSM, and esp8266 in its architecture. Upon receiving the communicated from the Zigbee Transceiver at the add-on device Zigbee coordinator collects the information and store in the local memory of NESEM. Arduino Mega has 4 dedicated hardware serial port and in that TX0, RX0, TX3, R31 and TX2, RX2 are connected with GSM, esp8266 AND Zigbee module respectively. Because of the simulation software constraints, the different case studies mentioned earlier are simulated tested separately and are discussed in the following section. esp8266 enables server communication to receive the control signal for billing updates. GSM is programmed to send consumer consumption updates upon receiving the request command from the users.

Case 1: Utility benefits – remote metering and remote supply connect/disconnect.

The utility's smart metering process entails in two key steps: remote metering and remote supply connection and disconnect. Traditionally, household energy consumption is measured and billed by human workers. During this process, a great deal of time was required, transportation costs were incurred, and labour costs were increased, resulting in larger emissions of CO₂. Contactless monitoring and instant metering are possible with remote metering, reducing both CO₂ emissions and processing times. NESEM able to send consumption detail in real time to the server using es8266 and 12 hours energy consumption of five houses are plotted and illustrated in the following Figure 10.

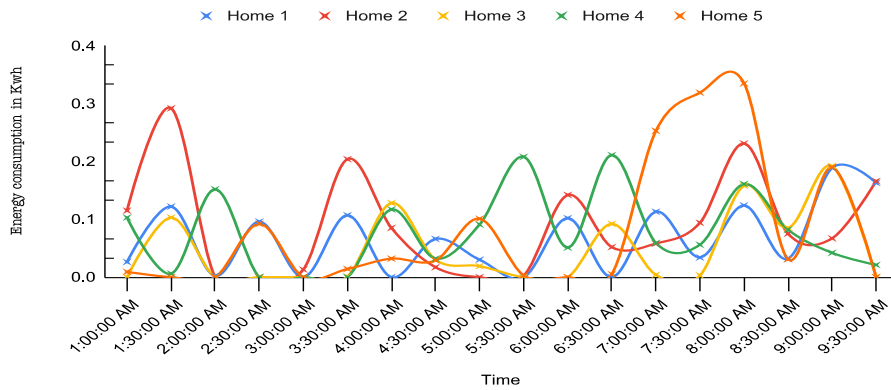

Figure 10:12 Hours energy consumption plot for five houses

With remote supply connect/disconnect features, monitoring and maintaining household payment status can be accomplished without a manual visit. NESEM is programmed to check each consumer's payment status remotely and disconnect or reconnect the household's supply without human intervention. This feature is initiated by a command signal from the utility center's data base. Virtual terminal windows are used to feed the billing status of the five houses to the NESEM in this simulation. As a result, NESEM determines whether to connect or disconnect a consumer's supply based on the local connection status. The NESEM sends a control signal to the programmable relay in the add-on device based on the decision status. The simulation result of this functionality is detailed in the following Table 3.

Table 3: Characteristics of the thermal units

Command initiated from the HES	Consumer ID	Supply connection status of ID	Billing status	Relay status	Decision status signal to relay
YES	Home 1	Connected	Paid	ON	ON
NO	Home 2	Connected	Not paid	ON	No action
YES	Home 3	Disconnected	Paid	OFF	ON
YES	Home 4	Connected	Paid	ON	ON
YES	Home 5	Connected	Not paid	ON	OFF

Case 2: Decentralized CIS – remote billing, energy consumption updates and IHD updates

Efficiency in energy utilization contributes greatly to the reduction of energy generation. In order to accomplish this, consumers need to participate in energy conservation programs, which is achieved when consumers know what they are consuming in real time. NESEM directly notifies consumers regarding real-time consumption details without requiring a central server. Due to NESEM, consumers do not have to constantly log into utility servers in order to obtain consumption details. In the NESEM, a GSM module sends the necessary data in the form of SMS messages based on the requests raised by the consumer. It is possible for consumers to access this information through their mobile phones. A major feature of the CIS is the billing, consumption, and IHD updates that help consumers conserve energy and save money. In energy consumption updates, NESEM reports the details of energy consumption based on the checking queries raised by consumers through SMS, and updates the billing information on a monthly basis based on utility regulations. Simulation results of these feature are show in the Figure 11.

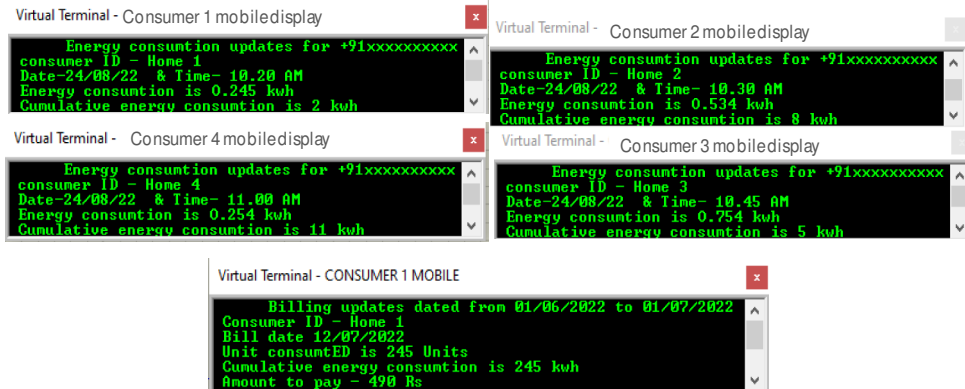

Figure 11:Remotemetering and billing

The IHD service delivers real-time consumption and grid control data to consumers in real-time to promote energy conservation. Since IHD covers most of the data transfer between utility companies and consumers, the communication network has a very high data volume. By avoiding the constant downlink of data from the utility HES, decentralized programming of the NESEM sends the real time data by itself results in reduced data traffic in the smart grid communication.

5. Data volume and traffic analysis of Decentralized NESEM frame work

Smart grid big data are categorised into different entities such as volume (amount of data in bytes), velocity (speed of data transfer), variety (type of data), veracity (messiness of the data), and value (quality of retrieved data). Additionally, bidirectional communication from the consumer end to the utility end is divided into two parts: 1. Uplink data volume, 2. Downlink data volume. Monitoring and controlling the grid depends mainly on uplink data, while monitoring and controlling consumer energy consumption depends on downlink data, as illustrated in the following Figure 12.

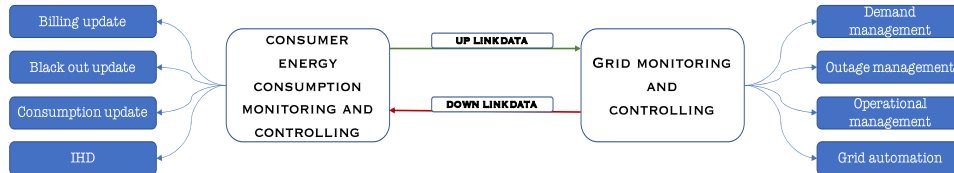

Figure 12: Benefits of uplink and downlink data

In a smart communication network, the frequency of uplinks and downlinks is determined by the requirements of both entities, and this frequency determines the volume of data transferred. Structured data plays a major role in billing, consumption, and IHD updates, and they can be obtained easily from the consumer end, so decentralized CIS frameworks can be adopted to solve big data issues associated with smart grids. As part of this study, Volume and Variety characteristics are considered in analysing uplink and downlink data [44] related to consumer monitoring and control. We formulate a mathematical model to analyse the volume of data transferred in communication medium for both uplink and downlink data. The mathematical model is examined for one year with billing, energy consumption, and IHD updates information for 1 million consumers in two scenarios 1. Existing Centralized data processing framework and 2. NESEM decentralized data processing framework. As part of the analysis, some prerequisites are referenced and assumed from the existing literature. Pocket sizes vary based on details contained in the pocket, such as meter id, total energy consumption, tamper records, and other meter information [45]. As referenced in [46] the following Table 4 summarizes the pocket size.

Table 4: Pocket size of the data from SM

Pocket information	Size of the pocket (byte)
Meter ID	7
Total energy consumption	4
Tamper Status	2
Available Credit	4
Date Stored	4

For this analysis we consider only Meter ID and total energy consumption are encapsulated in the pockets (11 bytes) which send from the smart meter. Time period and total number of consumers for this study are pre fixed values such as 10^6 and 24 months respectively.

Centralized data processing

$$U_{CDV} = n * ((f_{SM} * b_{SM}) * t) \tag{1}$$

$$D_{CDV} = n * (((f_{HES_b} * b_b) + (f_{HES_{cu}} * b_{cu}) + (f_{HES_{IHD}} * b_{IHD})) * t) \tag{2}$$

Decentralized data processing

$$U_{DDV} = m * ((f_{NESEM} * b_{NESEM}) * t) \tag{3}$$

$$D_{DDV} = n * (((f_{HES_b} * b_b) + (f_{HES_{cu}} * b_{cu}) + ((f_{HES_{IHD}} + f_{NESEM_{IHD}}) * b_{IHD})) * t) \tag{4}$$

U_{CDV} = Uplink volume of data in centralized data processing

D_{CDV} = Downlink volume of data in centralized data processing

U_{DDV} = Uplink volume of data in decentralized data processing

D_{DDV} = Downlink volume of data in decentralized data processing

b_{SM} = bytes from smart meter = 11, *b_{NESEM}* = bytes from NESEM = 32

f_{SM} = frequency of smart meter data updates,

f_{NESEM} = frequency of NESEM data updates

b_b = bytes of billing data, *b_{cu}* = bytes of consumption updates, *b_{IHD}*
= bytes of IHD updates

f_{HES_b} & *f_{NESEM_b}* = frequency of billing updates from HES & NESEM

f_{HES_{cu}}} & *f_{NESEM_{cu}}} = frequency of consumption updates from HES & NESEM*

f_{HES_{IHD}}} & *f_{NESEM_{IHD}}} = frequency of IHD updates from HES & NESEM*

Total number of consumer (*n*) = 10⁶

m = number of NESEM = 105

pocketsize = *b* in bytes

Total time = *t* = 1 year

In a centralized CIS framework, data collected from consumers is routed first to a nearby DCU, then to a central HES for processing. The uplink data volume in this scenario is restricted to SM data only, not other smart devices like PMUs and RTUs. SM updates the consumption details of 11 bytes of consumption details for every 15 minutes (b=44 bytes for 1 hour) through nearby DCUs. Thus, the frequency of pooling energy consumption details is 96 times a day and 35040 (f) times a year. For 1 million consumers, it is calculated that 385.440x10⁹ bytes of uplink data is transferred to a central server at frequency of 35040 by using equation 1. In case of downlink, the total volume of data transferred is the cumulative of billing data, energy consumption update, IHD updates. Billing information is updated to the consumers for every once a month or twice a month depending upon the utility policy. In this paper, the monthly billing method is considered for the analysis, so the information flow occurs once every month (*f_{HES_b}*=12). The size of a standard SMS is 140 bytes (*b_b*=140). For 1 million consumers, one year will result in 1.68x10⁹ bytes of billing data (downlink data). As for IHD downlink volume, it is calculated assuming that from the central server to IHD, 80 bytes (*b_{IHD}*) of information is transferred on average. According to [42] a single consumer checks with IHD on average five times a day (*f_{HES_{IHD}}}* = 1825) for updates. A total of 146x10⁹ bytes of downlink IHD data is transferred each year from the utility HES to the 1 million consumers. Based on the consumer request (*f_{HES_{cu}}}*=1825, similar to the frequency of IHD checking), the downlink data volume for one year with packet size of 140 bytes (*b_{cu}}*) is 255.5x10⁹ bytes is derived by equation 2. Over a period of 24 months, 385.440 x 10⁹ bytes of uplink data and 403.18 x 10⁹ bytes of downlink data are transferred between SM and HES for 1 million consumers.

Unlike centralized frame work the Decentralized CIS frame work with NESEM, data routing mechanism involves mainly communication between add-on device and NESEM in order to implement the CIS. In this scenario, the HES receives only the uplink data, while all downlink data is downloaded from the NESEM with decentralized CIS programming.

Furthermore, according to the NESEM design, 1 lakh NESEMs will cover one million consumers (simulation aspect). From the simulation it is assumed that NESEM updates 20 bytes (b_{NESEM}) of 10 consumer information for every 15 minutes ($f_{NESEM} = 35040$ for one year). For 1 lakh NESEM the uplink data volume is calculated for $m=105$ (NESEM count) is resulting in 70.08×10^9 bytes for one million consumers associated with a 1 lakh NESEM for one year using equation 3. However, the downlink traffic originates from NESEM for billing and energy consumption updates. From NESEM 1.68×10^9 bytes of information are used for consumer billing every month ($f_{NESEM_b} = 12, b_b = 140$) for the period of 1 year. In contrast to centralized processing, in this case the downlink traffic is created by NESEM, not by HES. Energy consumption updates via SMS are also generated by NESEM with ($f_{NESEM_{en}} = 1825$) for one year, similar to IHD checks) downlink data volume of 255.5×10^9 bytes for one year and packet size of 140 bytes (b_{CU}). Unlike in centralized data processing in decentralized case grid control data of 20 bytes is transferred from the HES and the remaining 60 bytes are generated from NESEM to IHD. As a result, during a one-year period with display checking frequency of five times a day ($f_{NESEM_{IHD}} = 1825$), the downlink volume of 3.65×10^9 bytes is delivered from HES to 1 lakh NESEM and 109.5×10^9 bytes generated from one lakh NESEM to consumer end. So as total of 113.15×10^9 bytes of IHD data transferred from HES to 1 million consumers. In conclusion, 70.08×10^9 bytes of uplink data were transferred from consumer to HES, 3.65×10^9 bytes were transferred from HES to NESEM, and 370.18×10^9 bytes of downlink data were transferred from 1 lakh NESEM to consumer end (for 1 million consumers) and is calculated using equation 4. These details are illustrated in the following Figure 13 and Table 5.

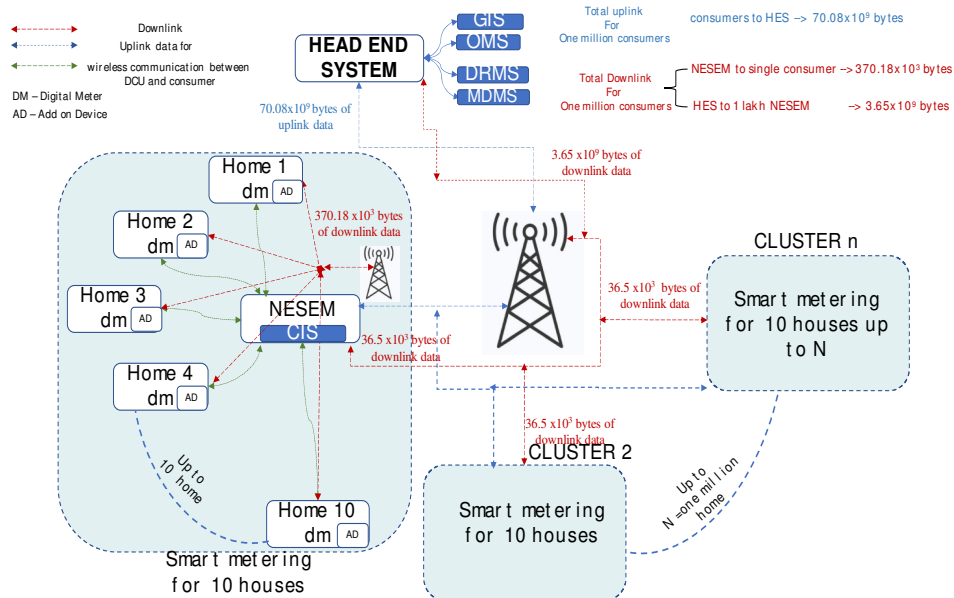

Figure 13: Decentralized framework uplink and downlink

Table 5: Data volume in centralized and decentralized CIS framework

Data volume	Centralized CIS	Decentralized CIS
Uplink	Consumer to HES	Consumer to HES
	385.440×10^9 bytes	70.08×10^9 bytes
Downlink	HES to 1 million consumers	HES to 1 lakh NESEM
	403.18×10^9 bytes	3.65×10^9 bytes
		NESEM to 1 million consumers
		370.18×10^9 bytes

Functionality of SM is not restricted to certain limits and varies from meter to meter based upon vendor, consumer, and utility preference. All smart meter’s support remote metering, monitoring, controlling, consumer alert notifications, and remote disconnecting. We simulate and test all such functionalities in this paper. In comparison with existing smart metering concepts, NESEM has a smaller uplink and downlink data volume due to its decentralized CIS framework. Due to this decentralized metering process, a powerful HES is not required to store large volumes of big data collected from different meters. Consumers in developing and underdeveloped countries have difficulty switching to smart meters because they are expensive. In contrast to existing smart metering technologies, NESEM networked a group of homes without replacing the digital meters. As a result, deployment costs in the smart grid are reduced on a major scale and dumb nodes are reduced. In addition to mitigating the need to replace old meters with new ones, the NESEM enhances consumer participation in the AMI network and reduces network traffic due to a decentralized CIS configuration. In comparison to existing SM and smart metering processes, NESEM has several benefits for consumers and utilities. And also, the target 7.b of UN- SDG 7 affordable and clean energy can be realized by NESEM for developing and under developed countries. NESEM and existing SM are compared in Table 6 for their benefits and features.

Table 6: Comparative benefits and feature of existing SM and NESEM

Existing SM and metering process	NESEM and metering process
Huge deployment cost	Less deployment cost when compared with existing smart meter
Maintenance cost is high since all houses have smart meter	Maintenance cost is less a common NESEM is present for group of houses
Replacement of old meter	Replacement of old meter is not needed
Network congestion is high due to high volume data to be processed.	Network congestion is less due to minimal amount of data processed
Centralized CIS framework	Decentralized CIS framework
Dump node is more because of inactive consumer participation	Dump node is less because of networking of digital energy meter

6. Conclusion

The NESEM design simulated and its data volume of decentralized CIS framework is calculated which shows that reduced network congestion for smart grid communication with the lower-cost deployment of SM. Through the results and outcomes of the simulation, it is concluded that smart metering is viable and implementable through the proposed model of NESEM without replacing existing metering infrastructure. In addition, the uplink and downlink volume analysis of decentralized CIS indicate that traffic produced by the big data in smart grid communications is reduced. The existing SM common functionalities like remote metering, remote supply connect/disconnect, remote billing along with decentralized CIS are incorporated in the NESEM. The justification of the proposed idea among public is validated with the residential consumer opinion survey. With these obtained results and outcomes, it is concluded that the proposed model is suitable to mitigate the certain problems associated with the existing SM related to UN-SDG 7. b. The future scope of this work is expanded in terms NESEM will be added with decentralized processing MDMS to increase the benefits of it to consumers, utility, and society.

References

- [1] Y. Kabalci, "A survey on smart metering and smart grid communication," *Renew. Sustain. Energy Rev.*, vol. 57, pp. 302–318, May 2016.
- [2] H. K. M. Y. Amal A.Hassan, Faten H. Fahmy, Abd El-Shafy A. Nafeh, "Control of Three-Phase Inverters for Smart Grid Integration of Photovoltaic Systems," *J. Electr. Syst.* 6(11), 951–952., vol. 1, pp. 5–48, 2019.
- [3] J. Alfonsopalacios, A. Aguado José, J. Leiva, A. Palacios, and J. A. Aguado, "Smart metering trends, implications and necessities: A policy review," *Renew. Sustain. Energy Rev.*, vol. 55, pp. 227–233, Mar. 2016.
- [4] D. Kumar and A. H. Khan, "Roll-Out Strategy for Smooth Transition of Traditional Meters to Smart Meters," in *Lecture Notes in Electrical Engineering*, vol. 764, D. S. Pillai R.K. Dixit A., Ed. Springer Science and Business Media Deutschland GmbH, 2022, pp. 287–294.
- [5] W. Aslam, M. Soban, F. Akhtar, and N. A. Zaffar, "Smart meters for industrial energy conservation and efficiency optimization in Pakistan: Scope, technology and applications," *Renew. Sustain. Energy Rev.*, vol. 44, pp. 933–943, Apr. 2015.
- [6] K. Sharma and L. Mohan Saini, "Performance analysis of smart metering for smart grid: An overview," *Renew. Sustain. Energy Rev.*, vol. 49, pp. 720–735, Sep. 2015.
- [7] S. M. M. T. R. RoofegariNejad, S. M. Hakimi, "A Novel Demand Response Method for Smart Microgrids Related to the Uncertainties of Renewable Energy Resources and Energy Price," *J. Electr. Syst.*, vol. 2, pp. 419–441, 2016.
- [8] H. Daki, A. El Hannani, A. Aqqal, A. Haidine, and A. Dahbi, "Big Data management in smart grid: concepts, requirements and implementation," *J. Big Data*, vol. 4, no. 1, pp. 1–19, 2017.
- [9] B. K. Sovacool, A. Hook, S. Sareen, and F. W. Geels, "Global sustainability, innovation and governance dynamics of national smart electricity meter transitions," *Glob. Environ. Chang.*, vol. 68, p. 102272, 2021.
- [10] M. Malloni and J. Paris, "Understanding the total cost of smart meter operations," 2014.
- [11] N. Uribe-Pérez, L. Hernández, D. de la Vega, and I. Angulo, "State of the Art and Trends Review of Smart Metering in Electricity Grids," *Appl. Sci.*, vol. 6, no. 3, p. 68, Feb. 2016.
- [12] S. Erlinghagen, B. Lichtensteiger, and J. Markard, "Smart meter communication standards in Europe - a comparison," *Renew. Sustain. ENERGY Rev.*, vol. 43, pp. 1249–1262, Mar. 2015.
- [13] S. S. S. R. Depuru, L. Wang, and V. Devabhaktuni, "Electricity theft: Overview, issues, prevention and a smart meter based approach to control theft," *Energy Policy*, vol. 39, no. 2, pp. 1007–1015, Feb. 2011.
- [14] L. Wen, K. Zhou, S. Yang, and L. Li, "Compression of smart meter big data: A survey," *Renew. Sustain. ENERGY Rev.*, vol. 91, pp. 59–69, Aug. 2018.
- [15] A. Kumari and S. Tanwar, "A secure data analytics scheme for multimedia communication in a decentralized smart grid," *Multimed. Tools Appl.*, vol. 81, no. 24, pp. 34797–34822, Oct. 2022.
- [16] D. Capriglione, L. Ferrigno, V. Paciello, A. Pietrosanto, and A. Vaccaro, "Experimental characterization of consensus protocol for decentralized smart grid metering," *Measurement*, vol. 77, pp. 292–306, Jan. 2016.
- [17] P. Ezhilarasi, and L. Ramesh, "Review on Smart Energy Meter for low cost design," in *2019 5th International Conference On Computing, Communication, Control And Automation (ICCUBEA)*, 2019, pp. 1–8.
- [18] S.-W. Luan, J.-H. Teng, S.-Y. Chan, and L.-C. Hwang, "Development of a smart power meter for AMI based on ZigBee communication," in *2009 International Conference on Power Electronics and Drive Systems (PEDS)*, 2009, pp. 661–665.
- [19] G. Del Prete, C. Landi, S. Università, G. Del Prete, C. Landi, G. Del Prete, and C. Landi, "Real-time smart meter with embedded web server capability," *2012 IEEE Int. Instrum. Meas. Technol. Conf. Proc.*, pp. 682–687, May 2012.
- [20] Z. I. Rana, M. Waseem, T. Mahmood, H. M. Z. Iqbal, M. Waseem, and T. Mahmood, "Automatic Energy Meter Reading using Smart Energy Meter," in *Proc. Int. Conf. Engineering & Emerging Technologies*, 2014, pp. 1–5.
- [21] H. Das and L. C. Saikia, "GSM enabled smart energy meter and automation of home appliances," in *2015 International Conference on Energy, Power and Environment: Towards Sustainable Growth (ICEPE)*, 2015, pp. 1–5.
- [22] L. C. Saikia, H. Das, N. B. Dev Choudhury, and T. Malakar, "GPRS enabled smart energy meter with in-home display and application of time of use pricing," in *2016 IEEE Annual India Conference (INDICON)*, 2016, pp. 1–5.
- [23] B. Nithin, S. Bhaskaran, and S. Ullas, "Advanced Metering Infrastructure (AMI) with combination of Peak Load Management System (PLMS) and Theft protection," 2016.
- [24] V. Preethi and G. Harish, "Design and implementation of smart energy meter," in *2016 International Conference on Inventive Computation Technologies (ICICT)*, 2016, vol. 1, pp. 1–5.
- [25] R. Morello, C. De Capua, G. Fulco, and S. C. Mukhopadhyay, "A Smart Power Meter to Monitor Energy Flow in Smart Grids: The Role of Advanced Sensing and IoT in the Electric Grid of the Future," *IEEE Sens. J.*, vol. 17, no. 23, pp. 7828–7837, Dec. 2017.

- [26] C. Paper and F. K. Handhal, "Design and building a single-phase smart energy meter using Arduino and RF communication system Design and building a single-phase smart energy meter using Arduino and RF communication system," 3rd Int. Sci. Conf., no. March, 2018.
- [27] S. Elakshumi and A. Ponraj, "A server based load analysis of smart meter systems," in 2017 International Conference on Nextgen Electronic Technologies: Silicon to Software (ICNETS2), 2017, pp. 141–144.
- [28] S. Singh and M. P. Selvan, "A Smart Energy Meter Enabling Self-Demand Response of Consumers in Smart Cities of Tamil Nadu," in 2019 IEEE International Conference on Smart Cities Model (ICSCM), 2019, pp. 1–6.
- [29] F. Teddy, S. Gunawan, M. H. Anuar, M. Kartiwi, and Z. Janin, "Development of Power Factor Meter using Arduino," 2018 IEEE 5th Int. Conf. Smart Instrumentation, Meas. Appl., no. November, pp. 1–4, 2018.
- [30] S. Saha, S. Mondal, A. Saha, and P. Purkait, "Design and Implementation of IoT Based Smart Energy Meter," in 2018 IEEE Applied Signal Processing Conference (ASPCON), 2018, pp. 19–23.
- [31] A. Ahad, S. Mitra, O. Morshed, I. Khan, R. Sarker, and S. S. Chowdhury, "Implementation and Feasibility Analysis of GSM Based Smart Energy Meter for Digitalized Power Consumption with Advanced Features," in 2018 International Seminar on Intelligent Technology and Its Applications (ISITIA), 2018, pp. 403–407.
- [32] Q. Malik, A. Zia, R. Ahmad, M. A. Butt, and Z. Ahmad Javed, "Design and Operation of Smart Energy Meter for Effective Energy Utilization in Smart Cities," in 2019 IEEE Conference on Sustainable Utilization and Development in Engineering and Technologies (CSUDET), 2019, pp. 219–223.
- [33] F. Sabir, M. A. Chohan, and B. Pirzada, "Design and implementation of smart metering device using specialized IC ADE-7753 and its integration with web server for smart grid," in 2019 Second International Conference on Latest trends in Electrical Engineering and Computing Technologies (INTELLECT), 2019, pp. 1–5.
- [34] Z. Sultan, Y. Jiang, A. Malik, and S. F. Ahmed, "GSM based smart wireless controlled digital energy meter," in 2019 IEEE 6th International Conference on Engineering Technologies and Applied Sciences (ICETAS), 2019, pp. 1–6.
- [35] H. K. Patel, T. Mody, and A. Goyal, "Arduino Based Smart Energy Meter using GSM," in 2019 4th International Conference on Internet of Things: Smart Innovation and Usages (IoT-SIU), 2019, pp. 1–6.
- [36] N. Mahfuz, M. Nigar, and N. Ulfat, "Smart Energy Meter and Digital Billing System for Bangladesh," in 2020 11th International Conference on Computing, Communication and Networking Technologies (ICCCNT), 2020, pp. 1–4.
- [37] G. I. Rashed, H. Haider, and M. B. Shafik, "Improving the reliability of energy supply utilizing smart energy meter system based on GSM: case study in Pakistan," in 2020 5th Asia Conference on Power and Electrical Engineering (ACPEE), 2020, pp. 1080–1084.
- [38] M. Leelavati and K. Aswini, "Smart Energy Meter with Reading Indication using GSM," IRJET, vol. 2, 2015.
- [39] R. K. Pillai, R. Bhatnagar, and H. Thukral, "AMI rollout strategy and cost-benefit analysis for India," in 2016 First International Conference on Sustainable Green Buildings and Communities (SGBC), 2016, pp. 1–6.
- [40] B. P. Bhattarai, S. Paudyal, Y. Luo, M. Mohanpurkar, K. Cheung, R. Tonkoski, R. Hovsopian, K. S. Myers, R. Zhang, P. Zhao, M. Manic, S. Zhang, and X. Zhang, "Big data analytics in smart grids: State-of-the-art, challenges, opportunities, and future directions," IET Smart Grid, vol. 2, no. 2, pp. 141–154, 2019.
- [41] C. Karupongsiri, M. Farhad Hossain, K. S. Munasinghe, and A. Jamalipour, "A novel scheduling technique for Smart Grid data on LTE networks," 2013, 7th Int. Conf. Signal Process. Commun. Syst. ICSPCS 2013 - Proc., no. Dp 1096276, pp. 1–5, 2013.
- [42] Ministry of Power, "Household Electricity status." [Online]. Available: <https://saubhagya.gov.in/>.
- [43] D. M. Jaiswal and M. P. Thakre, "Modeling & designing of smart energy meter for smart grid applications," Glob. Transitions Proc., vol. 3, no. 1, pp. 311–316, Jun. 2022.
- [44] Y. Zhang, T. Huang, and E. F. Bompard, "Big data analytics in smart grids: a review," Energy Informatics, vol. 1, no. 1, pp. 1–24, 2018.
- [45] K. G. Ngandu, K. Ouahada, and S. Rimer, "Smart meter data collection using public taxis," Sensors (Switzerland), vol. 18, no. 7, 2018.
- [46] [46] M. Aiello and G. A. Pagani, "The smart grid's data generating potentials," 2014 Fed. Conf. Comput. Sci. Inf. Syst. FedCSIS 2014, vol. 2, pp. 9–16, 2014.
- [47] P. Xu, J. Shen, X. Zhang, X. Zhao, and Y. Qian, "Case Study of Smart Meter and In-home Display for Residential Behavior Change in Shanghai, China," Energy Procedia, vol. 75, no. August, pp. 2694–2699, 2015.

© 2022. This work is published under
<https://creativecommons.org/licenses/by/4.0/legalcode>(the“License”).
Notwithstanding the ProQuest Terms and Conditions, you may use this
content in accordance with the terms of the License.