

¹Prabhakar Holambe²Sanjay Dambhare

Comparative Analysis of SMC and INC MPPT Algorithm for Dual Input Single Output System

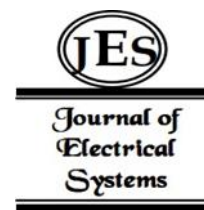

Abstract: - Many MPPT algorithms present to date have maximum output power from solar PV. This paper compares the SMC and INC algorithm results for the double input single output (DISO) system simulated on MATLAB/Simulink and verified with hardware. As the system is DISO, power is fed to the load, one from solar PV and another from the battery, with the help of a boost converter and bidirectional chopper. A control technique is designed to have constant voltage across the load and extract maximum power from solar PV under variable irradiance. In this project, the PI controller is used on the battery side, which helps to decide whether the battery works in undercharging or discharging mode. Different modes of operation are also shown in the paper, and the MPPT algorithm is used to extract maximum power from solar PV.

Keywords: Solar Photo Voltaic (SPV), MPPT, INC, SMC

I. INTRODUCTION

Nowadays, we get energy from different sources: Solar PV, fuel cells, wind energy, etc. Increasing consumption of energy resources increases environmental hazards and decreases non-renewable energy sources. There is an increase in attraction of renewable energy sources, but producing energy from them is difficult because of their fluctuating nature [3]. This renewable energy is integrated with a power system to satisfy the demand of the load. Multiple sources can be connected with the help of dc-dc to converter to fulfill the load condition. Multiple input systems are gaining popularity because of their application and reliability. In the modern power system, the demand fluctuates and has to change. So, providing a system that helps to get balance between the input sources and the output load [1],[2]. As changes in input power sources, demand of the load change, or both change simultaneously, there should be more innovative ways to deal with such conditions. Multiple input sources help to combine different voltage levels, feeding the power to the load and increasing reliability and efficiency [1]. The advantage of multiple input systems is that whenever there is a shortage of the main power supply, the auxiliary power supply comes into the picture, which improves the system dynamics [4]. Among all the renewable energy sources, photovoltaic (PV) energy is gaining more attraction, increasing at a rate of around 30 % per year. As a PV source is nonlinear and fluctuating, there is a need for maximum power point tracking (MPPT). PV panel has nonlinear characteristics, as shown in Figure 1.3. For the best utilization of these power, we are using MPPT algorithms such as particle swarm optimization (PSO), differential evolution (DE), artificial neural network (ANN), ant colony optimization (ACO), artificial bee colony (ABC), grey wolf (GW), fireflies (FF), and cuckoo search (CS). However, this method is difficult because of its complexity, implementation cost, slow tracking, and computation burden. However, conventional techniques such as perturb and observation, hill climbing, and incremental conductance have improved [5],[6]. A comparison of these MPPTs is shown in Figure 1.2.

Nowadays, multi-input converters (MIC) are becoming more popular in various medical energy power systems fields and many more. MIC plays a very important role in distributed energy resources (DERs). Using MIC provides various advantages such as reliability, cost, and less dependence on the individual converters.[11] This system consists of one unidirectional converter and on bidirectional converter. This proposed converter consists of two inputs: the battery and solar PV. The main purpose of this converter is to provide flexibility, such as during daytime when solar power is in excess, then the excess power is supplied to the battery, and during night time, the load power is supplied by the battery. The output of the solar PV is fed to the boost converter. The boost converter ensures that it maintains the voltage profile and current at the point so that its output gets maximum power. The duty cycle of the boost converter varies according to the MPPT tracking. Using the boost converter, we can step up the voltage [9].

Solar PV traps the photons that are produced due to incident solar radiation to generate electricity. Solar cells are connected in series and parallel combinations to increase the system voltage. The output of solar PV is affected by different parameters such as temperature, irradiance, short circuit current, current at the maximum power point, open circuit voltage, voltage at the maximum power point, and fill factor. Among all the parameters, temperature and irradiance are variable, so the output of the solar PV is variable throughout the day [8].

Various advancements have been made in the MPPT algorithm that are more reliable and efficient. Traditional MPPT algorithms are less efficient and less sensitive to partial shading conditions. However, some double MPP trackers have higher efficiency and good sensitivity to partial shading conditions. Using double MPP tracker method, several features can be helpful in a certain way, such as it is possible to connect different arrays in parallel having different size, having different characteristics [11].

¹ *Corresponding author: Mr. P.R. Holambe, COEP Technological University, Research scholar, Maharashtra, India, E-mail: hpr18.elec@coeptech.ac.in

² Department of EEE, COEP Technological University, Pune, E-mail: ssd.elec@coeptech.ac.in

Copyright © JES 2024 on-line: journal.esrgroups.org

In recent years, Sliding Mode Control (SMC) has emerged as a promising alternative for MPPT in PV systems. SMC is a robust nonlinear control technique capable of handling system uncertainties and nonlinearities without requiring precise mathematical models. Unlike conventional methods, SMC drives the system toward a predefined sliding surface in the state space, ensuring stable operation and rapid convergence to the Maximum Power Point (MPP).

Several recent studies have highlighted the advantages of SMC over conventional MPPT algorithms. Demonstrated SMC's superior tracking performance and robustness under varying environmental conditions []. Furthermore, [] emphasized SMC's fast response time and high tracking accuracy, contributing to enhanced energy harvesting efficiency.

In this research paper, we aim to investigate and validate the advantages of Sliding Mode Control over traditional MPPT algorithms in PV systems for Dual input Single output Systems. By leveraging recent advancements in SMC theory and practical implementations, our study seeks to provide insights into optimizing the performance and reliability of solar photovoltaic installations in real-world applications.

The inherent nonlinear behavior of DC-DC converters and PV modules often poses challenges for conventional linear controllers, resulting in suboptimal performance. Sliding Mode Control (SMC) is a promising solution in such scenarios. Unlike linear controllers, SMC does not necessitate a linearized model, making it well-suited for handling the nonlinearities inherent in these systems. SMC operates by driving the system towards a designated surface in the state space, known as the sliding surface. This surface serves as a dynamic equilibrium point, enabling the system to maintain stability and robustness even in the presence of uncertainties and disturbances. By continuously adjusting control inputs, SMC ensures that the system trajectory remains close to the sliding surface, achieving desired performance characteristics. SMC offers several advantages in PV applications, where system dynamics can vary significantly due to changing environmental conditions. Its ability to operate without relying on precise mathematical models makes it particularly appealing for real-world scenarios where system parameters may not be accurately known or exhibit variations over time. Furthermore, SMC's robustness to disturbances and its inherent ability to handle nonlinearities make it an effective choice for optimizing the performance of PV systems. By dynamically adapting to changing operating conditions and maintaining the system near the sliding surface, SMC facilitates efficient energy conversion and maximizes power extraction from the PV modules.

In summary, Sliding Mode Control presents a promising approach for enhancing the performance of PV systems by effectively addressing their nonlinear characteristics. Its robustness, adaptability, and ability to operate without linearized models make it a valuable tool for optimizing energy conversion and ensuring reliable operation in various environmental conditions.

II. BASIC BLOCK DIAGRAM

The different modes of operation are explained with the help of a circuit diagram. The proposed circuit topology consists of a multi-input DC-DC boost converter and bidirectional converter, as shown in the figure.

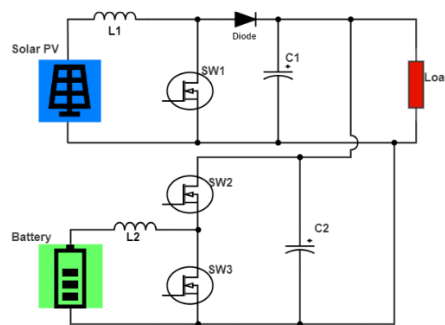

Figure 2.1: -overall circuit diagram

Where L1 and L2 are inductors, C1 and C2 are the capacitors. As the figure above shows, the upper circuit is the boost converter, and the lower circuit is a bidirectional chopper. Solar PV gives input to the boost converter. The voltage level of solar PV is less, so a boost converter is used to level up the voltage level. There is one constant voltage source, a battery, and the other, a variable current source, Solar PV. Solar PV has variable characteristics. The input of solar PV variables is temperature and irradiance. At different irradiance, the output power will differ, so to attain the maximum power, MPPT techniques are used. Variation in output power depends not only on temperature and irradiance but also on sedimentation of dust particles on the surface of the solar PV, connection of solar PV, and panel characteristics differ from panel to panel. These are the reasons the output of solar PV is not constant. MPPT techniques are used to attain maximum power at any irradiation. MPPT techniques ensure that output power is at different irradiances. There are various MPPT techniques. Every MPPT technique is unique in its own way. But all ensure that output power is maintained

to maximum in varying input conditions. Most MPPT techniques use solar PV output voltage (V_{pv}) and current (I_{pv}). The output of MPPT algorithms is the duty cycle fed to the switch.

As shown in the figure Below, the circuit is a bidirectional chopper. A bidirectional chopper is a two-quadrant chopper. This circuit comes into working condition when solar PV is insufficient to supply the load power or there is an excess of power from solar PV. Switching of the bidirectional chopper is controlled so that power can flow in either direction. Whenever excess power is extracted from the solar PV, the excess power is fed to the battery, and whenever there is an insufficient amount of power, the remaining power is getting from the battery. The switching signal for the bidirectional chopper is generated by a closed-loop system using the PI controller.

A. Capacitor and Inductor Calculations

The design of the capacitor and inductor is done by studying the voltage and current waveform across it. The circuit has a boost converter, and a bidirectional chopper is used. Overall, there are two inductors and a single capacitor. Values of the capacitor and inductor are selected so that load voltage and current are always in continuous conduction mode (CCM).

The output of solar PV is fed to the boost converter, as shown in the figure. As the name suggests, a boost converter helps boost the input voltage to a desirable value by controlling the duty cycle of the switch. There is a total of two stages in the boost converter: ON and OFF stages. When the switch is ON, current results in the energizing of inductor current flows through the switch. When the switch is OFF, the inductor changes its voltage polarity and preserves the current in the same direction.

The step-up or boost converter converts a low input supply voltage into a stabilized high output voltage. The most straightforward circuit diagram with the primary current and voltage waveforms is shown in Fig. 3.2. With switch (S1) closed, current flows through the inductor (L1) increase linearly at a ratio of $V_{IN} / L1$. During this period, the load (RL) current comes from the stored energy in a capacitor (C1). When the switch (S1) opens again, the inductor's stored energy causes high output voltage superimposed onto the input supply voltage. The current flows via the freewheeling diode (D1) to supply the output load (RL) for the charging of the capacitor (C1) again. The current flowing through the inductor (L1) dropped linearly and proportionally to

$$(V_{OUT} - V_{IN})/L1.$$

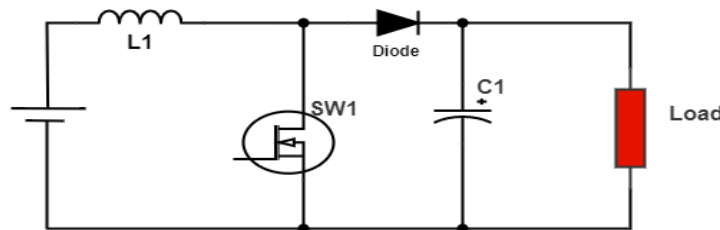

Figure 2.2: - boost converter where, V_{out} = Output voltage,

The boost converter's duty cycle is controlled by the MPPT algorithm, ensuring maximum power is extracted from the PV. The formula of the output voltage is given by Equation 1

$$V_{out} = \frac{V_{in}}{1 - D} \tag{1}$$

D = Duty cycle, $D = T_{on} / T$, $T = T_{on} + T_{off}$.

Values of the inductor and capacitor are designed such that the inductor current is always in continuous conduction mode. The formula for designing an inductor is given by: -

$$L > \frac{D V_{in}}{f \Delta I_L} \tag{2}$$

V_{in} = Input voltage,

Were

f = Switching frequency,

ΔI_L = Ripple current,

Similarly, for ripple-free output, the voltage value of the output capacitor must also be greater than the critical value. The formula for designing the capacitor is given by [11]: -

$$C > \frac{DV_{out}}{fR\Delta V_c} \tag{3}$$

Where ΔV_c =ripple voltage across capacitor

R = load resistance

Voltage and current waveform across the inductor are shown in Figure 2.3. The inductor opposes the sudden change in current across it, which is why the current waveform across it is triangular.

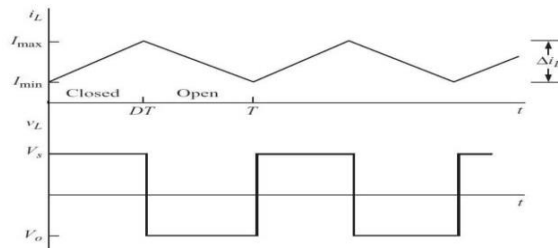

Figure 2.3: - Inductor voltage and current waveform of boost converter

A bidirectional DC to DC converter is in between the load and the battery. It forms the interface between the load and the battery system converter. The electrical circuit diagram is shown in Figure 2.4. It consists of two MOSFETs, which get complimentary control signals. Bidirectional chopper operates in two modes: -

Buck mode: - In this mode, the battery is charging. Excess power from solar PV is supplied to load and the battery. When the upper switch SW1 operates, the converter acts as a buck converter. The direction of the current forming the switch from the inductor to the battery.

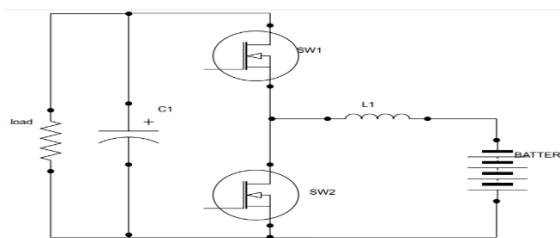

Figure 2.4: - bidirectional chopper

Boost mode: - In this mode, the battery is in discharging mode. When the lower switch SW2 operates, the converter acts as a boost converter. The direction of current is from the battery to the load.

The control signal is given to the bidirectional converter through the double loop PID; the inner loop is current, and the outer loop is voltage. The PID control signal is shown in Figure 2.5.

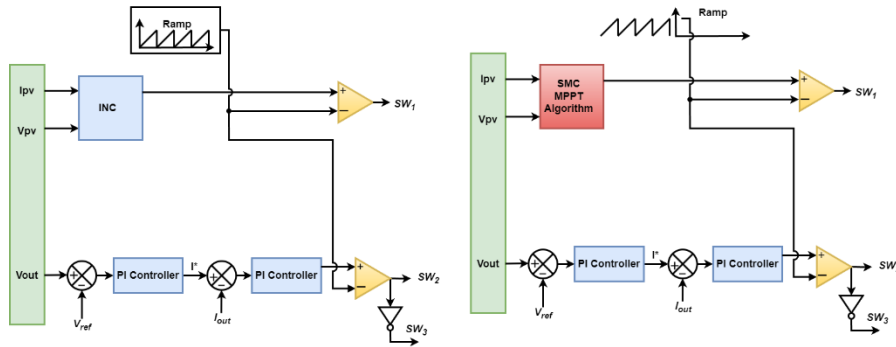

Figure 2.5: - control signal block diagram

As shown in the above figure, input to the MPPT algorithm is solar PV current (I_{pv}) and Solar voltage (V_{pv}). A PI controller is used to control the charging and discharging of the battery. The inner loop of the PI controller is a current loop, and the outer loop is the voltage loop. We have taken 50 volts as a reference voltage. The maximum current changes for different irradiations, but the maximum voltage is nearly equal. The MPP voltage is constant, and the current is variable. Tracking these voltages and currents is necessary for the algorithm.

B. Solar PV modeling

Solar cell characteristics resemble more with current sources. The double diode modeling accurately represents the PV cell, as shown in Figure 5. Double diode modeling considers the recombination effects inside the solar panel and provides better accuracy for the I-V curve. The model is complex and most accurate compared to the single diode model. In this model, the current sources are parallel to 2 diodes and lumped together with two resistance series and shunt resistance. The formula calculates the amount of current delivered by the solar cell. [7]– [9]

$$I_{pv} = I_s - I_{s1} \left\{ \exp\left(\frac{V_{pv} + R_{se} I_{pv}}{n_1 V_t}\right) - 1 \right\} - I_{s2} \left\{ \exp\left(\frac{V_{out} + R_{se} I_{pv}}{n_2 V_t}\right) - 1 \right\} - \frac{V_{pv} + R_{se} I_{pv}}{R_s} \quad (4)$$

here,

$$V_t = \frac{T_c K}{q} \quad (5)$$

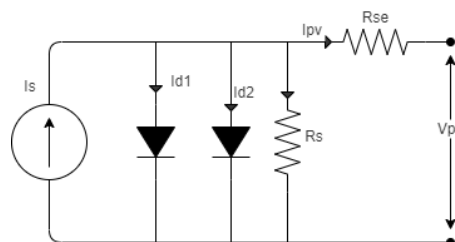

Figure 2.6: - equivalent circuit diagram of solar PV

- I_s = Reverse saturation current due to diffusion phenomenon.
- n_1, n_2 = Quality factor.
- I_{s1}, I_{s2} = Reverse saturation current due to diffusion and recombination phenomenon, respectively.

- R_s, R_{se} = Lumped shunt and series resistance respectively.
- T_c = operating temperature ($^{\circ}C$)
- k = Boltzmann constant.
- $q = 1.6 \times 10^{-19}$

C. *Different modes of operation*

In the above circuit topology, we can achieve various modes of operation. Modes are classified on the basis of power flowing in the load. For example, in cloudy conditions, the solar panel is insufficient to supply power to the load; therefore, the load gets power from both the battery and solar PV; at night, the load gets only power from the battery. There are a total of 4 modes of operation in the above given circuit topology. Due to this kind of circuit topology, there are many advantages: the system becomes reliable, excess power is stored, and the load gets continuous supply. Different modes are classified by comparing solar (P_{pv}) and load power (P_{load}). The PI controller decides the direction of the power flow. PI controller decided whether to charge or discharge the battery.

Mode1: -PV power (P_{pv}) is $>$ load power (P_{load}). Then extra power is sent to the battery, which is in charging mode. Load is getting power only from Solar PV. Battery current is negative. The state of charge (SoC) is increasing.

Mode2: -PV power (P_{pv}) is $<$ load power (P_{load}). Power from the PV is not sufficient to meet the load demand. In this condition, both the battery and PV are supplying the power to the load. The battery is in discharging mode. Battery current is positive. SoC is decreasing.

Mode3: -PV power (P_{pv}) is $= 0$, and load power (P_{load}) not equal to 0. In this condition, only the battery is supplying the load power, and the battery is in discharging mode. Battery current is positive. SoC decreasing.

Mode 4: -PV power (P_{pv}) is $=$ load power (P_{load}). Only PV is supplying the power to the load. battery is in inactive mode. SoC is nearly constant.

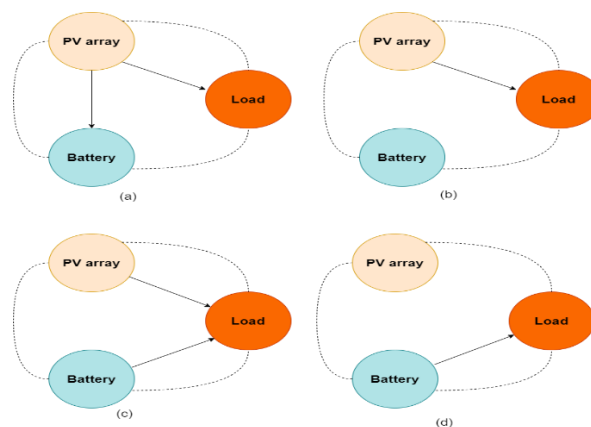

Figure 2.7: Modes of power flow under different irradiance conditions (a) When PV power is greater than load power, (b) PV power is nearly equal to load power, (c) When PV power is less than load power, (d)when PV power is equal to zero.

Different modes are explained in the above figure. The system consists of a PV array, battery, and load. Arrows in the figure show the flow of the power. Figure (a) shows that when there is a high value of solar irradiation, PV is sufficient to supply the load and battery power.

III. MPPT ALGORITHM

The main principle of maximum PowerPoint tracking is to stay on maximum PowerPoint, which is the matching of load impedance and source impedance to achieve. This impedance matching is done by adjusting the duty cycle of the converter. Incremental conductance deals with the slope of the PV curve, and the maximum power point is tracked by searching the peak value of the PV curve. There are some issues related to the incremental conductance, such as the failure to understand the MPP when solar irradiation changes from low to high.. In the INC algorithm, the instantaneous conductance (I/V) and the incremental conductance (dI/dV) for the MPPT are used to determine the MPP. [an improved]

At MPP the condition is,

$$\frac{dI}{dV} = -\frac{I}{V} \quad (6)$$

Where,

I and V are the current and the voltage of the solar PV.

III. DESIGN SLIDING MODE MPPT

A. SMC based MPPT

Sliding Mode Control (SMC) has garnered increasing attention as an alternative approach for MPPT in PV systems. SMC is a robust nonlinear control technique that does not rely on precise mathematical models, making it well-suited for handling the inherent nonlinearities and uncertainties in PV systems. Unlike conventional MPPT algorithms, SMC drives the system towards a designated sliding surface in the state space, maintaining the system near this surface to achieve desired performance objectives.

The advantages of SMC over conventional MPPT algorithms are manifold. Firstly, SMC offers robust performance in the presence of uncertainties and disturbances, ensuring stable operation under varying environmental conditions. Secondly, SMC exhibits fast response times and high tracking accuracy, enabling rapid convergence to the MPP without the need for extensive parameter tuning. Additionally, SMC mitigates issues such as oscillations and chattering commonly associated with conventional MPPT techniques, thereby enhancing overall system efficiency and reliability.

The sliding surface is given as: -

$$\sigma(v_{pv}, i_{pv}) = \beta v_{pv} + \gamma i_{pv} + kp = 0$$

The photovoltaic current at maximum power situation is given by $I_{ref} = 0.85 \cdot I_{pv}$ [4]. Whenever the inductor current i_L hits I_{ref} , the maximum power can be attained.

The duty ratio is given by

$$u_1 = u_{eq} + K\sigma$$

Where $Kp = 0.1$ and u_{eq} is given by

$$u_{eq} = 1 - \frac{v_{pv}}{v_o}$$

V_{pv} and V_o are PV voltage and output voltage of PV system respectively. The control law is set up always to satisfy the sliding condition. In the framework under consideration, I_{pv} and V_{pv} denote the input current and voltage, respectively. The delineation of the switching surface is predicated upon the parameters β , γ , and kp , serving as surface constants [11]. The augmentation of cell voltage necessitates a commensurate increase in the duty cycle. Thus, if $\sigma < 0$, the solar cell voltage should be optimized to yield maximal power output. Through the employment of Sequential Modified Clipping (SMC), the duty ratio of the converter is attenuated, aiming to diminish the cell voltage if $\sigma > 0$, thereby effectuating a transition of the operating point towards the Maximum Power Point (MPP). By modulating the converter's duty ratio, the system ensures continuous alignment with the MPP, signifying an optimal operating condition where $\sigma^* = 0$

IV. SIMULATION RESULTS AND DISCUSSION

The results are two algorithms that proposed SMC algorithm and INC algorithm by keeping all the parameters constant. we have done simulation for different irradiance condition. irradiance is varied in between 1000(w/m2) to 0(W/m2).

Table 4.1: Solar PV specification

Parameters	Value
Maximum Power	213.15watts
Cells per module	60
Open Circuit Voltage	36.3 V
Short circuit current	7.84A
Voltage at maximum power point	29 V
Current at maximum power point	7.35A

Table 4.2: Simulation parameters

Parameters	Value
Inductor	L1=L2=5mH
Capacitor	C1=C2=3300µF
Switching frequency	20KHz
Load resistance	10 Ω
Reference voltage	50 Volts
DC link capacitance	100µF

The control signal is given to the bidirectional converter through the double loop PID; the inner loop is current, and the outer loop is voltage. The PID control signal is shown in Figure 2.5.

Table 4.3: PI controller values

Parameters	Values
Inner current loop	Kp=5 , Ki=11
outer voltage loop	Kp=4 , Ki=11

Results are given under different varying irradiance condition. There is total two section, description of the section defines below,

- A. Output results of Proposed SMC algorithm under varying irradiance condition.
- B. Output results of INC algorithm under varying irradiance condition.

For both the algorithm results, irradiance has change according to the figure. We have taken sudden change in irradiance to check the robustness of the converter. we change the irradiance in step manner and kept constant for some time period. Initially the irradiance kept at 1000 (W/m²)

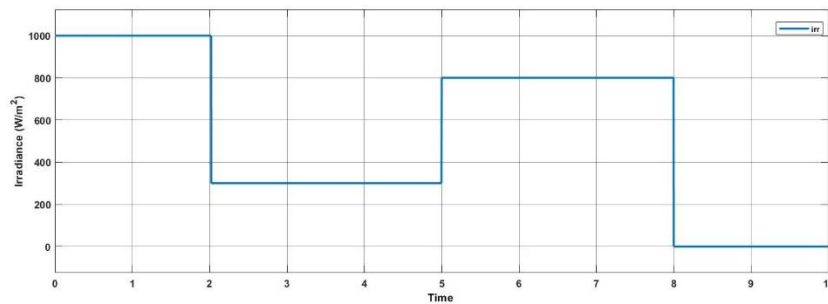

Figure 3.4: - Varying irradiance (1000,300,800,0(W/m²))

A. Using Proposed SMC algorithm

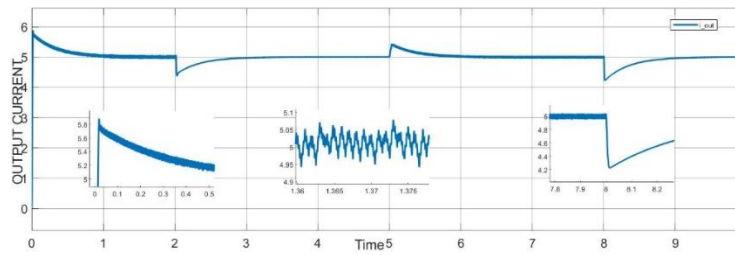

Figure 4.5: - load current (Amp) Vs Time (seconds) using proposed SMC algorithm

In the above figure 4.5 we can see that output current is nearly 5 amp there is sudden spikes in output current whenever there is sudden change in irradiation. There is maximum +5.8 and +4.2 current spikes. Maximum 16% of overshoot and -16% of under shoot.

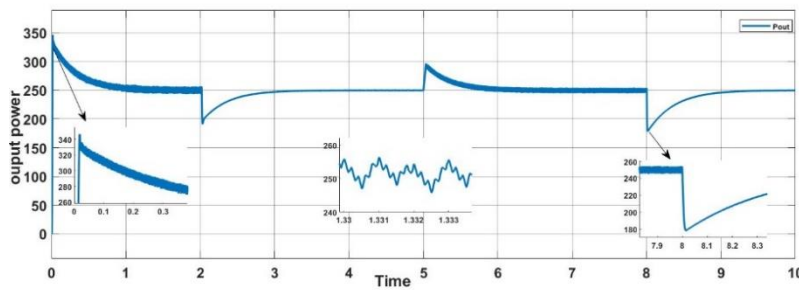

Figure 4.6: - Output power (Watts) Vs Time (second) using proposed SMC algorithm

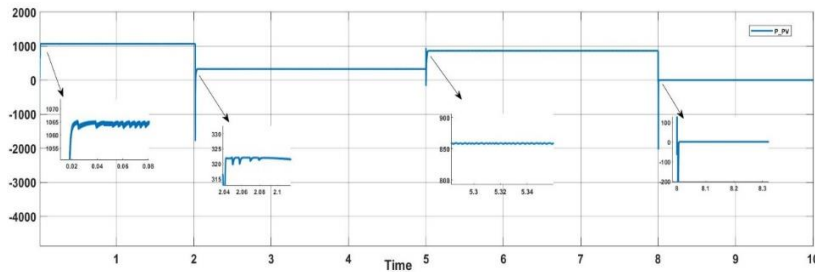

Figure 4.7: - Solar power (Ppv) in watts Vs Time (seconds) using proposed SMC algorithm

Solar PV power (Ppv) due to MPPT algorithm is nearly equals to the MPP as shown in the above figure.

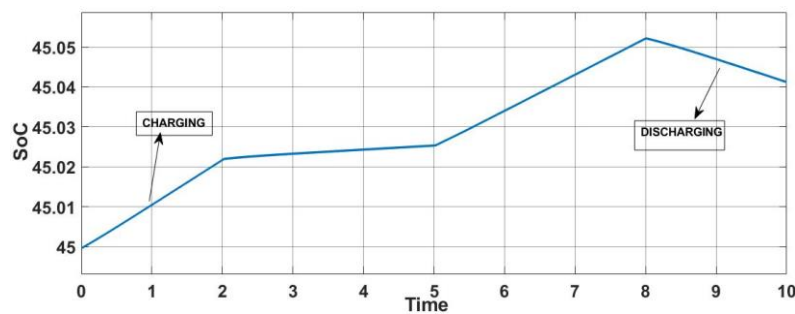

Figure 4.8: - SoC (%) Vs Time (seconds) using proposed SMC algorithm

Positive slope of the SoC indicates that battery is in charging mode and negative slope indicates that battery is in discharging mode. As we can see in the above figure 3.8 that whenever PV power is greater than the 250 watts battery goes into charging mode and below that of 250 watts goes into discharging mode.

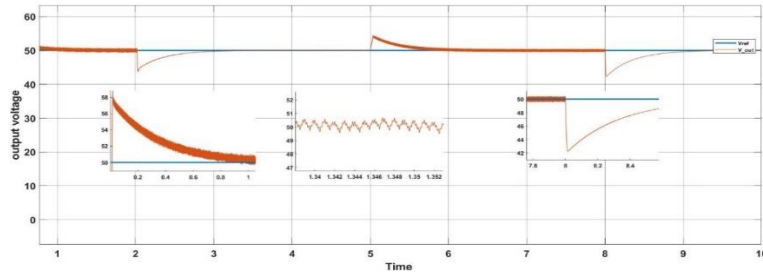

Figure 4.9: - Output voltage (volts)Vs Time (seconds) using proposed SMC algorithm

Output voltage shown in above figure with respect to time. It is clear that output voltage is nearly constant. There are sudden spikes whenever there is change in the irradiance. Maximum overshoot of 58 volts and undershoot of 42 volts

B Using INC algorithm

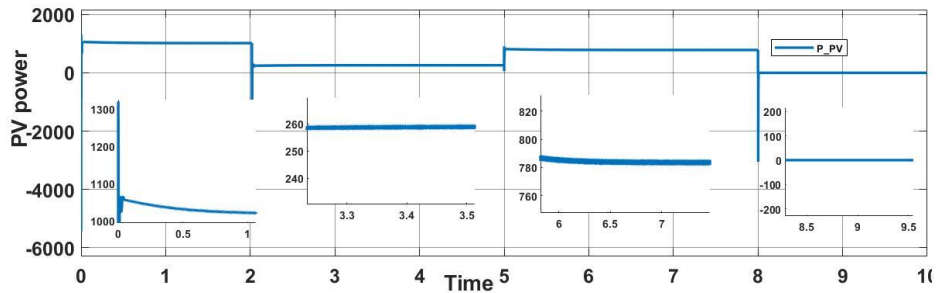

Figure 4.10: - PV power(watts) Vs Time (seconds) using INC algorithm

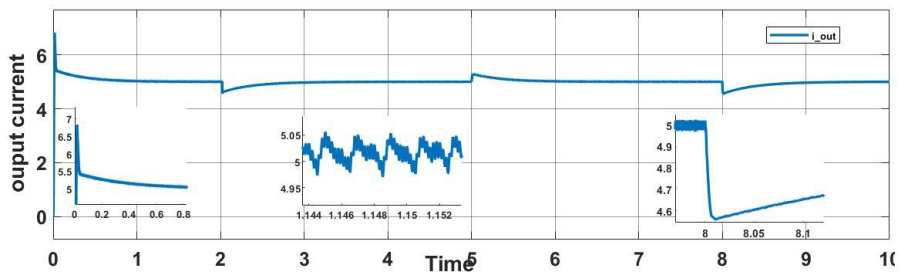

Figure 4.11: - Output current (Amp)Vs Time (seconds) using INC algorithm

From the above figure 4.11 it as we can see that output voltage is nearly constant and having a peak overshoot of maximum 6.8 Amp and 4.6 amp of undershoot. As we can see that there are sudden spikes during that step change in irradiance.

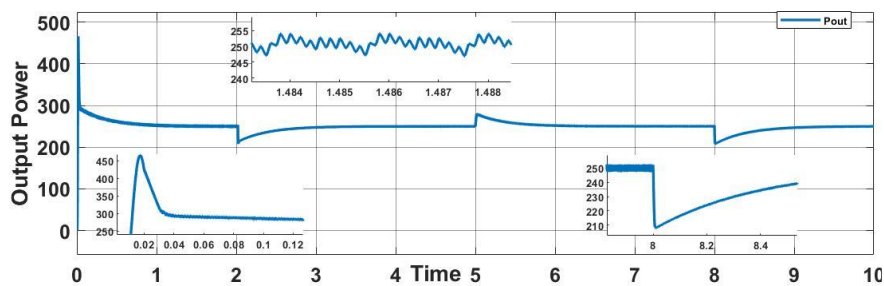

Figure 4.12: - Output Power (watts)Vs Time (seconds) using INC algorithm

In figure 4.12 we can see that there is spike of around 450 watts for 0.03 sec as we apply sudden change in irradiance

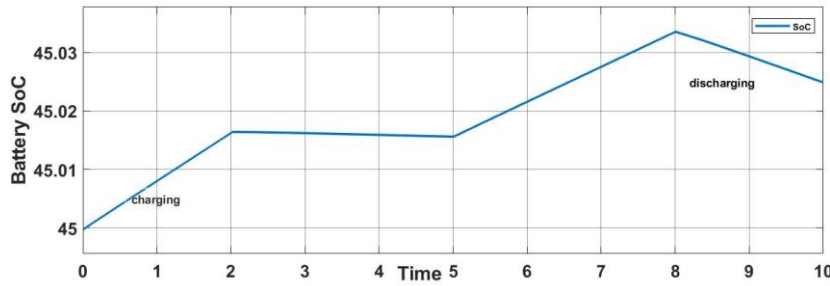

Figure 4.13: - SoC (%) Vs Time (seconds) using INC algorithm

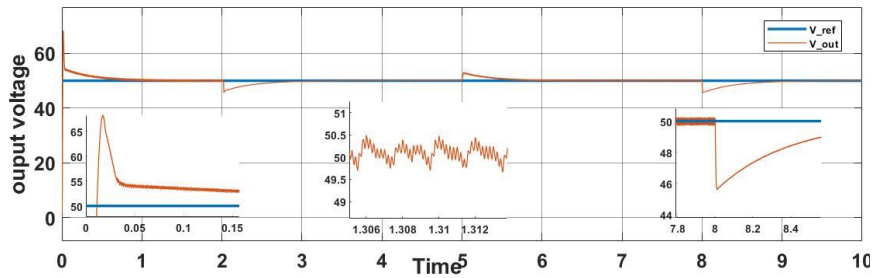

Figure 4.14: - Output voltage (volts) vs. time (seconds) using INC algorithm

The output voltage has a maximum overshoot of 68 volts and an undershoot of 46 volts. As we can see in figure 4.14 that output voltage shows spikes whenever there is a sudden change in irradiance, having a maximum overshoot of around 63 volts and undershoot of 45 volts.

Table 4.4: Power comparison for Proposed SMC, INC algorithm

Irradiance (W/m^2)	MPP (W)	Power by Proposed SMC Algorithm (Watts)	Power by INC(Watts)
1000	1065.75	1064	1020
800	860	858	800
300	321.95	320	300
0	0	0	0

As we can see using Proposed SMC algorithm output power is quite closer to the MPPT. Power loss in the INC algorithm is due to the oscillation near to the MPP. There are various algorithm present till date we can apply on this system and can see the results. some of the results are effective and efficient but problem in those algorithms is their complexity in nature

V. EXPERIMENTAL VALIDATION AND DISCUSSION

The experiment traces are carried out using DSP-based dSPACE-DS1202 (MicroLabBox) to validate the proposed controller technique. An analog to digital (A/D) converter of dSPACE 1202 takes input voltage in the range of 10 V. Therefore, both converters' input and output voltage are multiplied by 0.1 before feeding to an A/D converter. As the proposed method is a PWM-based scheme, a DS1202-DSP-PWM block is used, which converts u into a pulsating signal with the on-time equal to u and a desired set frequency. The recorded results are from a four-channel Techtronics TPS2024B digital storage oscilloscope (DSO). The laboratory prototype of a Dual in Single out converter is adopted to validate the proposed work as illustrated in Fig.5.1. The current sensor ACS721 from Arduino was used to sense the inductor current. The advantages of the proposed controller is demonstrated in this section with the experimental traces.

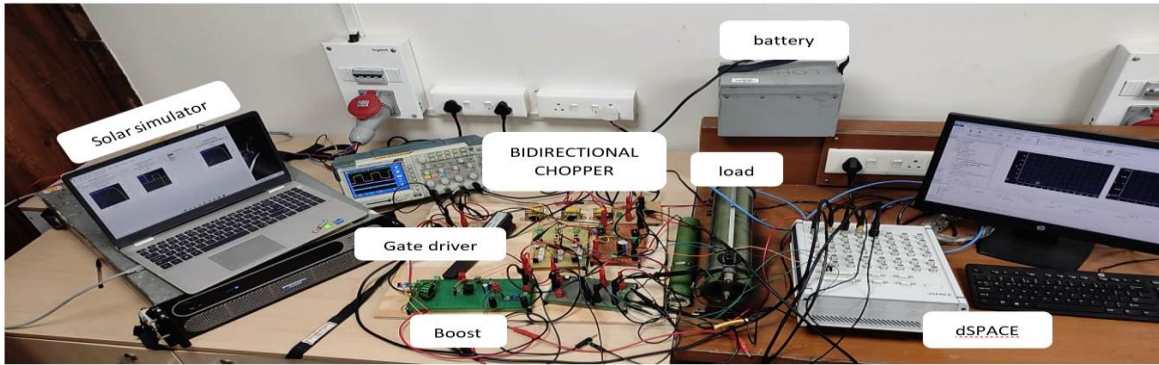

Figure 5.1: - Overall hardware setup

We have set up all the hardware as shown in the figure. We have used dSPACE to generate the gate pulse. The programming required for generating the pulse is done in MATLAB/SIMULINK. For reading the analog data from the system, we made a potential divider circuit. Two PCs are required in the overall circuit to control the solar simulator and the dSPACE.

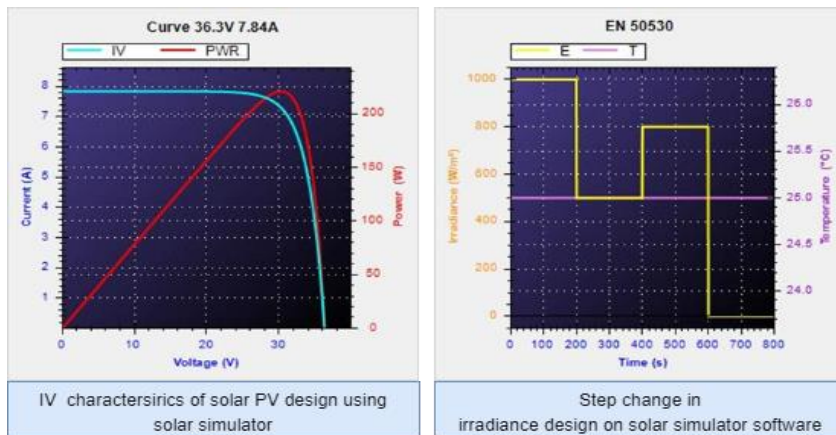

Figure 5.2: - Software view of TerraSAS software

The above figure shows the PV and IV characteristics of Solar PV, which we manually designed in the terraSAS software. The blue line indicates the IV characteristics and the red line indicates the power and voltage curve. The parameters are the same as those used in simulations.

The above figure is of variable irradiance. We design the irradiance as the simulation irradiance, keeping the temperature constant at 25 °C . The yellow line indicates the variable irradiance and the purple line indicates the constant temperature.

The ultimate objective is to control the output voltage; therefore, experimental results of output voltage and current are mostly shown in Fig.5.3 at steady state for constant input of 1000W/m² at constant temperature.

Fig. 5.4 shows the transient response of the boost converter under a change in input solar irradiation in a sequence of 1000W/m² to 1200 W/m² to 1000W/m². It can be seen that Solar PV voltage remains constant while Solar PV current increases as input solar irradiation are increases.

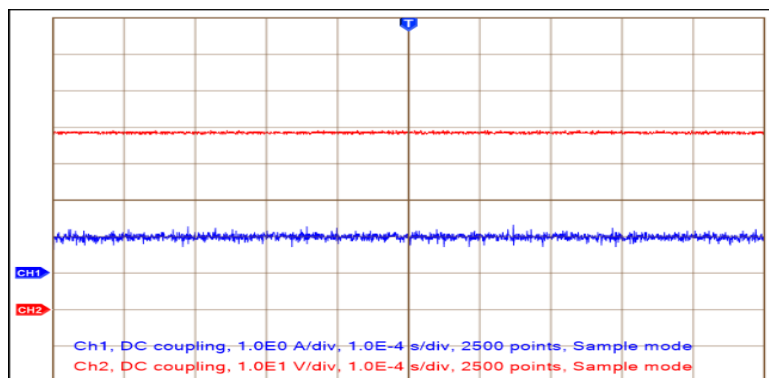

Figure 5.3: - Experimental waveforms of the PV voltage, current at 1000 (W/m²)

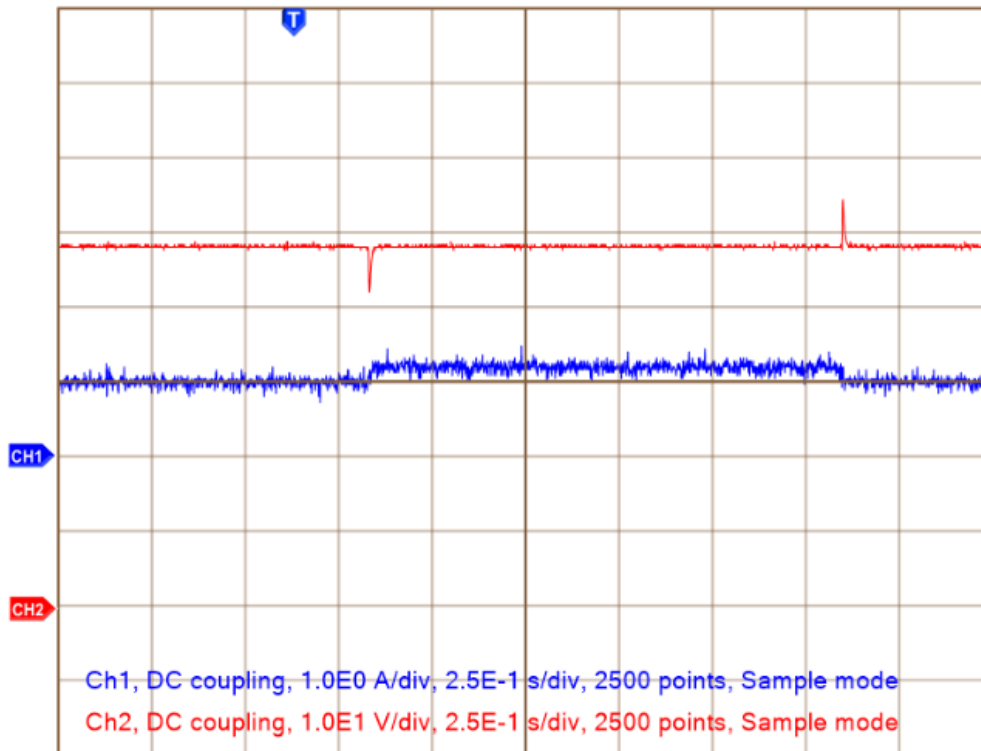

Figure 5.4: - Experimental waveforms of the PV voltage, current varying at $1000 \text{ (W/m}^2\text{)}-- 1200 \text{ (W/m}^2\text{)}---- 1000 \text{ (W/m}^2\text{)}$

CONCLUSION

In this research, the nonlinear SMC algorithm emerged as the superior choice for Maximum Power Point Tracking (MPPT) in photovoltaic systems. It exhibited enhanced stability, efficiency, and accuracy compared to the Incremental Conductance (INC) algorithm. SMC demonstrated superior transient response and minimized output current through the load, particularly during sudden changes in irradiance. Despite both algorithms satisfying operational modes, the proposed SMC consistently outperformed INC, showcasing smoother transitions and lower overshoot and undershoot. These findings underscore the significance of algorithm selection in optimizing photovoltaic system performance, highlighting efficacy in achieving desirable outputs under fluctuating inputs. Overall, this study emphasizes the pivotal role of MPPT algorithms in enhancing the reliability and efficiency of photovoltaic systems.

REFERENCES

- [1] S. A. Gorji, M. Ektesabi and J. Zheng, "Double-input boost/Y-source DC-DC converter for renewable energy sources," 2016 IEEE 2nd Annual Southern Power Electronics Conference (SPEC), 2016, pp. 1-6, doi: 10.1109/SPEC.2016.7846020.
- [2] L. Mitra and U. K. Rout, "Double input DC/DC converter with PV and DC source for standalone applications," 2016 International Conference on Microelectronics, Computing and Communications (MicroCom), 2016, pp. 1-5, doi: 10.1109/MicroCom.2016.7522553.
- [3] B. Z. Ghavidel, E. Babaei and S. H. Hosseini, "An Improved Three-Input DC-DC Boost Converter for Hybrid PV/FC/Battery and Bidirectional Load as Backup System for Smart Home," 2019 10th International Power Electronics, Drive Systems and Technologies Conference (PEDSTC), 2019, pp. 533-538, doi: 10.1109/PEDSTC.2019.8697731.
- [4] A. Elamathy and G. Vijayagowril, "Multiport DC-DC interleaved boost converter supplemented by hybrid system of different capacities PV and battery power system," 2015 2nd International Conference on Electronics and Communication Systems (ICECS), 2015, pp. 921-925, doi: 10.1109/ECS.2015.7125049.
- [5] A. Ali et al., "Investigation of MPPT Techniques Under Uniform and Non-Uniform Solar Irradiation Condition--A Retrospection," in IEEE Access, vol. 8, pp. 127368-127392, 2020, doi: 10.1109/ACCESS.2020.3007710.
- [6] S. H. Hanzaei, S. A. Gorji and M. Ektesabi, "A Scheme-Based Review of MPPT Techniques with Respect to Input Variables Including Solar Irradiance and PV Arrays' Temperature," in IEEE Access, vol. 8, pp. 182229-182239, 2020, doi: 10.1109/ACCESS.2020.3028580.
- [7] Smrity, A. Kumar, N. Bajoria and A. Alam, "Multiple-Input-Single-Output Converter for Hybrid Renewable Sources," 2019 International Conference on Vision Towards Emerging Trends in Communication and Networking (ViTECoN), 2019, pp. 1-5, doi: 10.1109/ViTECoN.2019.8899579.
- [8] F. Masmoudi, F. Ben Salem and N. Derbel, "Single and double diode models for conventional mono-crystalline solar cell with extraction of internal parameters," 2016 13th International Multi-Conference on Systems, Signals & Devices (SSD), 2016, pp. 720-728, doi: 10.1109/SSD.2016.7473725.

- [9] P. Sahu, D. Verma and S. Nema, "Physical design and modelling of boost converter for maximum power point tracking in solar PV systems," 2016 International Conference on Electrical Power and Energy Systems (ICEPES), 2016, pp. 10-15, doi: 10.1109/ICEPES.2016.7915898.
- [10] Lemmassi, Assiya & Aziz, Derouich & Hanafi, Ahmed (2020) "Comparative study of P& O and INC MPPT algorithms for DC-DC Converter Based PV System on MATLAB/SIMULINK," 1-5. 10.1109 / ICECOCS50124.2020.9314498.
- [11] N. Boujelben, F. Masmoudi, M. Djemel and N. Derbel, "Design and comparison of quadratic boost and double cascade boost converters with boost converter," 2017 14th International Multi & Conference on Systems, Signals & Devices (SSD), 2017, pp. 245-252, doi: 10.1109/SSD.2017.8167022.
- [12] R. B., Selvakumar AND C., Vivekanandan "Analysis of modified plug-in electric vehicle charger controller with grid support functionalities".2022 January,Public Library of Science.10.1371/journal.pone.026236
- [13] Shang, L., Guo, H. & Zhu, W. An improved MPPT control strategy based on incremental conductance algorithm. Prot Control Mod Power Syst 5, 14 (2020). <https://doi.org/10.1186/s41601-020-00161-z>