

<sup>1</sup>Shanker Bhattarai,\*  
<sup>2</sup>Aphirom  
 Promchanya,  
<sup>1</sup>Warangkana  
 Jutidamrongphan,  
<sup>1</sup>Kuaanan Techato,  
<sup>2</sup>Saroj Gyawali

## Linking Renewable Energy in Protected Areas for Sustainable Ecotourism Development

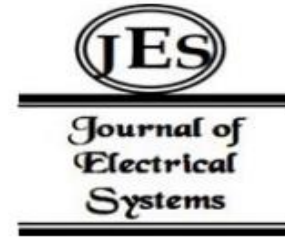

**Abstract:** The tourism sector has been booming in South Asia for several years. Many local people have also started tourism with traditional approaches in various protected areas and homestay places in Nepal. In recent years, the “sustainable tourism” approach has been prioritized too even from the community level. The interrelationship between “renewable energy” and “ecotourism” can be better explored by looking at the link between “renewable energy” and “environment” and “renewable energy” and “tourism” simultaneously. Thus, to know how the use of renewable energy has fostered sustainable Eco-tourism development, a systematic review is conducted to find all peer-reviewed articles in English published between 2009 and 2023 associated with the impact of the use of renewable energy for sustainable ecotourism development. The important databases “Google Scholar, JSTOR, and ScienceDirect,” search yielded 18,113 articles. Among 167 full articles, only 24 articles fulfilled our inclusion criteria. This comprehensive review concludes that integrating “renewable energy sources” into various aspects of tourism in protected areas not only transforms the tourism industry into eco-friendly ecotourism but also increases tourist arrivals ultimately fostering economic growth in the long run. Maintaining and protecting ecotourism and renewable energy is the process of the IoE and IED. These two new protection protocol technologies are decentralized to collect the data and store them in a safe and secure. The protocol helps to maintain sustainability without affecting the environment

**Keywords:** *Ecotourism, renewable energy, non-renewable energy, sustainable, development*

### INTRODUCTION

Tourism is widely recognized as a significant contributor to human welfare. It creates the employment opportunities for the local people, promotes local business while also serving as a catalyst for economic development in all advanced, emerging, and underdeveloped nations (Blažević, 2007).

World Tourism Organization (UNWTO, 2016) reported “The tourism sector is a rapidly expanding industry which plays a significant role in the global economy”. It constitutes about more than ten percent of the worldwide “Gross Domestic Product (GDP)”. “Ecotourism has been described in multiple ways. Ecotourism is a type of tourism that targets the environment to foster every community's development” (Prinsloo, 2015). Ecotourism is significant contributor to financial development, economic growth and environmental preservation (K.C, 2016).

Non-sustainable energy sources, such as “fossil fuels, coal, oil, and natural gas”, which make up approximately 80% of energy consumption, are increasingly being relied upon by the world (Hassoun & Mekidiche, 2018). The majority of the countries is in consensus that shifting to “renewable sources of energy” is an effective way of curbing

<sup>1</sup> Faculty of Environmental Management, Prince of Songkla University (Hat Yai campus), Hat Yai, Songkhla 90110, Thailand

<sup>2</sup> Faculty of Hospitality and Tourism, Prince of Songkla University (Phuket campus), 80 Moo 1, Vichitsongkram Rd., Kathu, Phuket 83120 Thailand

shankerbh@gmail.com<sup>\*</sup>, aphirom.p@phuket.psu.ac.th, warangkana.j@psu.ac.th, kuaanan.t@psu.ac.th, bsgyawali@gmail.com

\* Author to whom correspondence should be addressed.

“environmental damage” caused by “non-renewable energy” (Banga *et. al.*). However, the switch to renewable energy sources has been adopted lesser mostly in developing countries.

The energy as well as resource efficiency contribute towards enhancing the capacities of the firms as cited in Pace (2016) present the relation to sensing opportunities and threats in the environment, seizing of the opportunities, and managing and reconfiguring assets. These eventually contributed to the concerns associated with the need to enhance the prospects for integration of energy efficiency to that of sustainable tourism.

“Renewable energy comes from sources like water, wind, sunlight, plants, sea waves, and the heat often known as geothermal energy in the earth (K.C., 2016)”. These kinds of energy provide about 15-20% of the energy used in the world. The renewable resources provide social benefit such as improvement of health, advancement in technologies and opportunities for the work (Kumar, 2020).

The greater energy use in tourism largely centered on fossil fuel causes the impacts of hotel industries or tourism industries in general that have raised concerns through greater levels of greenhouse gases emission (Hall, 2013).

Basically, people have started to combine the ideas of using sustainable practices (called the green economy) with tourism. The UN made a set of guidelines to make sure this approach includes things like protecting the environment, using resources wisely, and treating people fairly. It's all about making sure everyone benefits and nothing gets harmed (Law *et al.*, 2016). The green economy is a comprehensive strategy that integrates economic growth and expansion with safeguarding the environment, adopting low-carbon practices, building pliability, promoting resource competence, supporting environmental “sustainability”, ensuring biological well-being, fostering all-inclusiveness, and achieving fairness.

This consideration largely considers the linkages of tourism with other sectors particularly making green economy holding important relevance in the conceptual model for transformation (Law *et al.*, 2016). However, Law *et al.* (2016) also points out the challenges in terms of its usage in the tourism sector through analysis of tourism value chain which involves the incorporation of tourism components to get to destination, within destination and importantly for the visitor and host communities, giving a holistic overview for promotion of sustainable tourism.

The current paradigm of travelling has shifted where due to growing environmental awareness and efforts towards sustainable lifestyle, a notable number of individuals are seeking ways to adjust their desire for extensive travel with their ecological beliefs. They are trying to find ways to do both sustainably. People must make sure everyone can travel without harming the environment. The widespread accessibility of sustainable travel is imperative and must be pursued through the implementation of renewable energy sources to power the entire industry. This means using renewable energy to fuel transportation. “Using eco-friendly and renewable sources of energy provides immense benefits not only for the environment, but also for the tourism sector” (Khan *et. al.*, 2021). Nonetheless, the discretion to incorporate such practices ultimately lies within the purview of individuals responsible for developing and utilizing tourism products and services.

Nepal with a rich cultural and biological diversity, has a potential to tourist attraction and flow each year. The tourism sector has been flourishing in Nepal since few years where the people have also initiated tourism in local level with traditional approaches. In recent years, the sustainable tourism approach has been prioritized too even from community level. The development of the tourism industry has caused an increment in vitality utilization and concerns around its sustainability. This study investigates the relationship between use “renewable energy” and “sustainable tourism”. Finally, the link between renewable energy consumption and ecotourism are discussed.

### **Research Aim**

Very few papers have explored the role of renewable energy for sustainable ecotourism development. Thus, this review intends to investigate all peer-reviewed journal articles related to the use of renewable energy for sustainable

ecotourism development. The primary research questions are listed below:

1. What are the concepts regarding eco-tourism, and development of eco-tourism?
2. What is the link between “renewable energy” and environment?
3. What is the impact of renewable resources on tourism and its development?

## Methodology

The researcher studied how renewable energy helps ecotourism by doing a review of lots of articles. The researcher used “Systematic Literature Review (SLR)” (Calderón-Vargas *et. al.*, 2022) as it allows the researcher to collect, sort and synthesize the information in a systematic manner.

According to Fink (2010), “A SLR is a systematic, explicit, comprehensive, and reproducible method for identifying, evaluating, and synthesizing the existing body of completed and recorded work produced by researchers, scholars, and practitioners”.

This research review followed the approach of Xiao and Watson (2017) which includes the following process:

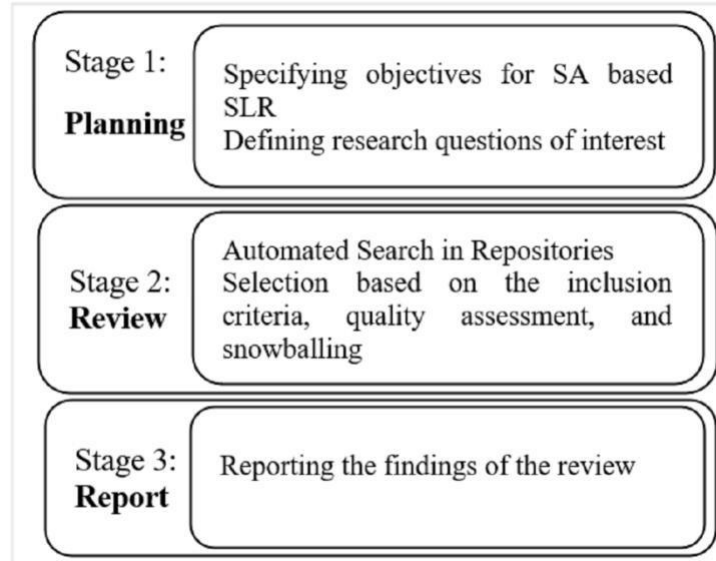

- a. **Planning:** The process entails the development of a clear problem statement, as well as the establishment and verification of a “review protocol”. The reviewers clearly identified the purpose and intended goals of the literature review and a review protocol was also developed by the reviewer.
- b. **Conducting:** It includes searching the literature in the available sources as such Google Scholars, Research Gate, developing inclusion criteria, specifying quality criteria, extracting the data from literature, analyzing and synthesizing the data.
- c. **Reporting:** At the end, the results and findings are represented. New insights should be highlighted. “The report findings should include also opportunities and direction for future research”, (Okoli and Schabram, 2010).

The keywords like “Ecotourism”, “renewable energy” searched on Google Scholar, JSTOR, ScienceDirect, Springer Open. When the principal phrase “use of renewable energy for sustainable ecotourism” was searched, it yielded 7283 results. Following the inclusion criteria, 15 relevant articles were selected for title, keywords and abstract screening.

**Research Framework**

There is many research work which links the interrelationship between “renewable energy and environment” and “tourism and environment”. There is lack of theoretical as well as empirical evidence about the nexus between use of renewable energy and ecotourism development. So, the research followed the following strategy:

Find the link between clean energy/renewable energy and carbon emission/environment

- a. Explore the relation between tourism and environment
- b. Finally, integrate role of renewable energy in ecotourism development

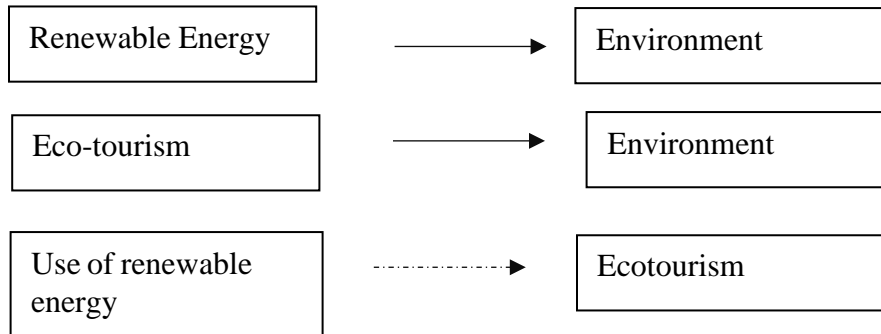

**Research Gap**

To conclude the above literature review, there is a lack of empirical findings for the impact of the renewable energy consumption on the tourism development. Many studies explore how “tourism development”, “carbon dioxide emissions”, and “renewable energy” are interrelated, but they neglect to consider their comprehensive relationship and the chance of a reversed cause and effect relationship. Similarly, many research endeavors in the field of renewable energies tend to concentrate on the exploration of sustainable practices within the domains of hotels and transportation. However, an area that warrants greater scholarly attention is the identification of sustainable practices in other sectors, in protected areas, exhibit significant energy consumption.

**Research methodology.**

As the model aims at creating a model that manages renewable resources and its variability and enables an effective management of the energy requirements through green sources. In most of the protected areas in tourism are characterized with PV systems and wind turbines. Hence, a based network is considered with their functioning being monitored by a protection scheme that helps in the proper functioning of the sources and improve sustainability. The protection scheme adopts two key methodologies for the monitoring and analyzing the functioning of the models. First is the IED (intelligent electronic devices), which is used to analyze the health of the devices and they transmit data about the sources to the IoE, Internet of Energy. The IoE is a pool where the data collected from the IED are stored and accessed by the protection scheme. These IEDs are connected to the main IoE through relays, and different IED are connected through different relay lines which enable the flow of data to the IoE. The Energy generated by the PV and wind energy systems are estimated and based on these values, the life-time of the devices is estimated and protection scheme optimizes the overall network for sustainability and longevity.

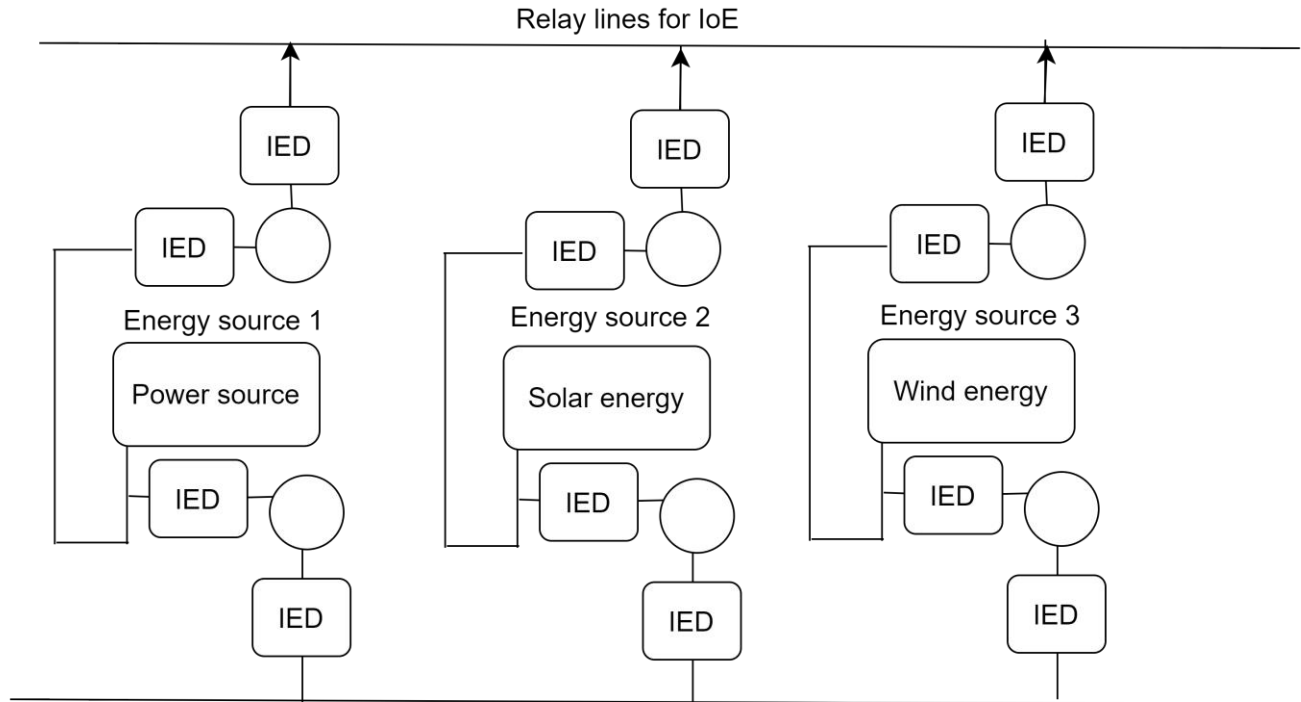

**Figure-2. IED and the power sources connected in series**

The figure-2 shows the overview of the model sources connected and series and how the IED is used to monitor the circuit and send data through relays to the IoE, which helps in optimizing the whole network.

### Protection scheme using IoE

In the upgrowing technology, the power configuration on multi-tapped and sub-transmission systems does not provide a well-protected storage device. Therefore, the introduction of a new method that is based on the feature of well-protecting configuration and a centralized networking system is called the IoE. An IoE is an automation and upgrade system for the conversion of electrical infrastructure from energy production. Thus, it led to consuming the least amount of energy waste more efficiently. Moreover, it is used to protect the ecosystem by conserving renewable energy. Considering a power plant has an IoE system to transfer energy through sub-transmission and transmission grid. To increase the usage of RRs by decentralizing the generators to meet the energy demands. Hereafter, to protect the grid domain the IED is referred to in the form of virtual levels. The increased number of IED dynamics will allow real-time telecommunication to fluctuate the generators and be decentralized. The IoE provides protection management in a system by helping ICT. The large amount of data collection can be communicated through the WiMAX technology.

Wireless Communication has been used in many applications because it provides a safe and secure communication network. One of the major applications is WiMAX technology, it helps to protect the simple circuits. This protocol is designed to overcome limitations in conventional protection schemes and protect complex smart grids. Thus, the protection method is presented with the use of a wireless protocol for the power configuration in multiple zones. The output of the method depends upon the sharing of data to distribute penetration generation. The maintenance cost and installation of this protocol can be reduced by a wide area network.

### Protection process

In this, there is an explanation of the protection in three major components, they are data sharing, the protection algorithm,

and data synchronization. The components of grid protection are data storing, data synchronization, directionality calculation, data sharing, and data reading. Initially, the IED is used to measure the data. With the help of WiMAX protocol, the data is sent to the grid domain protection. The second step is to process the data synchronization. The data obtained from IEDs are synchronized by the wireless network. It requires a time delay of  $2 \mu\text{s}$  to send the data. In the protection process, the directionality plays a huge role, as the selection of IEDs and the devices becomes crucial. The directionality is evaluated from the current signal, and it is calculated for the entire network. Based on that information, the faulty devices and sources can be identified and the rectified immediately,

$$DCE(j) = \sum_{j=k}^{k+n} |i(j) + I(j - n)| - \sum_{j=k}^{k+n} |i(j)|$$

In the above equation, the current signal is represented as  $i$ , recent fault  $k$ , number of sample  $n$ , directionality  $DCE(j)$ . The proposed protection scheme is adopted with renewable energy resources for improving the sustainability of the power sources. In the proposed model, PV system and wind power generation, and their variability is formulated. However, in real-world, based on the source of input, the proposed model can be scaled.

### Modelling solar PV systems for sustainable energy generation

The power output obtained from the PV systems are solely reliant on the type of environment it is setup. Depending on the solar radiation on the PV panels, the weibull distribution function can be used to estimate the power produced by the PV systems. Beta distribution function can also be used which processes the historical data, location and time, to estimate the power generated from the PV systems,

$$\alpha = \mu \left( \frac{(1 - \mu)\mu}{\sigma} - 1 \right)$$

$$\beta = (1 - \mu) \left( \frac{(1 - \mu)\mu}{\sigma} - 1 \right)$$

The probability density function is derived as follows,

$$f(s_i) = \frac{s(1 - s_i)}{\Gamma(\alpha)\Gamma(\beta)} \Gamma(\alpha + \beta)$$

The solar irradiance probability over any area at any specific time or duration is calculated using,

$$P = S = s_i = \int_{s_i, min}^{s_i, max} f(\zeta) d\zeta$$

Hence the total amount of solar output obtained is ,

$$(P_{mp}) = \frac{S}{S_{ref}} P_{mp,ref} (1 + \gamma(T - T_{ref}))$$

### Wind energy generator

The speed of the wind helps in estimating the performance and feasibility of the power output model. The amount of power output probability can be obtained through that. The random behavior of the wind can be obtained by weibull distribution, through which the random behavior of the wind is estimated. The weibull PDF is estimated through,

$$f(v) = \frac{k}{\alpha} \left( \frac{v}{\alpha} \right)^{k-1} \exp \left[ - \left( \frac{v}{\alpha} \right)^k \right]$$

Here, the following assumption that,  $v > 0, k > 0$ , and  $\alpha > 0$  , using wind speed  $V_m$  the following factors  $k$  and  $\alpha$  are estimated, and standard deviation of the model is measured as  $\sigma$ ,

$$v_m = \frac{1}{n} \left\{ \sum_{i=1}^n v_i \right\}$$

$$v = \left[ \frac{1}{n-1} \sum_{i=1}^n (v_i - v_m)^2 \right]^{0.5}$$

$$\alpha = \frac{v_m}{\Gamma \left( 1 + \frac{1}{k} \right)}$$

$$k = \left( \frac{\sigma}{v_m} \right)^{-1.086}$$

Figure 1, wind generator power output (P\_W), helps to calculate the output power,

$$P_w = \begin{cases} 0 & v \leq V_{ci} \\ K_{1v} + K_{2v}, & v_{ci} < v < v_r \wedge P_r, v_r < v < v_{co} \\ 0, & v \geq v_{co} \end{cases}$$

Where, before formulating the probability density function, the values of K\_1 and K\_2 are given  $\frac{P_r}{v_r - v_{ci}}$  and  $-K_1 v_{ci}$ , and finally the PDF is formulated in the following manner as,

$$P(P_{w,i} = 0) = P(v_0 \leq v < v_{ci}) + P(v_{co} \leq v) = \int_{v_0}^{v_{ci}} f(v) dv + \int_{v_{co}}^8 f(v) dv$$

$$P(0 < P_{w,i} \leq P_r) = P(v_{ci} \leq v < v_r) = \int_{v_{ci}}^{v_r} f(v) dv$$

$$P(P_{w,i} = P_r) = P(v_r \leq v < v_{co}) = \int_{v_r}^{v_{co}} f(v) dv$$

### Coordination logic

This logic plays an important role in the protection scheme. It is considered that numerous sources of energy generation are connected in series, and the relay connection helps to identify the faulty points and supplies. The relay points are the evaluation routes for the protection scheme to identify the faulty IEDs. There is the issue of relay not responding, and to overcome this issue, backup relays are connected to focus on the current points. Thus the proposed protection scheme monitors and finds the effective solution possible from the relays and obtains the information about the devices and relay lines in the circuit. This is a basic scheme adopted to protect the energy generating devices for better protection and sustainability improvement.

### Results and Discussion

The proposed model is implemented in Matlab, and the results obtained are compared with the existing ones. Initially, some of the important works considered for the estimation process are discussed and the usefulness of the proposed model is shown in detail. The protection scheme for the renewable energy sources in a protected area is needed as most of these areas consume more energy and are not environmentally sustainable.

### Dataset

For evaluating the model, a solar[65] and wind [66] dataset is considered. The solar dataset is collected from the solar power plant in Yeongam stadium, and the data covers over 3 years and 10 months. It consists of surrounding and surface temperature, solar irradiance and output power. The wind dataset NREL is gathered from New Kirk. This dataset consists of wind speed, direction, surface pressure, temperature and density.

### Overview of sorting and exclusion process

The major sources are JSTOR, ScienceDirect, Springer Open, and Google Scholars. Someresearches were both in all these sources, so research avoided duplicate research article and madesure relevant articles are reviewed. The table below shows how relevant articles were selected from different based on inclusion criteria.

Source	Total results	Articles included	Articles excluded	Criteria
<b>JSTOR</b>	429	4	428	Date of publication (2009-2023): 114 English: 112 Open Full text article: 19 Relevant: 4
<b>ScienceDirect</b>	879	3	876	Date of publication (2009-2023): 612 English: 612 Open Full-text article: 121 Relevant: 3
<b>Springer Open</b>	5	2	3	Date of publication (2009-2023): 4 English: 4 Open Full text article: 4 Relevant: 2
<b>Google Scholars</b>	16800	15	16785	Date of publication (2009-2023): 16800 English: 16800 Open Full text article: 113 Relevant: 15

### Concepts of eco-tourism, and development of eco-tourism

“Ecotourism is a tourism endeavor that centers on the environment to generate positive outcomes for the local community through changed behavioural efforts in living and operational activities” (Prinsloo, 2015). Ecotourism represents a principal subset of the “sustainable tourism sector”, with a particular emphasis on the “conservation of biodiversity”, the safeguarding of the “environment”, the amelioration of poverty, and the promotion of “economic advancement” (K.C, 2016). It is important because it helps to protect plants and animals, and it can also help improve the economy. The concept of “sustainable ecotourism” encompasses the effective management of biological diversity in the context of tourism activities aimed at providing a memorable and meaningful experience for tourists, while simultaneously engrossing retorting to the resulting pressures on the ecosystem. This ensures that tourists can enjoy the environment without causing harm to it.

When people travel to natural places, they should do it in a way that doesn't harm nature or the local culture. “Likewise, the concept of sustainable tourism involves a collection of strategies aimed at lessening the adverse impacts of traditional tourism practices on the natural environment and elevate the retention of the cultural authenticity of the host communities” (Baloch *et. al.*, 2023). Ecotourism is not just about looking at the environment and culture. It encompasses a range of practices, saving resources like water, recycling, and saving energy and the establishment of financial prospects for nearby communities.

The “ecotourism” promotes the preservation of diverse wildlife, economic growth within the community, “job opportunities”, sales of locally-made goods, and respectful interactions between guests and hosts. It strives to align “national tourism goals” with the needs of landowners by implementing a limited amount of direct benefit sharing and planning. This concept is widely acknowledged as a “catalyst” for promoting the advancement of “ecologically sustainable development”, which strives to establish a harmonious and symbiotic relationship with nature, local communities, and their respective cultures and customs.

The history of tourism in Nepal dates back to early 1949 with permit for mountain tourism. It is widely supposed that the origins of Nepalese “ecotourism” date back to the implementation of the “National Park and Wildlife Conservation



Act in 1973”. In Nepal, people like to go on ecotourism trips to see beautiful natural places like “national parks”, preservation zones, protected areas, and places that are cared for to protect the environment. They also like to see important cultural sites. Besides, village tourism aiding in activities such as forestation, agricultural transformation, conservation, income generation as well as exchange of culture and knowledge. The homestays within villages, buffer zones, conservation areas are gaining concern in recent time in Nepal (K.C.,2016).

#### Interrelationship between use of renewable resources and sustainable ecotourism development

Topics	Authors	Country	Conclusion
<b>Link between Clean energy/renewable energy and carbon emission/environment</b>	Attiaoui <i>et. al.</i> (2017)	North African Countries and Middle East countries (39)	“The association between renewable energy and environment is neutral.”
	Toumi and Toumi (2019)	Saudi Arabia	
	Saidi and Omri (2020)	China, India	“No association between renewable energy and environment.”
	“Azam <i>et al.</i> 2021; Mohsin <i>et al.</i> 2021; Liu <i>et al.</i> 2021; Xiaosan <i>et al.</i> 2021; Hdom 2019; Zhang <i>et al.</i> 2021; Saidi and Omri 2020; Bhat 2018; Toumi and Toumi 2019; Abbasi <i>et al.</i> 2021”	United States (USA), Canada, India, Iran, Japan, Russia, United Kingdom, South Korea, Germany and China, South Asian Economies, South America, Thailand	“Use of renewable energy reduces greenhouse emission and ultimately reduces environmental degradation.”

<b>Relation between tourism and environment</b>	Zhang and Liu (2019)	South East Asian countries and North Asian countries (10)	“Tourism has strong influence on environmental degradation.”
	Yue <i>et al.</i> (2021)	Thailand	“Tourism development positively affects carbon dioxide emissions.”
	Tian <i>et. al</i> (2021)	G20 economies	“1% increase in tourism decreases CO2 emissions by 0.05% in long run.”  “Renewable energy was having supportive role in CO2 emissions from G20 economies.”
<b>Role of renewable energy in ecotourism development</b>	Calderón-Vargas <i>et al.</i> , 2019	Peru	“Use of renewable energy for transformation and use in the development of sustainable museums and thus reduce environmental impact, contribute to the reduction of the carbon footprint. and sustainable tourism development.”
	Chen, 2011		“The implementation of renewable energy technology can be applied in the development of tourism,

			contributing to the reduction of carbon.”
	Waheed <i>et al.</i> , 2020	Saudi Arabia	“There is long-term cointegration between tourism, renewable energy, capital and economic growth.”
	Michalena <i>et al.</i> , 2009	Mediterranean islands	“The development of sustainable tourism is possible by using a multi-criteria analysis on renewable energies.”

From the above-mentioned table findings, it is unquestionable evidence that incorporating “renewable energy sources” is imperative to promote “sustainable development” across numerous segments and spectrums in tourism. The implementation of “sustainable energy sources” is the most effective means for nations to mitigate the effects of detrimental “carbon emissions”, while also fostering “sustainable tourism” and “economic development”.

According to Waheed *et al.* (2020), the integration of “renewable energy” technology holds promise in the advancement of tourism, whereby it may offer a substantial contribution to the mitigation of “carbon emissions”. “In the case of Saudi Arabia, the integration of tourism and “renewable energy” is essential for long-term co-integration between capital, economic growth, and sustainable development” (Khan *et al.*, 2019). The research highlights the pivotal roles that “tourism” and “renewable energy” play in driving “economic growth” within this region (Khan *et al.*, 2021). Khan *et al.* (2021) have put forth a recommendation that advocates for the integration of financial development in the tourism industry with the adoption of “renewable energy” and “ecological technologies” to increase the proportion of “renewable energy sources” in America.

This has eventually led to the emergence of integration of green economy with that of the tourism sector thereby leading to the development of criteria by UNDESCA (2012) that involves consideration of green economy as an approach that involved growth and economic development, environmental protection, low carbon development, resilience, resource efficiency, ecological sustainability, human wellbeing, inclusiveness, and equity (Law *et al.*, 2016). This consideration largely considers the linkages of tourism with other sectors particularly making green economy holding important relevance in the conceptual model for transformation (Law *et al.*, 2016). However, Law *et al.* (2016) also points out the challenges in terms of its usage in the tourism sector through analysis of tourism value chain which involves the incorporation of tourism components to get to destination, within destination and importantly for the visitor and host communities, giving a holistic overview for promotion of sustainable tourism.

The use of renewable energy in rural areas helps to reduce the environmental degradation thus, promoting ecotourism. The study conducted by Zhang and Liu (2019) revealed “a discernible connection between the tourism industry and environmental degradation in countries situated within the North and South East Asian region”. “The study revealed that the “tourism sector” is a leading cause of the rise in “carbon dioxide levels”, resulting in a considerable impact on the acceleration of climate change” (Calderón-Vargas *et al.*, 2022).

“Several studies have attempted to show that using renewable energy can lead to economic growth” (Banga *et al.*, 2022). Specifically, there have been investigations demonstrating that the consumption of renewable energy is associated with economic growth (Wang and Wang, 2020; Chen *et al.* 2020). Research in G20 nations found that as tourism grows, pollution decreases in the long term. This means that tourism is not the main cause of harming the

environment, but can help reduce pollution in these countries (Tian et. al, 2021).

Using clean and eco-friendly energy is better for the environment and helps preserve natural resources. Within the sphere of “environmental degradation”, the transition from non-renewable energy to “renewable energy” as a viable substitute energy source contributes to the preservation and perpetuation of the environment and its associated resources. Generation and efficient use of renewable energy could be one of the means for sustainable ecotourism development, especially in developing nation like Nepal. The use of renewable energy can help to control environmental degradation of natural resources (such as cutting trees for firewood; smoke and other types of pollutions) affecting the living and non-living organisms. Poudel and Joshi (2017) conducted the research in Annapurna region to explore the “renewable technologies” used and it had fostered the tourism of these places. This data on tourism levels and the energy sources or energy-saving technologies were collected from 489 tourist guesthouses located along three major Annapurna routes. The research found that by relying on “renewable energy sources” and locally designed energy-efficient technologies, the tourism industry witnessed a notable surge in its visitors. There was a noticeable difference in tourist arrivals in the "Annapurna region of Nepal" for guesthouses that could power their facilities with "renewable energy". The utilization of sustainable devices, such as “wind turbines and solar panels”, supply sufficient energy to isolated locations, resulting in an increased influx of visitors to these regions. Clean technologies also attracted more eco-tourists to the rural areas as tourists now perceive remote regions as more upscale than earlier times, and they consider “renewable energy” as a better alternative to using “paraffin or wood” for heating purposes.

K. C. (2016) also researched about the Ghandruk area to explore more about energy sources, biodiversity and tourism. Sustainable growth of “developing countries” like Nepal relies on the significance of “renewable energy sources”. The utilization of “sustainable energy sources” can improve the preservation of forests, increase the presence of vegetation and wildlife, promote the growth of “lush greenery”, encourage the adoption of “alternative energy” options, sustain the abundance of “natural resources” and foster “biodiversity” in "Ghandruk, as per K.C.'s findings in 2016. The introduction of “sustainable renewable energy technology” in Ghandruk that relies on tourism has resulted in the emergence of "nature tourism," commonly known as “eco-tourism”. The electricity, obviously, supplied and utilized by local residents comes directly from the sun and does not produce any pollution to the surrounding environment (Asyuri and Setiawan 2022). Li et al. (2022) investigated the ramifications of “non-renewable energy utilization” on both “ecological pollution” and economic endeavors. The significant findings revealed the negative impacts of fossil fuel consumption on environmental protection and green economic performances in China. Tian *et al.* (2021) “claimed posited that prolonged advancements in the development of tourism may result in a reduction of carbon emissions”.

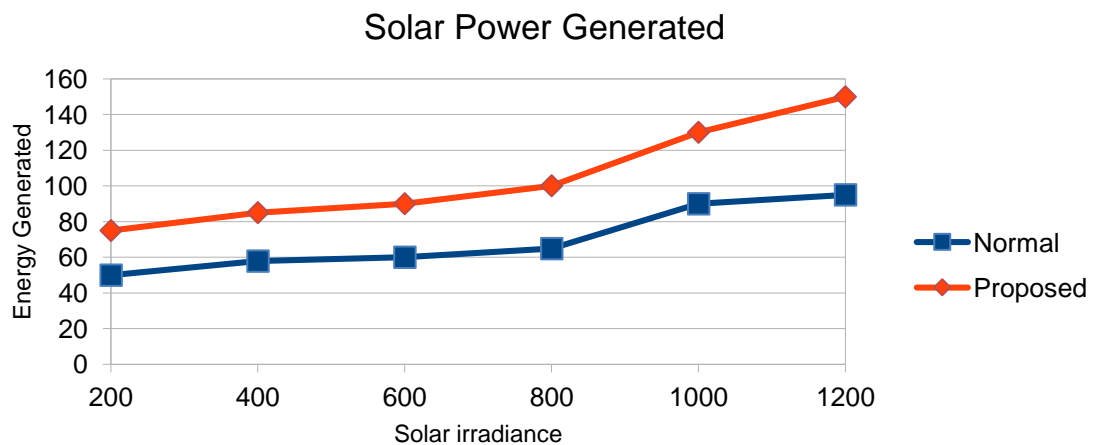
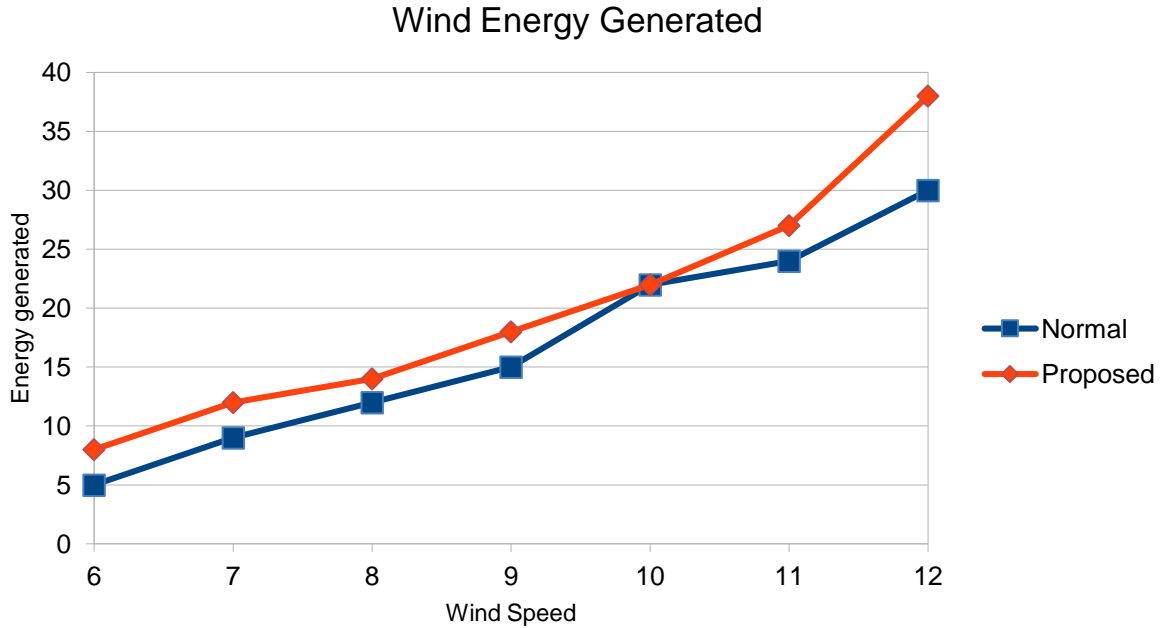

Figure-3. Increase in the solar energy with the proposed model

From Figure-3 it can be seen that, more energy is harnessed from the solar plant than the previous model due to the protection scheme adoption. This improves the overall energy generated by the plant and also optimizes them for real-world usage.



**Figure-4. Increase in the wind energy with the proposed model**

The same can be seen in figure-4, where the energy generated by the wind corresponding to its speed is very high. The proposed protection scheme with IED helps in the better optimization of the wind plants, and this helps in improving the overall performance of the model.

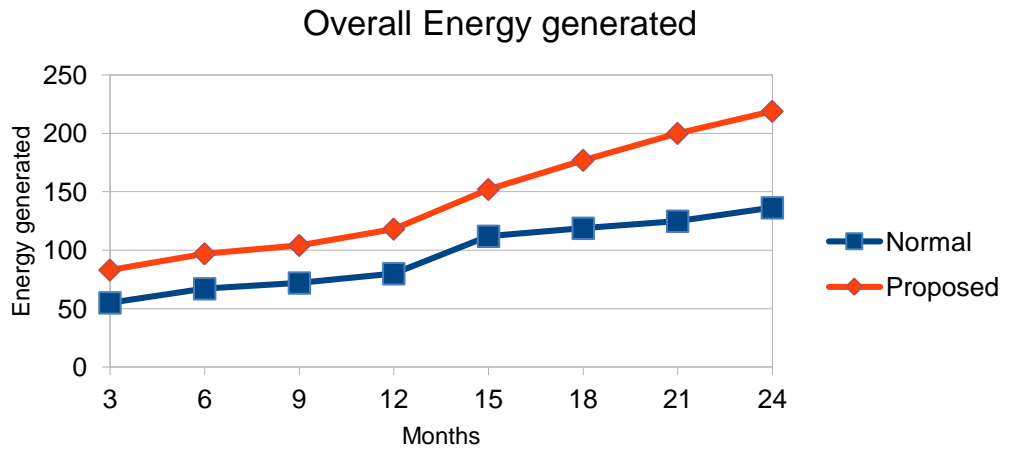

**Figure-5. Increase in the overall energy with the proposed model**

The figures 3 to 5 shows the performance of the proposed model over the normal energy consumption, from the simulated model. Through this, the model optimizes the energy consumption and also reduces the energy consumed from the main

source. The proposed protection scheme also improve the longevity of the circuits and improves the performance and sustainability of the environment.

### Conclusion

The researched using systematic literature review method, the aim was to explore the linkage between use of renewable energy and sustainable ecotourism. The available literatures were systematically and critically reviewed. This article reviews renewable energy in ecotourism and covers more than just hotels and restaurants. It's a reliable source of information, but it might not include everything. This research also serves as comprehensive foundation for to explore the roleof renewable energy in ecotourism in others sectors besides hotel and restaurants.

The utilization of “clean energy”, exemplified by sources such as “solar” and “wind power”, holdsthe potential to markedly contribute towards the progression of “sustainable tourism”. “The concept of “sustainable tourism” endeavors to alleviate any adverse effects that tourism may haveon the environment, society, and economy” (Banga *et. al.*, 2022). “The implementation of “renewable energy” sources can play a significant role in ameliorating “environmental degradation”, lowering emissions of greenhouse gases, and augmenting the sustainability of tourism-related pursuits K.C. (2016)”. It can reduce energy costs and increase energy efficiency, which can ultimately increase profitability. Additionally, it can enhance the reputation of a tourismbusiness, as more and more travelers are seeking environmentally responsible and sustainable tourism options.

A energy optimization model is proposed to incorporate renewable energy in the protected areas, to improve the sustainability and reduce the energy consumption. The proposed protection scheme uses IED and IoE for energy optimization. The model also estimates the energy generated by the energy sources and optimizes the usage of resources and checks for the failure of the devices in the plants. Through this model, the sustainability of the model can be improved. The proposed model also provides a incorporation for protected areas focused on improving the eco-tourism. From the results, it can be seen that the proposed model provides better optimization of the power plant and also increases the energy generated. It also increases the longevity of the energy generating resources.

### Compliance with Ethical Standards

#### Funding

No funding for this paper.

#### Conflict of Interest

The authors declare no conflict of interest.

#### Ethical approval:

This article does not contain any studies with human participants or animals performed by any of the authors.

### References

- [1] Abbasi K., Adedoyin. FF., Hussain. K. (2021), The impact of energy depletion and renewable energy on CO2 emissions in Thailand: Fresh evidence from the novel dynamic ARDL simulation. *Renew Energy*. 1439–1450.
- [2] Asyuri. R. K. and Setiawan. E. A. (2022), Optimization and Integration of Renewable Energy Sources with Regional Tourism Potentials to Improve the Welfare of Local Communities, *IOP Conference Series: Earth Environment Science*. 1050
- [3] Azam A, Rafiq M, Shafique M, Zhang H, Yuan J. (2021), Analyzing the effect of natural gas, nuclear energy and renewable energy on GDP and carbon emissions: a multi-variate panel data analysis. *Energy*. 119592.
- [4] Baloch, Q.B., Shah, S.N., Iqbal, N. (2023). Impact of tourism development upon environmental sustainability: a suggested framework for sustainable ecotourism. *Environmental Science and Pollution Research International* 30, 5917–5930
- [5] Banga. C., Deka. A., Kilic. H., Ozturen. A., Ozdeser. H. (2022), The role of clean energy in the development of sustainable tourism: does renewable energy use help mitigate environmental pollution? A panel data analysis. *Environmental Science and Pollution Research International*. 29(39):59363-59373.

- [6] Bhat JA. (2018), Renewable and non-renewable energy consumption—impact on economic growth and CO<sub>2</sub> emissions in five emerging market economies. *Environmental Science Pollution Research*. 35515–35530.
- [7] Calderón-Vargas. F., Asmat-Campos. D., Chávez-Arroyo. P. (2021) Sustainable tourism policies in Peru and their link with renewable energy: analysis in the main museums of the Moche route. *Heliyon*. 7(10) 8188.
- [8] Chen C. (2011) Researches on application of the renewable energy technologies in the development of low-carbon rural tourism. *Energy Procedia*. 1722–1726.
- [9] Hdom HA. (2019), Examining carbon dioxide emissions, fossil & renewable electricity generation and economic growth: evidence from a panel of South American countries. *Renew Energy*. 186–197
- [10] K. C. A. (2016). Ecotourism and Its Role in Sustainable Development of Nepal. In L. Butowski (Ed.), *Tourism - From Empirical Research Towards Practical Application.*, 31-59.
- [11] Khan, M.T.I., Yaseen, M.R., Ali, Q., 2019. Nexus between financial development, tourism, renewable energy, and greenhouse gas emission in high-income countries: a continent-wise analysis. *Energy Economics*. 83, 293–310
- [12] Khan. S., Quddoos. MU., Akhtar. MH., Rafique. A., Hayat. M., Gulzar. S., Yu. Z. (2021), Re- investigating the nexuses of renewable energy, natural resources and transport services: a roadmap towards sustainable development. *Environment Science Pollution Research International*. 13564-13579.
- [13] Li, W., Yu, X., Hu, N., Huang, F., Wang, J., Peng, Q., (2022), Study on the relationship between fossil energy consumption and carbon emission in Sichuan Province. *Energy Reports*. 8(4), 53–62.
- [14] Liu Y, Lin B, Xu B. (2021), Modeling the impact of energy abundance on economic growth and CO<sub>2</sub> emissions by quantile regression: evidence from China. *Energy*. 120416.
- [15] Metz. B., Davidson. O. R., Bosch. P. R, R. Dave, and Meyer. L. A., Contribution of Working Group III to the Fourth Assessment Report of the Intergovernmental Panel on Climate Change, 2007.
- [16] Michalena E., Hills J., Amat J.P. (2009), Developing sustainable tourism, using a multicriteria analysis on renewable energy in Mediterranean Islands. *Energy Sustainable. Development*. 13(2). 129–136.
- [17] Mohsin M, Kamran HW, Nawaz MA, Hussain MS, Dahri AS. (2021), Assessing the impact of transition from nonrenewable to renewable energy consumption on economic growth- environmental nexus from developing Asian economies. *Journal of Environment Management*. 111999.
- [18] Nepal. S.K. 2017. Tourism-induced rural energy consumption in the Annapurna region of Nepal. *Tourism Management*, 29
- [19] Pace, L. A. (2016). How do tourism firms innovate for sustainable energy consumption? A capabilities perspective on the adoption of energy efficiency in tourism accommodation establishments. *Journal of Cleaner Production*, 111, 409-420.
- [20] Poudel, B. and Joshi, R. (2020). Ecotourism in Annapurna Conservation Area: Potential, Opportunities and Challenges. *Grassroots Journal of Natural Resources*, 3(4). 49-73.
- [21] Saidi K, Omri A. (2020), The impact of renewable energy on carbon emissions and economic growth in 15 major renewable energy-consuming countries. *Environment Resource*. 109567.
- [22] Tian XL, Bélaïd F, Ahmad N. (2021), Exploring the nexus between tourism development and environmental quality: role of renewable energy consumption and Income. *Structural Changing Economic Dynamics*. 53–63.
- [23] Toumi S, Toumi H. (2019), Asymmetric causality among renewable energy consumption, CO<sub>2</sub> emissions, and economic growth in KSA: evidence from a non-linear ARDL model. *Environmental Science Pollution Research*. 16145–16156.
- [24] Waheed R., Sarwar S., Dignah A. (2020) The role of non-oil exports, tourism and renewable energy to achieve sustainable economic growth: what we learn from the experience of Saudi Arabia. *Structural Change Economics Dynamics*. 49–58.
- [25] Xiaosan Z, Qingquan J, Iqbal KS, Manzoor A, Ur RZ. Achieving sustainability and energy efficiency goals: assessing the impact of hydroelectric and renewable electricity generation on carbon dioxide emission in China. *Energy Policy*. 112332.
- [26] Yue XG, Liao Y, Zheng S, Shao X, Gao J. (2021), The role of green innovation and tourism towards carbon neutrality in Thailand: evidence from bootstrap ADRL approach. *Journal of Environmental Management*. 112778.
- [27] Zhang M, Yang Z, Liu L, Zhou D. (2021) Impact of renewable energy investment on carbon emissions in China-an empirical study using a nonparametric additive regression model. *Science Total Environment*. 147109
- [28] Zhang S, Liu X. (2019), The roles of international tourism and renewable energy in environment: new evidence from Asian countries. *Renew Energy*. 385–394.