

¹Shuo Shen,
^{2,*}Kehui Wu

Analysis of Teaching Mode of College Music Composition Theory Course Based on Data Analysis

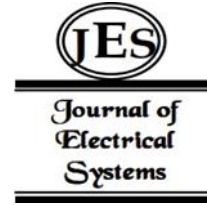

Abstract: - After learning the Soviet model and developing it today, the rudiment of professional music education established in the 1930s has formed the burden of various historical problems. At the same time, in the ideological collision between China and the West, various concepts and viewpoints around music teaching also appeared, but this is not the main research object because there is no answer at all; therefore, it is necessary to make more rational improvements to the relevant experience, new ideas and new ideas. Based on the theoretical basis of in-depth algorithm and constraint solving, this research starts from the current music teaching in colleges. It explores the curriculum mode that is conducive to the development of music in the author's country. The experimental results show that in the teaching mode of music composition theory courses in colleges and universities, the music composition optimization algorithm (MMC) has a profound impact on the teaching effect of the course. When solving Madcap's, the current optimal solution significantly impacts the results. In the curriculum problem, due to the constraints of the curriculum schedule problem, MMC does not show a promising solution effect but has good performance on the curriculum scheduling problem with relatively few constraints, so when solving problems with fewer constraints, the reader can choose MMC.

Keywords: Deep learning; Music composition Optimization algorithm; Music composition; Course teaching.

I. INTRODUCTION

To a certain extent, music can express the thoughts and feelings of the composer. At the same time, it can be integrated into the real life of society, bringing the listener into the musical atmosphere through the melody [1-2]. The teaching effect could be more apparent. In response to such a teaching situation, colleges and universities should optimize it from the perspective of reform to lay a solid foundation for cultivating students' musical literacy [3]. In teaching composition theory, teachers should fully consider students' actual learning situation and learning characteristics during music to improve the rationality and feasibility of teaching objectives. In this course, students need to understand essential knowledge points such as the components, expression methods, and expressions of voice music [4]. Music teachers should provide professional guidance and guidance to students so that students can form a correct understanding and understanding of the composition theory course from a clearer and deeper perspective to the study of this course.

Music teachers can divide the content of this course according to appropriate principles to form different teaching modules, improve the systematic nature of the teaching content enables the teaching content to be presented more intuitively and clearly in front of the students [5]. Under the general teaching situation, the content of college music composition theory courses can be roughly divided into four primary modules: music education, music culture, music creation and music performance. The interaction of these four modules forms a complete composition theory curriculum structure, dividing the entire composition theory curriculum into several teaching modules with distinct educational characteristics [6]. Among the four teaching modules, music culture embodies relatively fundamental theoretical characteristics. It contains less valuable content, while the other three modules embody the characteristics of combining theory and practice, which requires teachers to practice in practice. A highly valued matter in teaching activities [7-8]. In teaching activities, teachers should encourage students to integrate more innovative consciousness and ideas into composition creation and add richer musical elements to train students to create more high-quality musical works.

Therefore, in teaching music composition theory courses offered by colleges and universities, the rationality and pertinence of teachers' choice of teaching methods play an important role [9]. Influenced by traditional teaching concepts, many teachers will use relatively single and backward teaching methods to explain the content of composition theory courses to students. Such a teaching method cannot be fully applied to the

¹ School of Contemporary Music, Shandong University of Arts, Jinan250014, Shandong, China;

² School of physical education and music, Qilu University of Technology, Jinan250353, Shandong, China;

*Corresponding author: z00993@sdca.edu.cn;

teaching of music composition theory in modern colleges and even affects the effect of students' understanding of composition theory knowledge [10]. In response to such a teaching situation, teachers should innovate traditional teaching methods to keep students in composition theory course knowledge fresh. Under the principle of student subjectivity, teachers should give students more time and space in the classroom to explore the theoretical knowledge of composition independently or cooperatively [11]. For example, in the classroom, the teacher can ask a student to come to the podium in each class to introduce to the other students the type of music they prefer. In this process, teachers can infiltrate the theoretical knowledge of composition into students. Teachers can implement scientific grouping of students in the class and allow students to discuss the theoretical knowledge of composition through group cooperation. In addition, teachers can apply modern teaching methods to teaching activities and use multimedia teaching equipment to display some compositions, visual works and theoretical knowledge for students on the big screen. This kind of teaching mode has strong vitality, enabling students to participate more actively in the teaching activities organized by teachers to achieve the ideal teaching effect [13]. Genetic algorithms are currently recognized in the teaching of composition courses, which introduces a composition course teaching model formed by a self-attention mechanism.

In conclusion, analyzing the teaching mode of college music composition theory courses based on data analysis has theoretical and practical significance.

II. RELATED WORKS

First, in the search on the theme of “music education in normal colleges”, CNKI retrieved a total of 2,899 related literature. Excluding repeated publications and studies not related to this topic, the remaining 34 articles, including 19 journals and 12 master’s theses, and There are three conference reports. In this topic and related works of literature of this study, the author found that the research is divided into two directions. One of the pieces of literature is to study and analyze the characteristics and existing drawbacks of composition majors and composition-related courses from the perspective of music education in higher normal schools and put forward solutions to it. Through the analysis of this literature, we can find that the main points of this kind of research point that the composition major established under normal music education is different from music colleges, should have the characteristics of normal schools, and highlight the training. The goal is to “combine the composition technology theory course and art teaching practice for music education majors in normal colleges”. Learning composition theory, it is also necessary to combine music skills with practical applications [17].

On the other hand, the research in the other direction starts from factors such as the times, society and the relevant educational policies issued by the state. From the current situation of unequal emphasis on technology and culture, professional and teacher training, skills and aesthetics in normal music education, and educating people, the lack of links is expounded, and suggestions for strengthening culture, normal education, aesthetics and education are put forward in response to these problems [18].

In the literature review related to music education and this research, The author also divides the collected literature into three directions. First, it is based on the comparative study of teaching and conducts a comparative study on the training programs and methods of professional degree masters in China and the United States. The author starts with the classification of masters Beginning, the division of the American Master of Music degree and the training objectives of each category of master’s degree is expounded to analyze and determine whether the two research objects in this study are comparable. In this literature, the author was inspired to study the two schools as the research object. In the research of the analysis and comparison, the thinking on the comparability of the research objects [19]. The research conducted a comparative study on the cultivation of professional degree master’s in music disciplines in the two countries from five aspects: source of students, academic system, curriculum, training, and graduation, and put forward thinking and assumptions. However, the author’s research on this research model has the same and some differences. The thinking graduation method in the research is a level that the author did not think of when conceiving the research framework. This document fills the gaps in the author’s research [20]. In the comparative study of teaching, a comparative study of music teaching in China and the United States is also carried out. The author’s research

is closely related to Zhang Feiffer's literature in many aspects, so it is classified into the literature on composition and composition technology theory in the class.

Most of the literature on the courses related to the composition major is to start with the composition of the composition major and the curriculum modes and teaching materials for the courses of harmony, musical form, polyphony, orchestration, and computer music technology offered for the composition major. The current situation of the composition is analyzed, the existing problems are considered and explored, and pertinent opinions are put forward. In the research of the courses offered by composition, the idea of parallel theory and practice is put forward. "Practical", especially for the "most active and revolutionary" harmony, he believes that "by learning the classic harmony techniques in existing works" is to cultivate "creative" talents so that to advance the development of harmonics [21]. In addition to the research direction of teaching materials, the author also sorted out the literature from the direction of composition teaching and research. The article puts forward the view of "integrating the four major components of composition for teaching", while in "multi-voice music analysis and teaching", The course of "writing" is a concrete embodiment of the integration of the four major elements in actual teaching. In addition, they raise and discuss the opening of this course in four ordinary universities in Shanxi analysis and research.

MMC is a social algorithm that adjusts the creative process through changes in the social environment [22-23]. The general social algorithm is only adjusted according to the social environment, but the uniqueness of MMC is that it adjusts according to the knowledge of both the social environment and its own information. MMC simulates the creative process of composition.

To sum up, there are few papers related to MMC at present, and the applied problems include continuous optimization problems, constrained optimization problems, multi-objective problems, multi-sequence comparison methods and resource-constrained project scheduling problems [24]. Some scholars have studied the influence of the MMC social network on the performance of the algorithm, and some scholars have proposed a hybrid method of MMC. This shows that MMC can solve not only continuous optimization problems but also has great potential in discrete problems and combinatorial optimization problems.

III. COUPLING OF MUSIC COMPOSITION OPTIMIZATION ALGORITHM AND COURSE TEACHING

Since this paper mainly uses the MCC optimization algorithm to analyze the teaching mode of college music composition theory courses, we can define a new algorithm as the teaching algorithm. It stimulates the teaching process of composition courses to find the optimal global solution [25]. Compared with other meta-heuristics, it has the advantage that it only needs to control the number of populations and the number of iterations and does not need to adjust the specific parameters of the algorithm. In this algorithm, all learners are viewed as a population, and the lessons that teach learners are viewed as different variables in the solution of the optimization problem. The learning effects of learners correspond to their respective objective function values. The teaching algorithm and learning algorithm mainly include the teacher stage and the learner stage.

At this stage, teachers try to improve the average grade of the courses taught in the composition class based on their own knowledge. At the teacher stage, learners will improve their own level and enhance the concentration of search by learning from the teacher and under the influence of the average level of the class. Suppose there are K learners in the class, and each learner needs to study J courses. It can be seen that the number of populations is K, each solution contains J variables, and the solution in the problem is in the form of a vector, which represents the learner's grades in each subject $x = \{x_1, x_2, \dots, x_J\}$, $f(x)$ represents the overall performance of the learner. In each iteration, use Mean_j^i to represent the class average for the jet subject in the itch iteration, which is:

$$\text{Mean}_j^i = \frac{1}{K} \sum_{k=1}^K x_{k,j}^i \quad (1)$$

$$x_{\text{newk},j}^{ii} = x_{k,j}^i + \Delta_j^i, j \in [1, J] \quad (2)$$

If the quality of the new solution $x_{newk,j}^{ii}$ is better than that of $x_{k,j}^i$, $x_{newk,j}^{ii}$ will replace $x_{k,j}^i$; otherwise, it will not be replaced. For the learners of composition course teaching, not only can they learn knowledge through the teacher's teaching, but also improve themselves through mutual discussion among the learners in the classroom.

Randomly select an objective function value $f(x_A)$ corresponding to learner A, and the update rule of the solution is as follows:

$$x_{newk,j}^i = \begin{cases} x_{k,j}^i + \text{rand}(0,1) \times (x_{A,j}^i - x_{k,j}^i), & f(x_k^i) > f(x_A^i) \\ x_{k,j}^i + \text{rand}(0,1) \times (x_{k,j}^i - x_A^i), & f(x_k^i) \leq f(x_A^i) \end{cases} \quad (3)$$

The core of the teaching mode analysis is a set of classes responsible for local search for different aspects. Users can write derived classes according to the framework to obtain some methods. Some user-defined classes simply do the job of describing a specific problem, regardless of algorithmic control information. Relationships between classes and the invocation of interaction methods can be handled by the framework. The abstract structure of some classes fully reflects object-oriented characteristics. The implementation of the framework mainly adopts two methods: template method and strategy method. The template method specifies and implements the invariant parts of various search algorithms. The template classes used in this framework include Input, Output, Move, and State; the strategy method provides conditions for the main solver to call related component classes. The Helpers file holds the code describing the problem and the specific actions to perform the search. In the case of compound searches, multiple Neighborhood Explorers can be combined. Classes cooperate with each other in Helpers files. For example, the Neighborhood Explorer class does not have cost function calculations and needs to delegate to the Stage Manager class that handles state properties. It should be noted that the classes are in internal data and need to rely on Runners for data operations. As shown in Figure 1.

Solvers			
	SimpleSolver	Token-ringSolver	⋮ ⋮
Runners			
	HillClimbing	TabuSearch	SimulatedAnnealing
Helpers			
	State manager	Neighborhoodexplorer	⋮ ⋮
Input	State	Move	Output

Fig. 1 Abstraction level of teaching algorithm

For example, when we use the abstract local search algorithm of Easy Local+, we need to define the moving strategy (Select Move function), the accepting strategy (Acceptable Move function) and the criteria for stopping the search (Stop Search function).

The main classes that make up the core of Easy Local+ are shown in Figure 2. The class of the normal font is the interface used by the user in the framework Easy Local+, which is used to directly derive the user's concrete class. Classes whose names are in italics are the base classes of other classes in the Easy Local+ framework. As can be seen from the figure, the templates shared by the class hierarchy exist only in the base class.

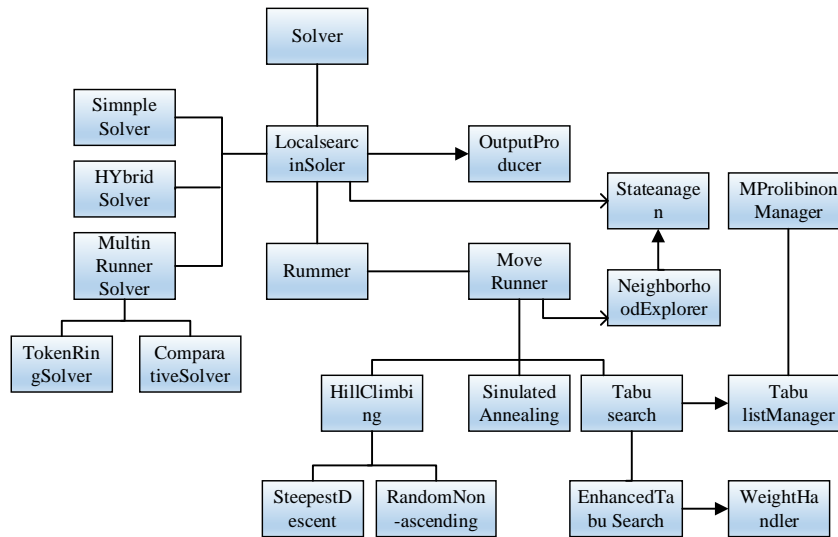

Fig. 2 The core classification of teaching algorithms

Therefore, we use a method called one-hot encoding for the representation of pitch. This encoding method has only one valid bit at any time. Usually, the invalid bit is represented by 0, and the valid bit is represented by 1. The effect of using one-hot encoding for a MIDI pitch sequence [59, 60, 61, 62, 71] is shown in Table 1. When using MIDI music composition theory course, there are 129 independent states in one-hot encoding. It needs to be represented by 129 bits, that is, the one-hot encoding of each pitch is a 129-dimensional 0-1 vector, and each pitch activates one of the status bits. For example, central C is encoded as 60 in MIDI, then its corresponding one-hot encoding result is that the 60th bit in the vector is 1, and the rest are 0.

Table 1: Coded representation of partial pitch

Pitch sequence	Pitch type	Single hot coding sequence
59	129	$\underbrace{000\dots000}_{58\text{Bits}0} \ 1_{59\text{th}} \ \underbrace{000\dots000}_{70\text{Bits}0}$
60		$\underbrace{000\dots000}_{59\text{Bits}0} \ 1_{60\text{th}} \ \underbrace{000\dots000}_{69\text{Bits}0}$
61		$\underbrace{000\dots000}_{60\text{Bits}0} \ 1_{61\text{th}} \ \underbrace{000\dots000}_{68\text{Bits}0}$
62		$\underbrace{000\dots000}_{61\text{Bits}0} \ 1_{62\text{th}} \ \underbrace{000\dots000}_{67\text{Bits}0}$
71		$\underbrace{000\dots000}_{70\text{Bits}0} \ 1_{71\text{th}} \ \underbrace{000\dots000}_{58\text{Bits}0}$

In the two common types of problem classification and regression in machine learning, the measurement of distance or similarity between features is the key point. In addition, one-hot encoding has the advantages of a simple encoding process and low encoding cost, as shown in Figure 3, which is also one of the highlights of this study.

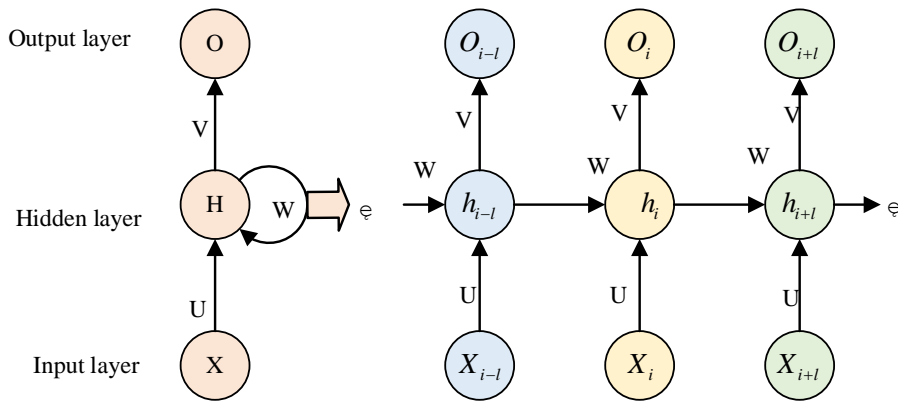

Fig.3 Encoding diagram of note feature vector

IV. METHODS

All the notes in modern conventional musical compositions can be found in the 128 numbers defined by midi. So 128 contains the number of all notes. For any note, there is a corresponding number. As shown in Figure 4, the center c, the corresponding number is 72.

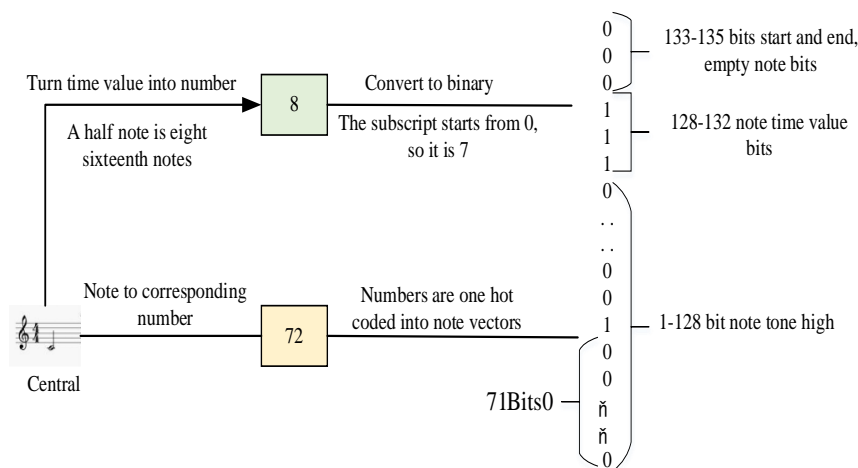

Fig.4 Schematic diagram of teaching coding of composition course

In One-hot encoding, among the first 128 digits, the 72nd digit is 1, and the rest are 0, indicating the pitch of the current note. At the same time, each note has its beat that represents the time value of a note. For each piece of music, the smallest unit of time value is used as the basic time value, and other notes can be represented by it. Such as: quarter notes, represented by sixteenth notes, for four sixteenth notes. In one-hot encoding, the sixteenth note is 0, the quarter note is 3, converted to binary, the sixteenth note is 0000, and the quarter note is 0011. So, 128-132 digits represent the rhythm of the note. In the seq2seq model, due to the unequal length of the sequence, the start of the sequence needs to be marked, the end of the sequence needs to be marked, and the empty vector is also marked. The 135-bit number is 1, indicating that it is currently an empty vector and contains no information. Through the above processing, each note can have a unique representation in the sequence.

In One-hot encoding, among the first 128 digits, the 72nd digit is 1, and the rest are 0, indicating the pitch of the current note. At the same time, each note has its beat that represents the time value of a note. For each piece of music, the smallest unit of time value is used as the basic time value, and other notes can be represented by it, such as quarter notes, represented by sixteenth notes, for four sixteenth notes. In one-hot encoding, the sixteenth note is 0, and the quarter note is 3; converted to binary, the sixteenth note is 0000, and the quarter

note is 0011. So, 128-132 digits represent the rhythm of the note. In the seq2seq model, due to the unequal length of the sequence, the start of the sequence needs to be marked, the end of the sequence needs to be marked, and the empty vector is also marked. The 135-bit number is 1, indicating that it is currently an empty vector and contains no information. Through the above processing, each note can have a unique representation in the sequence.

In addition, what kind of musical structure is the motivation introduced in the previous section. Since the amount of motivation data is too small, the motivation in the existing music data set must be manually annotated.

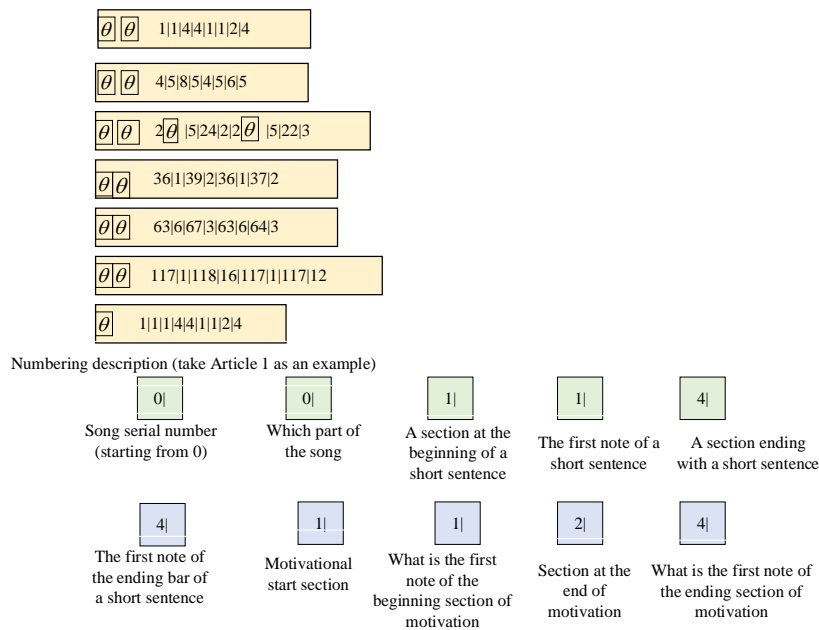

Fig.5: Composition course labeling form

Among them, short sentences are divided into three types because of the different structures of motivation: 1. Short sentences are generated by repetition of motivation. 2. Through repetition of motivational structures, pitch changes produce short sentences. 3. Generate short sentences by expanding the motivation. To do this, you need to label all three types. The motivation is shown in Figure 6.

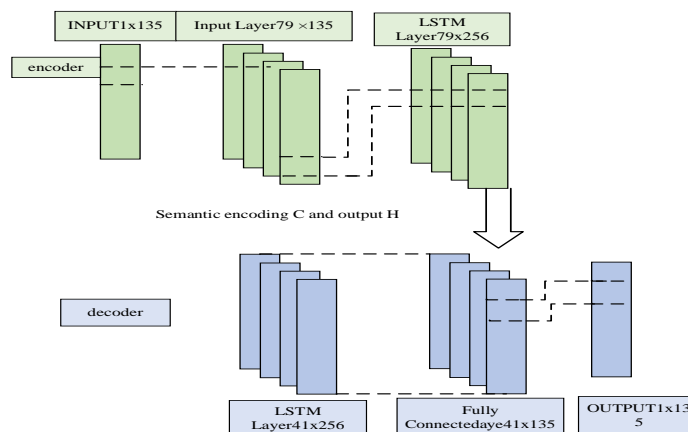

Fig. 6 Motivation extraction from the composition course model

Bring the one-hot encoded short sentence sequence into the seq2seq model. In the encoding stage in the seq2seq model, the LSTM network will pass the feature of each is in the short sentence sequence S backwards in time order, and finally pass out the unit state c and the output value h, these two are extracted in the encoding stage. short-sentence features. The steps are shown in Figure 7.

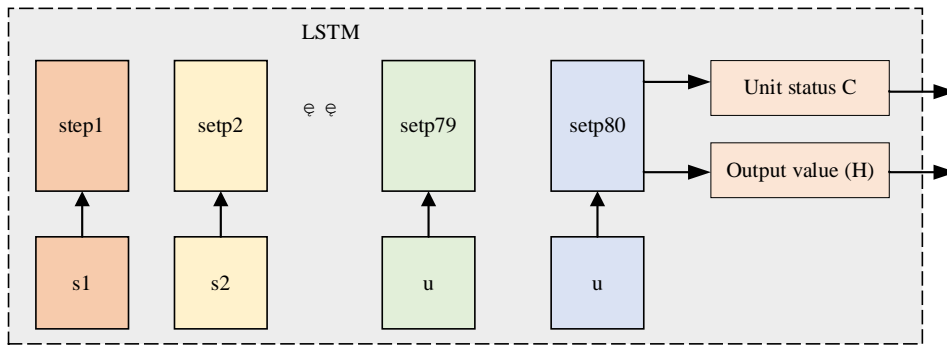

Fig.7 Encoding stage of short sentence sequence

The motivation sequence used as the input of the decoding stage also needs to add the start vector b (the start vector is a vector with 133 bits of 1, and the rest of the bits are 0); as the motivation sequence for the loss calculation in the decoding stage, the end vector e needs to be added (the end vector is 134 bit and the remaining bits are 0). It is assumed that the longest motivation sequence in the data set is 30, so motivation M is also complimented. The decoding stage during training is shown in Figure 8.

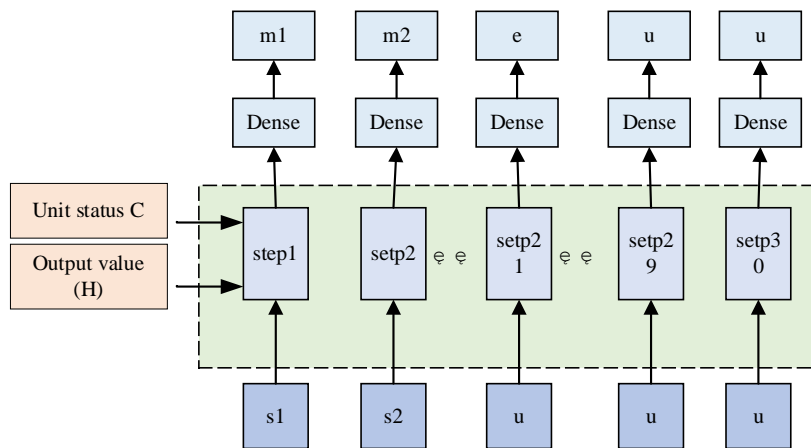

Fig 8 The stage of training and decoding in the composition classroom

The decoding stage is when generating motivation. When we need to generate motivation, when we pass the cell state c and output value h as initial values into the LSTM in the decoding stage. The seq2seq implementation of motivation extraction requires a note-by-note prediction, so in the decoding stage, we input the start vector b to predict the first note. The next step is to use the predicted 'm1' as the next input and pass the unit state c and output value h obtained in step 1 as the initial state to the next prediction to complete the prediction. By analogy, when the end vector e appears, it means the prediction is over. The steps are shown in Figure 9.

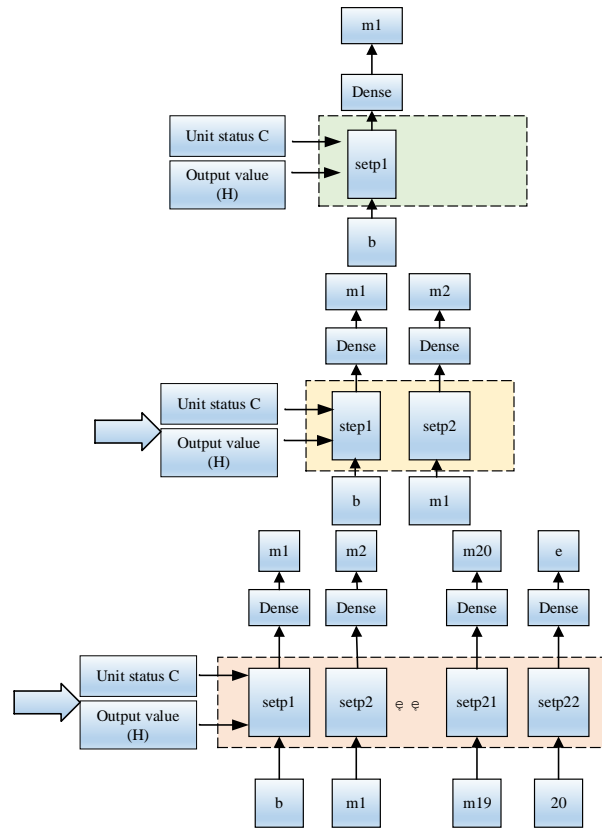

Fig. 9 Decoding stage when generating motivation

The composition class selected for this experiment is the appreciation of works by Mozart and Beethoven. Since the data sets of the two composers have a strong melody, the motivation is obviously very suitable for the motivation data set. The dataset has 2000, Mozart 300, and Beethoven 1700. Due to the small amount of experimental data, it is necessary to expand the data set, transpose each data, such as C major to D major, and finally get 14,000 data. The motivation is divided into three categories according to the type, the repetition of the motivation, the repetition of the motivation structure, and the extension of the motivation. Since the short sentences formed by the motivational repetition are also the motivational structure repetition, during the training, the motivational repetition data set is incorporated into the motivational structure repetition. The types of datasets are shown in Table 2:

Table 2: Mozart and Beethoven's works appreciation class dataset

Dataset type	Number of data sets	Maximum length of short sentences (number of notes)	Maximum length of motivation (number of notes)
Motivation repetition (training set)	1681	47	24
Motivation repetition (test set)	421	47	24
Motivation structure repetition (training set)	8001	47	24
Repetition of motivation structure (test set)	2001	47	24
Motivation expansion (training set)	3201	95	42

Motivation expansion (test set)	801	95	42
------------------------------------	-----	----	----

V. CASE STUDY

Since there is no previous research in this direction, the purpose of this experiment. Therefore, in this experiment, the difference between the predicted motivation sequence and the real motivation sequence is verified by the edit distance, and the validity of the experiment is calculated by calculating the ratio of the edit distance to the total number of notes. Its calculation formula is as follows:

$$Accuracy_{s,s'} = \frac{S_j - D_{[s,ss']}}{S_j} \tag{4}$$

$$D_{[s,s']} = \min \begin{cases} D[S'_{i-1}, S_j] + 1; \\ D[S'_i, S_{j-1}] + 1; \\ D[S'_{i-1}, S_{j-1}] + \begin{cases} 1; & \text{If } S_j \neq S'_i \\ 0; & \text{If } S_j = S'_i \end{cases} \end{cases}$$

In the first experiment, the accuracy of predicting 100 motivations was 25.6%. The experimental results were very unsatisfactory, and the reason was found later: because short sentences evolved based on motivation, three situations were summarized according to the different evolution methods: 1. Short sentences generated by repetition of motivation. 2. Through repetition of motivational structures, pitch changes produce short sentences. 3. Generate short sentences by expanding the motivation. In response to the above, the motivation dataset was classified and finally re-divided into three datasets. A ten-fold crossover experiment was performed on each dataset, and the ten results were averaged. The final experimental results are shown in Table 3.

Table 3: Basic parameter of final experimental results

Dataset type	Number of tests	Accuracy
Motivation repetition	100	95.7%
Repetition of motivation structure	100	91.7%
Motivation expansion	100	50.7%

The experimental results show that the teaching model has a high accuracy for the analysis of the teaching mode of college music composition theory courses, and its motivation repetition rate can even reach more than 95%. The common short sentences are mainly the repetition of motivation structure. Although the number of notes is relatively equal to the motive, it is also twice the magnitude, but because its pitch is raised or lowered, its musical structure may be different, the former section is dominant chord to dominant chord, and the latter section is dominant chord to subdominant chord. Therefore, it cannot be simply generalized. Models with repetitive motivational structures can be used to extract a large portion of motivations. This means that the model can be used for course teaching mode analysis. Based on this, the entire teaching model analysis process is shown in Figure 10.

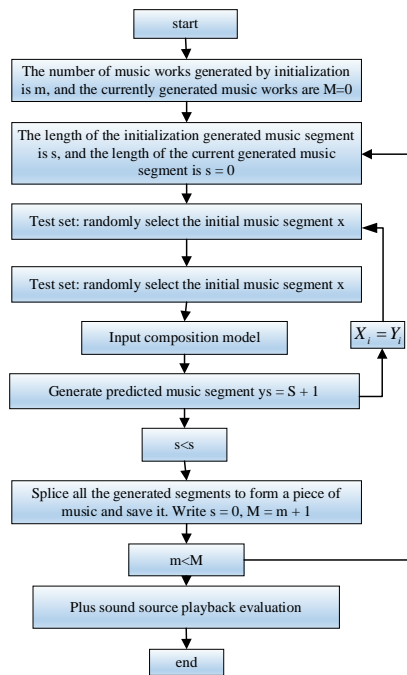

Fig.10 Teaching model analysis process

Figure 11, Figure 12, and Figure 13 are a section in the music score, which represents the syllable after the main melody extraction experiment, and the multi-tone overlapping phenomenon on each track is removed by the contour algorithm; it means that the average pitch is selected the highest track acts as the main melody track.



Fig. 11 Original score



Fig. 12 Score after removing polyphony



Fig. 13 Extracted main melody score

In theory, the more dimensions of the note feature vector, the more note context information is represented. Here, the dimension of the note feature vector to be generated is set to 129 for the follow-up and the automatic composition. The note of the binary note data was set to calculate the error; in the training process of the note feature vector, as figure 14 shown.

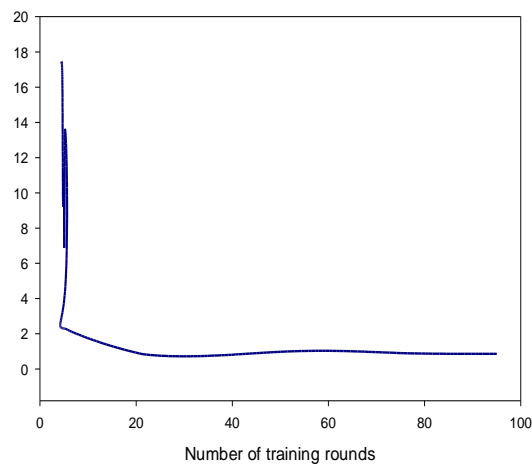

Fig. 14 Change curve of loss function

Then combine the requirements of modern music composition to make Students further clarify their learning goals, realize the inheritance of traditional composition culture, and make students' basic knowledge more solid.

The second is to try an information-based teaching model. Teaching reform needs to be explored in constant trials. Teachers need to play their practical role, devote themselves to teaching reform, have the courage to try a variety of teaching modes and combine theory with practice to quickly explore effective teaching modes. For example, students are encouraged to show their creative ideas in the classroom, and a cooperative learning mode is carried out. The teacher gives the composition direction. Students can freely cooperate and discuss in groups to stimulate student's creative inspiration, and the classroom atmosphere is naturally active. Another example is to guide students to use Internet devices to broaden their horizons, enrich students' educational resources, and change the current situation of the lack of teaching resources for music composition theory in ordinary colleges.

VI. CONCLUSION

Music composition creation is an important part of music discipline. It uses music to convey language information in life. It is one of the ways to inherit human art and culture. Music creation is diverse and rich and cannot be copied. Good music It can inspire people to work hard, and the progress of the times promotes the deepening reform of music teaching, and continuously improving the ability of music creation is a long-term problem for music workers in colleges. This research takes the MCC algorithm as the core and builds a teaching model fitting. Through experimental verification and loss function analysis, it demonstrates the importance of formulating clear teaching goals and trying an information-based teaching model. According to the shortcomings in the solution process, the algorithm is added to the local search algorithm to form a hybrid algorithm, which improves the accuracy of the model.

ACKNOWLEDGMENT

This work no funding supported.

REFERENCES

- [1] Cláudia Faria, Chagas, I. , & Cecília Galvo. (2022). Lesson-study on health education with pre-service biology teachers. *Journal of Education for Teaching*, 48(2), 214-227.
- [2] Mccarthy, B. , Herda, D. , & Hagan, J. . (2022). Racist torture and the code of silencea situational analysis of sidebar secrecy and legal cynicism in the trial of jon burge. *Du Bois Review: Social Science Research on Race*, 19(1), 31-60.

- [3] Currie, J. S. G. , & Clarke, B. . (2022). Fighting talk:the use of the conceptual metaphorclimate change is conflictin the uk houses of parliament, 2015–2019. *Journal of Language and Politics*, 21(4), 589-612.
- [4] Trauschke, M. . (2021). Diagnosing learning and teaching potentials - a cognitive linguistic analysis of conceptions of heart excitation. *GMS Zeitschrift für medizinische Ausbildung*, 38(2), 1-23.
- [5] She, R. , Chen, X. , Li, L. , Li, L. , Huang, Z. , & Lau, J. T. F. . (2022). Factors associated with behavioral intention of free and self-paid severe acute respiratory coronavirus virus 2 (sars-cov-2) vaccination based on the social cognitive theory among nurses and doctors in china. *Infection Control And Hospital Epidemiology*, 43(5), 609-615.
- [6] Suraj, S. R. S. , Padmaja, S. S. , Vishnu, S. , & Gupta, J. . (2022). Shades of institutional change: the case of nature fresh dairy development project. *The Journal of Agricultural Education and Extension*, 28(1), 3-20.
- [7] Medlin, D. L. , & Sills, R. B. . (2022). Semi-automated, object-based tomography of dislocation structures. *Microscopy and Microanalysis*, 28(3), 633-645.
- [8] Steer, A. L. . (2022). Mobilising freirean pedagogical practices in south africa and canada during facilitator training. *Studies in Continuing Education*, 44(1), 55-69.
- [9] Aigbavboa, C. , Aghimien, L. , Aghimien, D. , & Oke, A. . (2022). Latent institutional environment factors influencing construction digitalization in south africa. *International Journal of Construction Education and Research*, 18(2), 142-158.
- [10] Pesonen, H. V. , Tuononen, T. , Lahdelma, M. , & Fabri, M. . (2022). Autistic graduates: graduate capital and employability. *Journal of Education and Work*, 35(4), 374-389.
- [11] Hynes, K. , Anderson, S. , Xu, M. , Friedlander, M. L. , Tambling, R. , & Megale, A. , et al. (2022). Examining behavioral manifestations of split alliances in four couple therapy sessions. *Journal of Couple And Relationship Therapy*, 21(2), 81-104.
- [12] Min, K. , Mai, Q. , & Zhang, X. . (2022). Fast and separable estimation in high-dimensional tensor gaussian graphical models. *Journal of Computational and Graphical Statistics*, 31(1), 294-300.
- [13] A. P, A. Sharma, A. Singla, N. Sharma and D. G. V, "IoT Group Key Management using Incremental Gaussian Mixture Model," 2022 3rd International Conference on Electronics and Sustainable Communication Systems (ICESC), Coimbatore, India, 2022, pp. 469-474, doi: 10.1109/ICESC54411.2022.9885644.
- [14] Doyon-Martin, J. , & Gonzalez, A. . (2022). It brought life back to prison: content analysis of prison-based dog training programs in four midwestern prisons. *Contemporary Justice Review*, 25(1), 82-99.
- [15] Kandanaarachchi, S. , & Hyndman, R. J. . (2022). Leave-one-out kernel density estimates for outlier detection. *Journal of Computational and Graphical Statistics*, 31(2), 586-599.
- [16] Esmail, R. , Hanson, H. M. , Holroyd-Leduc, J. , Niven, D. J. , & Clement, F. M. . (2021). Pp100 characteristics to consider in a knowledge translation theory, model or framework for health technology reassessment. *International Journal of Technology Assessment in Health Care*, 37(S1), 18-19.
- [17] Aistleitner, M. , & Puehringer, S. . (2021). The trade (policy) discourse in top economics journals. *New Political Economy*, 26(5), 748-764.
- [18] Huang, R., Yang, X. and Ajay, P., 2023. Consensus mechanism for software-defined blockchain in internet of things. *Internet of Things and Cyber-Physical Systems*, 3, pp.52-60.
- [19] Wu, X. . (2022). Research on the reform of ideological and political teaching evaluation method of college english course based on "online and offline" teaching. *Journal of Higher Education Research*, 3(1), 87-90.

- [20] Nkengne, P. , Pieume, O. , Tsimpo, C. , Ezeugwu, G. , & Wodon, Q. . (2021). Teacher satisfaction and its determinants: analysis based on data from nigeria and uganda. *International Studies in Catholic Education*, 13(2), 190-208.
- [21] Manolopoulos, P. P. , Chatzidakis, S. , Vasilakou, A. , Balta, M. , & Ntourakis, D. . (2022). A standardized workshop for peer-teaching simple interrupted sutures to medical students: analysis of the student factors that affect outcomes. *Journal of Investigative Surgery*, 35(6), 1379-1384.
- [22] Murphy, R. , Ward, F. , McCabe, U. , Flannery, M. , Cleary, A. , & Hsu, H. P. , et al. (2022). Recasting embodied and relational teaching in the arts: teacher educators reflect on the potential of digital learning. *Irish Educational Studies*, 41(1), 213-224.
- [23] Liu, S. , & Wang, J. . (2020). Ice and snow talent training based on construction and analysis of artificial intelligence education informatization teaching model. *Journal of Intelligent and Fuzzy Systems*, 40(3), 1-11.
- [24] Dong, Q., & Liu, X. Optimization Practice of University Innovation and Entrepreneurship Education Based on the Perspective of OBE. *Journal of Combinatorial Mathematics and Combinatorial Computing*, 118, 181-189.
- [25] Liao, Q. English Teaching Project Quality Evaluation Based on Deep Decision-Making and Rule Association Analysis. *Journal of Combinatorial Mathematics and Combinatorial Computing*, 118, 119-127.