

**Investigation on Mitigation of Power Quality Problems in Utility and Customer side Using Unified Power Quality Conditioner**



The current harmonics, voltage unbalance, sag and swell conditions are the serious power quality problems (PQ) arising in a power distribution system. The impact of unified power quality conditioner for mitigation of power quality problems in utility and customer side is investigated in the paper. The topology of UPQC is configured from the two voltage source inverters connected back to back with a common DC link acting as a series and shunt active power filter. The DC link voltage is greatly perturbation by voltage unbalance in utility side and sudden load change in customer side. The hysteresis voltage and current controller of UPQC strategy are implemented with the aim to have the robust control on compensation voltage and compensation current generated by the series and shunt active filter respectively. An elaborative proposed strategy applied to practical issues is investigated in Matlab/Simulink simulation tool.

**Keywords:** Power Quality; Power Factor Improvement; Total Harmonic Distortion; UPQC; Series and Shunt Active Power Filter;

## 1. Introduction

The customers of the electricity board have been increasing in exponential way in the recent years. These customers used to demand the electricity board on delivering the power of much quality in nature. The quality of the power is reduced by the components of power transmission system namely transformers, electric motors, power electronic devices based electric loads etc [1-3]. The power quality problems have caused overheating, reduced life time, acoustic noise emission, pulsating torque in the electrical machines, malfunction of equipments and radio interference. These effects were a bit expensive for the customer, ranging from minor quality variations to production downtime. All this interest has resulted in a variety of devices have proposed to mitigate power disturbance like voltage and current harmonics, sags, swells, imbalance [4-6].

The custom power devices [7-9] provide an appropriate solution to compensate the power quality problems and also protect the load from voltage sags, swells, outages etc. The custom power device is classified on the basis of topology namely shunt active power filter, series active power filter and unified power quality conditioner strategy [10-13]. The unified power quality conditioner is the universal power conditioner for compensating power quality problems. The unified power quality conditioner strategy is the combination of series and shunt active power line conditioner with a common DC link capacitor.

The various types of control techniques used in UPQC strategies were listed in the survey. The unit vector template generation (UVTG) technique is simple to implement and

\* Corresponding author: A. Senthilkumar, Assistant Professor (Contract), Pondicherry Technological University, India Puducherry Email ID : [senthilkumar.a@pec.edu](mailto:senthilkumar.a@pec.edu).

<sup>2</sup> Muthaiammal Engineering College, India

<sup>3</sup> Annamalai University, Chidambaram, India

analysed in this paper. The UVTG technique utilizes a PI controller for regulating DC link voltage between series and shunt converter. In this paper, the UPQC strategy is designed to mitigate both grid side and load side disturbances [13-16].

A general introduction to the problem of power quality is presented here in introduction and a review of traditional strategies is traced, the need for UPQC strategy for obtaining improved power quality is discussed in section II, the control technique for generating reference voltage and current signal using PI is discussed in Section III, a mathematical approach to quantify the benefits of power quality is suggested in section IV, the simulation results for the compensation of power quality problems in utility and customer side are brought out in section V and the conclusions of this paper finds a place in section VI.

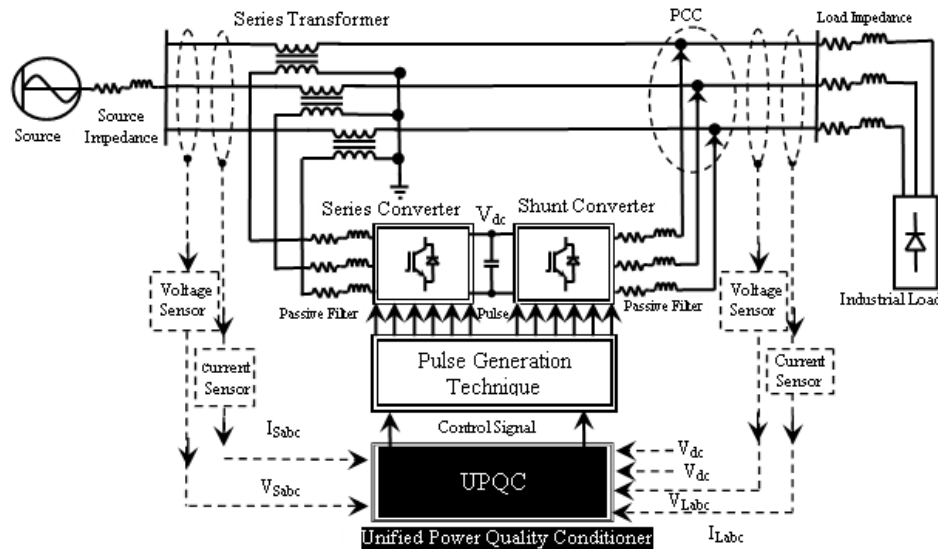

Fig.1. Construction of Unified Power Quality Conditioner Strategy

## 2. Unified Power Quality Conditioner

Power quality is obviously of great interest in the practical world of engineering. In recent years, for power quality management, many important decisions are made by describing the system under study as precisely and quantitatively as possible [2,10]. Hence power quality management has led to a variety of devices designed for mitigating power disturbance. Among several devices, UPQC strategy is a novel power device proposed to compensate for power disturbances in a distribution system. The configuration of a unified power quality conditioner strategy is highlighted in Fig.1. The UPQC strategy is compressed of back to back two voltage source inverter with a common DC link capacitor. In which one voltage source inverter is connected in series between source and load through series transformers which act as a series active power filter. Another voltage source inverter is

connected in parallel between source and load at the point of common coupling (PCC) and acts as a shunt active power filter. The series active power filter is employed to mitigate the voltage imperfections such voltage sag, swell, harmonics, notches etc. The shunt active power filter is designed to mitigate the current imperfections such as current harmonic distortions, power factor correction and reactive power compensation. Such that the UPQC strategy is acting as an electronic isolator between source and load because by which prevented the power quality problems on both grid and load sides were eliminated. The following section deals with control technique for UPQC [5,15].

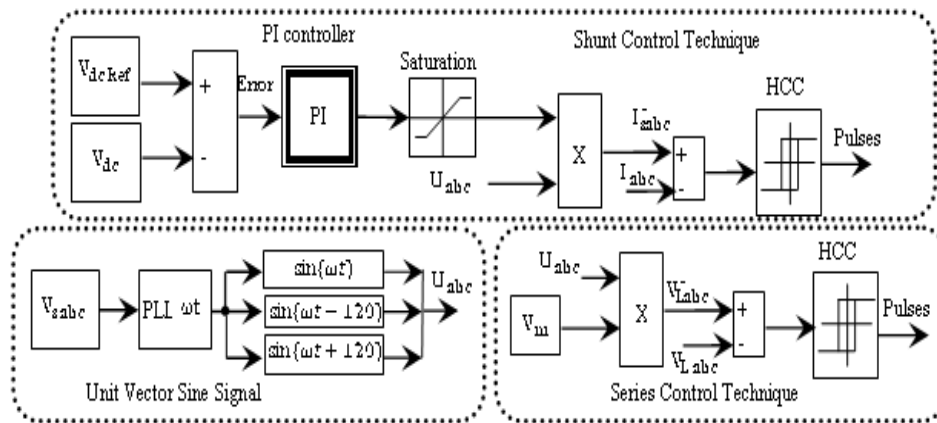

Fig 2. Block Diagram for Unit Vector Template Generation technique

### 3. Unit Vector Generation Technique

The control technique of the UPQC strategy is deployed to generate reference signal is shown in the Fig.2. The reference signal is used to control inverter and compensates the power quality problems. The unit vector template generation technique (UVGT) is modeled as the series and shunt control technique of UPQC strategy. Moreover the shunt control technique is modeled to mitigate the current imperfections and the series control technique is employed to compensate the voltage related power quality problems. The magnitude of the reference current signal is extracted from the difference of reference and actual DC link voltage by using PI controller. The reference current signal is generated from the product of estimated magnitude and unit sine vector signal. The pulses for shunt inverter were generated from the difference of reference and actual source current by using through hysteresis current controller. The reference voltage signal for series control technique is obtained from the product of rated load voltage magnitude and unit sine vector signal. The pulses for series active power filter were generated from the difference of reference voltage signal and load voltage. The power quality problems obtained in the system are represented as the pulses. These pulses are feed to the series and shunt inverters in opposite direction.

The signals are injected by series and shunt inverter cancel the power quality problems of the system. The following section deals with mathematical analysis [10,12].

#### 4. Mathematical Modeling of the Control Technique

The three phase source voltage of the system is given as follows

$$V_{sa}(t) = V_m \sin(\omega t) \tag{1}$$

$$V_{sb}(t) = V_m \sin(\omega t + 120^\circ) \tag{2}$$

$$V_{sc}(t) = V_m \sin(\omega t - 120^\circ) \tag{3}$$

Before compensation, the source voltage and current is equal to the load voltage and current. The non linear loads create harmonic components in the distribution system such that the source voltage and current contains both the fundamental and the harmonic current component is given as follows.

$$I_s(t) = I_L(t) \text{ and } V_s(t) = V_L(t) \tag{4}$$

$$V_s(t) = V_1 \sin(\omega t) + \sum_{n=1,3}^{\infty} V_n \sin(n\omega t) \text{ and } I_s(t) = I_1 \sin(\omega t + \phi_1^O) + \sum_{n=1,3}^{\infty} I_n \sin(n\omega t + \phi_n^O) \tag{5}$$

$$V_1 \sin(\omega t) \text{ and } I_1 \sin(\omega t + \phi_1^O) = \text{fundamental component} \tag{6}$$

$$\sum_{n=1,3}^{\infty} V_n \sin(n\omega t) \text{ and } \sum_{n=1,3}^{\infty} I_n \sin(n\omega t + \phi_n^O) = \text{harmonics component} \tag{7}$$

The power quality problems are created by these harmonics components in the distribution system. The UPQC strategy is designed to mitigate these power problems of the system. The reference voltage and current signal of the control technique is derived from this harmonic component. The inverters of UPQC strategy inject the detected harmonics in the opposite direction and cancel the harmonics and other power quality problems [1,5,16].

##### 4.1 Modeling of reference current signal generation for shunt active power filter

The reference signal for shunt converter is derived from the DC link Voltage. The DC link voltage is regulated by the shunt active power filter of UPQC strategy. The magnitude of reference current signal is estimated from the DC voltage error by using PI controller. The generation of reference current signal is given as follows

Reference signal = DC voltage Error\* controller\*Unit Sine signal

$$I_{sref}(t) = (V_{dcref} - V_{dc}) * (K_p + \frac{K_I}{s}) * \sin(\omega t) \quad (8)$$

where

$(K_p + \frac{K_I}{s})$  is PI Controller,  $(V_{dcref} - V_{dc})$  is error and  $\sin(\omega t)$  is unit vector

The reference signal for three phase signal Is obtained as following equations

$$I_{sref\_a}(t) = (K_p + \frac{K_I}{s}) * (V_{dcref} - V_{dc}) * \sin(\omega t) \quad (9)$$

$$I_{sref\_b}(t) = (K_p + \frac{K_I}{s}) * (V_{dcref} - V_{dc}) * \sin(\omega t + 120^\circ) \quad (10)$$

$$I_{sref\_c}(t) = (K_p + \frac{K_I}{s}) * (V_{dcref} - V_{dc}) * \sin(\omega t - 120^\circ) \quad (11)$$

After connecting shunt active power filter, the source current of the nonlinear system is derived as

$$I_s(t) = I_{sh}(t) + I_l(t) \quad (12).$$

The compensating current is equal to the harmonic content present in the system. The shunt active filter topology injects the compensation current in the opposite direction at PCC. After injecting the compensation current, the source current is found to be

$$I_{sh}(t) = -I_h(t) = -\sum_{n=1,3}^{\infty} I_n \sin(n\omega t + \phi_n^o) \quad (13)$$

After injecting the compensating current, the source current is observed to be

$$I_s(t) = -\sum_{n=1,3}^{\infty} I_n \sin(n\omega t + \phi_n^o) + I_l(t) \quad (14)$$

$$I_s(t) = -\sum_{n=1,3}^{\infty} I_n \sin(n\omega t + \phi_n^o) + I_1 \sin(\omega t + \phi_1^o) + \sum_{n=1,3}^{\infty} I_n \sin(n\omega t + \phi_n^o) \quad (15)$$

$$I_s(t) = I_1 \sin(\omega t + \phi_1^o) \quad (16)$$

After mitigating harmonics, the voltage and current observed to be in phase with each other. Such that the angle between voltage and current is zero and the source current is given as

$$I_s(t) = I_1 \sin(\omega t) \quad (17)$$

#### 4.2 Modeling of reference voltage signal for series active power filter

The reference voltage signal for series active power filter is generated from the product of rated load voltage magnitude and unit sine signal is given as follows

Reference voltage signal = Rated load magnitude\* Unit Sine signal

$$V_{ref\_a}(t) = V_m * \sin(\omega t) \tag{18}$$

$$V_{ref\_b}(t) = V_m * \sin(\omega t + 120^\circ) \tag{19}$$

$$V_{ref\_c}(t) = V_m * \sin(\omega t - 120^\circ) \tag{20}$$

The error signal is computed from difference of reference load voltage and actual load voltage. The pulses for series active power filter were obtained from the error signal through hysteresis voltage controller.

After feeding pulses, the series active power filter strategy starts to inject the compensate voltage.

$$V_s(t) = V_L(t) + V_{sr}(t) \tag{21}$$

#### 4.3 Mathematical analysis on sag condition for without and with UPQC strategy

Case1: Without UPQC strategy

Normally the source voltage is equal to the load voltage; the 20% of source voltage is reduced means the load voltage has also reduced to 20% of rated voltage. In this case, the performance of the load has also been disturbed and sometimes it might damage the load.

$$V_s(t) = V_L(t), \text{ if } V_s(t) = 0.8V \text{ means } V_L(t) = 0.8V$$

Case II: With UPQC strategy

After connecting UPQC strategy, the source voltage is found to be the sum of load voltage and compensating voltage. The source voltage is assumed to reduce to 20% of its rated voltage thereby the series active power filter inject the compensating voltage to 20% of rated voltage, the source voltage would be

$$V_s(t) = V_L(t) + V_{sr}(t) \text{ if } V_s(t) = 0.8V \text{ means } V_{sr}(t) = 0.2V \text{ and } V_L(t) = V$$

The series active power filter of UPQC strategy helps to maintain the load voltage at rated load voltage with irrespective to changes of the source voltage.

#### 5. Simulation Results and Discussion

The paper investigates the behavior of UPQC strategy for the management of inherent issues of power system. The effective compensation of power quality problems by using UPQC strategy is performed in Matlab/Simulink simulation tool software. The voltage and current profile of the grid and load are analyzed for following operating conditions, such as

voltage sag, unbalanced voltage on the source side and unbalanced load conditions. The system ratings are taken for investigation are  $230\sqrt{3/2}$  line to line RMS voltage, three phase RL load is  $5KW+j0.1KVAR$ , three phase rectifier load is 20ohms and 20mH, single phase rectifier load is 60ohms and DC link voltage is maintained at 600V.

### 5.1 Simulation analysis for compensation of voltage sag in source side using UPQC strategy

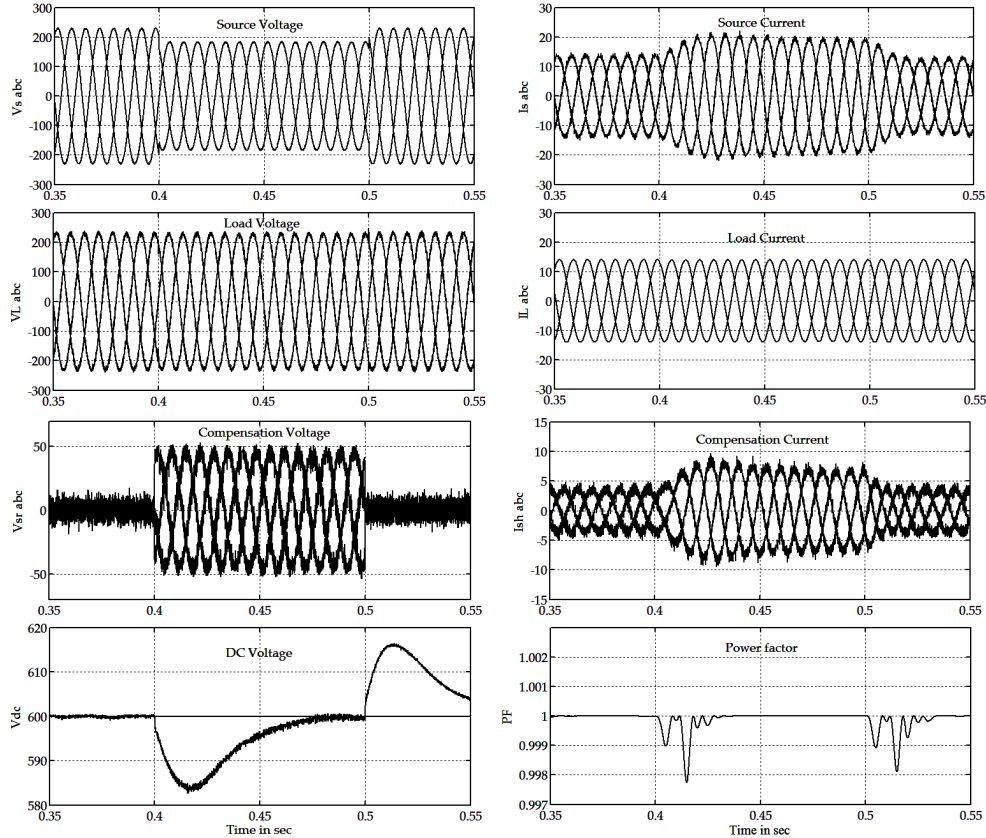

Fig.3. Simulation Results for compensation of voltage sag in source side using UPQC

The compensation of voltage sags conditions using UPQC strategy is illustrated in the Fig. 3. In this investigation, at 0.4 sec the grid voltage is assumed to be reduced to 20% of its rated voltage. At the instant of 0.4 sec, the series active power filter of UPQC strategy has started to inject the required voltage for maintaining the load voltage at rated value. After compensated, the load voltage is maintained at rated voltage with the help of series active power filter. Corresponding DC link voltage is also represented in the Fig.3. In normal operating condition, the DC link voltage is maintained at rated value. After occurring sag conditions on the source side, the DC link voltage has begun to reduce. The shunt active power filter has started to inject the compensation current which helps to regulate the DC link voltage at rated value. The load current has not found to be disturbed by the support of

shunt active power filter during voltage sag condition. An interesting point to observe, the power factor of the system is maintained in unity during normal operating condition and voltage sag conditions. This demonstration ensured that the UPQC strategy has capable of compensating voltage sags and maintain the load voltage at rated value. analyzes are given in table 1 and compensation of swell is given in table 2.

**5.2 Simulation analysis for compensation of voltage unbalance in source side using UPQC strategy**

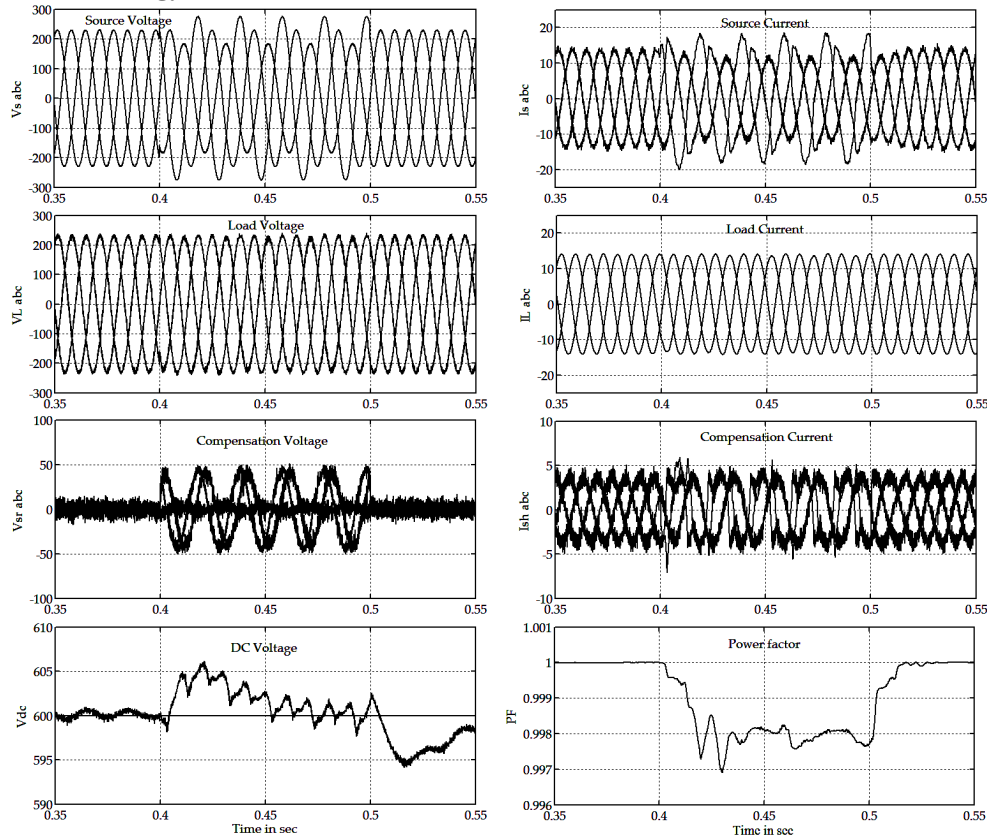

Fig.4. Simulation Results for compensation of voltage unbalance in source side using UPQC

The voltage and current profile for mitigation of voltage unbalance conditions is highlighted in the Fig4. For this investigation, the source voltage of three phases is forced to be unbalanced at 0.4 sec, phase A voltage is kept at rated source voltage, for phase B voltage is assumed to be reduced to 20% of its rated voltage and Phase C voltage is forced to be increased to 20% of its rated voltage. The series active power filter of UPQC strategy has detected source voltage unbalance and produced the compensation voltage is highlighted in the Fig.4. After compensated, the load voltage profile is forced to maintain at rated voltage irrespective to the source voltage unbalance by series active power filter. The source current is shown in the Fig.4. The load current is maintained at rated value by the



help of shunt active power filter shown in the Fig.4. And also the shunt active power filter supported to maintain the power factor near to the unity under voltage imbalance condition. This investigation proves that the voltage imbalance power quality problem has been mitigated by the UPQC strategy and maintained the load voltage at rated voltage and analyzes are given in table 3

### 5.3 Simulation analysis for compensation of load unbalance on source side using UPQC strategy

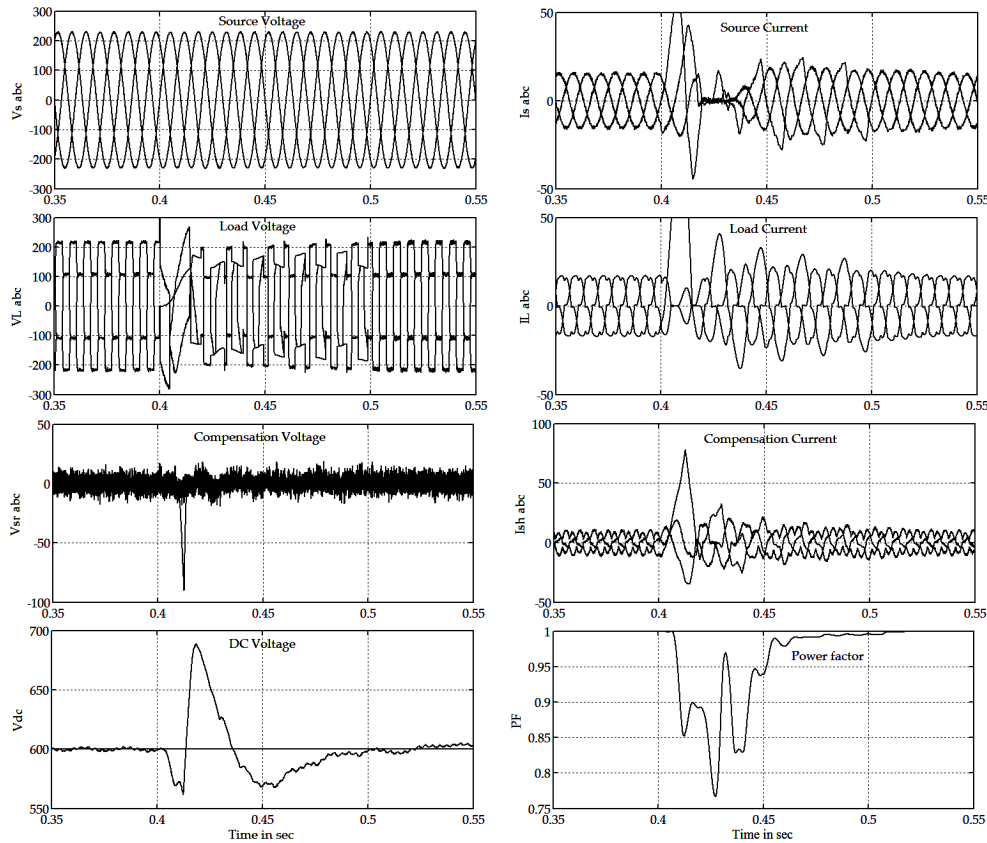

Fig.5. Simulation Results for compensation of load unbalance using UPQC

The simulation results for compensation of load unbalance problems are shown in Fig 5. The three phase rectifier RL load is connected on the load side by which the 25 % of THD are forced to generate on the load voltage and current. The single phase rectifier RL load is connected to load side between 0.4 to 0.5 sec such the system is formed to be distorted and unbalanced. In this mode of operation, the UPQC behaves as an active power filter. The series active power filter has detected the harmonics and voltage unbalance on load voltage and injected the compensation voltage in the opposite direction is shown in Fig.5. The source voltage is forced to maintain at rated magnitude and sinusoidal voltage by the series

active filter highlighted in the Fig.5. The load current is forced to be distorted and unbalance. The compensation current generated by the shunt active power filter is made the source current with minimum harmonic distortion is shown in the Fig.5. After compensation, the THD of source voltage and current is minimized to 1% and 3.9% respectively. The DC link voltage is regulated at rated value and power factor is maintained near to unity. The analysis has ensured that the UPQC strategy has overcome the load unbalance problems and analyzes are given in table 4. The compensation of harmonic distortion is given in table 5.

Table 1 Compensation of Sag Condition

Phase	Source Side Voltage (V)	Customer Side Voltage (V)
A	180	230.1
B	179	229.6
C	181	230.2

Table 2 Compensation of Swell Condition

Phase	Source Side Voltage (V)	Customer Side Voltage (V)
A	260.5	230.5
B	261.3	230.4
C	262.1	230.78

Table 3 Compensation of unbalanced load

Phase	Source Side Current (A)	Customer Side Current (A)
A	12.3	15.5
B	12.5	12.4
C	12.1	10.2

Table 4 Compensation of unbalanced Source

Phase	Source Side Voltage (V)	Customer Side Voltage (V)
A	245	230.6
B	230.5	229.9
C	200.7	230.1

Table 5 Compensation of harmonic distortion

Phase	Source Side Current THD (%)	Customer Side Current THD (%)
A	4.3	30.1
B	3.98	31.2
C	4.2	29.7

## 6. Conclusion

An UPQC topology for mitigating power quality distortions has been investigated in this paper. The control strategy generating the reference signal for balancing voltage and current profile under unbalanced source voltage and load conditions were discussed. The harmonics created by the nonlinear loads have been mitigated by the UPQC strategy. The

obtained results demonstrate that the proposed UPQC strategy has better capability to compensate the power quality problems rendered in the distribution system

## Appendix

### System Parameter

Source	Voltage and frequency	230V and 50Hz	
	Impedance	R=0.1Ω and L=0.1mH	
DC Link	Voltage	Conventional Topology	550V
		Proposed Topology	260V
	Capacitor	30000μF	
Shunt Active Power Filter	Impedance	R=0.001Ω and L=15mH	
Series Active Power Filter	Transformer	1KVA and 1:1	
	Impedance	R=0.001Ω and L=10mH	
Load	Impedance	R=0.001Ω and L=15mH	
	RL Load	5KW and 1KVAR	

## References

- [1]. H. Akagi, New trends in active filters for power conditioning, *IEEE Trans. Ind. Appl.*, 32( 6), 1312–1322, 1996
- [2]. R. M. Abdalaal and C. N. M. Ho, "System Modeling and Stability Analysis of Single-Phase Transformer less UPQC Integrated Input Grid Voltage Regulation," in *IEEE Journal of Emerging and Selected Topics in Industrial Electronics*, vol. 3, no. 3, pp. 670-682, July 2022
- [3]. H. Fujita and H. Akagi, The unified power quality conditioner: The integration of series and shunt-active filters, *IEEE Trans. Power Electron.*, 13(1), 315–322, 1998.
- [4]. V. Khadkikar, A. Chandra, A. O. Barry, and T. D. Nguyen, Application of UPQC to protect a sensitive load on a polluted distribution network, *Proc. IEEE PES General Meeting*, Montreal, QC, Canada, 2006.
- [5]. V. Khadkikar, A. Chandra, A. O. Barry, and T. D. Nguyen, Conceptual analysis of unified power quality conditioner (UPQC), in *Proc. IEEE ISIE*, 1088–1093, 2006.
- [6]. L. Meng et al., "Control Strategy of Single-Phase UPQC for Suppressing the Influences of Low-Frequency DC-Link Voltage Ripple," in *IEEE Transactions on Power Electronics*, vol. 37, no. 2, pp. 2113-2124, Feb. 2022
- [7]. P. Ray, P. K. Ray and S. K. Dash, "Power Quality Enhancement and Power Flow Analysis of a PV Integrated UPQC System in a Distribution Network," in *IEEE Transactions on Industry Applications*, vol. 58, no. 1, pp. 201-211, Jan.-Feb. 2022.
- [8]. M. Basu, S. P. Das, and G. K. Dubey, Comparative evaluation of two models of UPQC for suitable interface to enhance power quality, *Elect. Power Syst. Res.*, 821–830, 2007.
- [9]. K. Jindal, A. Ghosh, and A. Joshi, Interline unified power quality conditioner, *IEEE Trans. Power Del.*, 22 (1), 364–372, 2007.

- [10]. Karuppanan P and Kamala kanta Mahapatra, PID with PLL Synchronization controlled Shunt APLC under Non-sinusoidal and Unbalanced conditions, *National Power Electronics Conference (NPEC) Proceedings*, IIT-Roorkee, 2010.
- [11]. S. Devassy and B. Singh, Design and Performance Analysis of Three-Phase Solar PV Integrated UPQC, *IEEE Transactions on Industry Applications*, 54(1), 73-81, 2018.
- [12]. J. Ye, H. B. Gooi and F. Wu, Optimal Design and Control Implementation of UPQC Based on Variable Phase Angle Control Method, in *IEEE Transactions on Industrial Informatics*, 14(7), 3109-3123, 2018.
- [13]. S. Lakshmi and S. Ganguly, Modelling and allocation of open-UPQC-integrated PV generation system to improve the energy efficiency and power quality of radial distribution networks, *IET Renewable Power Generation*, 12(5), 605-613, 2018.
- [14]. J. Ye, H. B. Gooi and F. Wu, Optimization of the Size of UPQC System Based on Data-Driven Control Design, *IEEE Transactions on Smart Grid*, 9(4), 2999-3008, 2018.
- [15]. S. Devassy and B. Singh, Control of solar photovoltaic integrated UPQC operating in polluted utility conditions, *IET Power Electronics*, 10(12), 1413-1421, 2017.
- [16]. S. Devassy and B. Singh, Modifiedpq-Theory-Based Control of Solar-PV-Integrated UPQC-S, *IEEE Transactions on Industry Applications*, 53(5) 5031-5040, 2017.

© 2022. This work is published under  
<https://creativecommons.org/licenses/by/4.0/legalcode>(the“License”).  
Notwithstanding the ProQuest Terms and Conditions, you may use this  
content in accordance with the terms of the License.