

¹Narendran S P,
¹Janani R,
¹S. Balamurugan,
¹Janarthanan N*,
¹Chandra Dev K
A,
¹Dasi Raghuram¹

IoT Based Smart Kitchen Using Fuzzy Intelligence and Signal Processing



Abstract: Kitchen management remains a challenging task, despite many technological advancements. As a result, it's clearly time for us to get the kitchen work done with ease. The ingenious Kitchen uses the Internet of Things for design and features a mobile application as a user interface. Smart Kitchen includes a grocery management system, a fuzzy system for adaptive cooking and signal processing for identifying the cooker whistle. In the grocery management system, an ultra-sonic sensor measures the inventory level and using a Wi-Fi module, data updates the value of a particular key in the cloud. Users can see the amount of item left, be notified of shortage, and get the shopping list using the mobile application.

Keywords: Firebase Cloud, Fuzzy System, Hardware in Loop, IoT, MATLAB, Mobile Application, Signal Processing, Smart Kitchen.

I. INRODUCTION

The Internet of Things (IoT) is making possible a new wave of smart kitchen gadgets using sensors that can make our kitchens remotely accessible. The Internet of Things (IoT) turns ordinary objects into smart ones by modifying their underlying technology. From showing you the inventory levels on the mobile application to using adaptive cooking techniques, this technology ensures comfortable and safer use of the kitchen. K. Sakthisudhan et al. used an ultrasonic sensor to detect the current quantity of objects in each vessel and alert the consumer through a mobile app when an item fell below a predefined threshold level [1]. M. Gopi Perumal et al. used a gas sensor to detect a gas leak [2]. When the sensor detects a gas leak, it sends a high pulse to the Microcontroller. The microcontroller connects to the IoT Cloud and notifies the user. Asmita Varma et al., used IoT to sense the seepage in the gas cylinder and give information to the user via call, text message and email [3]–[5]. In their paper, Lei Lei Hnin et al. suggested using fuzzy logic to regulate the temperature in an induction furnace by taking user feedback (amount of meat, amount of water, and cooking time) and S. Jayapoorani et al., devised a plan to completely automate the wet grinder for grinding rice. The design of the system and timer is done [6]–[9]. M. Gopi Perumal et al., used a sound sensor to detect the number of whistles from a pressure cooker and notify the user to turn it off. Pranab Kumar Dhar et al., explains the filter which is audio signal processing and the differences between analog and digital filters [2], [10], [11]. The electricity tariff is decided locally using a smart meter which will decide the amount based on change in frequency and demand is explained in Balamurugan et al's, paper [12]. After looking into the existing technologies, the expiry date management system is absent. The induction stoves with whistle identification are available, but they have a limitation as the system counts any heavy noise in the kitchen as a whistle. Precise time set in wet grinders and temperature set in induction stove based on the type and quantity of an item is absent. A Smart induction stove has a whistle counting mechanism (with some constraints) is present in the market, but this induction stove does not have precise temperature control. This paper aims to bring every system (Inventory Management, Expiry Date Management and Kitchen safety) into the mobile application. A fuzzy system determines the temperature set value for the induction stove and time and water set values for the wet grinder. Signal processing techniques (Frequency Analysis and Filter Design) identifies and counts the pressure cooker whistle from the surrounding noise. This paper is divided into sections, each dealing with specific topics of our work. Section II describes the system model. This chapter also includes a brief explanation of the features. Section III deals with fuzzy intelligence for adaptive cooking on a wet grinder and induction stove using MATLAB. Section IV discusses the mobile application development using MIT App Inventor has Inventory Management, Expiry Date

management and kitchen safety. Signal Processing for Cooker Whistle Identification includes extracting samples, designing a filter and whistle counter is explained in Section V. Hardware implementation is explained in Section VI, includes implementing intelligent systems in Arduino and IoT hardware.

II. NOTATION

The notation used throughout the paper is stated below.

Indexes:

- $\mu(x_i)$ is the membership value for point
- X_i in the universe of discourse

III. SYSTEM MODEL FOR IOT BASED SMART KITCHEN USING FUZZY INTELLIGENCE AND SIGNAL PROCESSING

3.1. Objective function

The system model for the proposed kitchen management is divided into three parts. The first system employs an adaptive cooking technique that uses the fuzzy logic system for induction stove, Time and wet grinder. The second system is Signal processing for cooker whistle identification and counting. The final system includes the Grocery Management system which uses IoT for and the Mobile application for operations such as Inventory Level Monitoring, Expiry date management, Shopping list creation and kitchen safety notifications. It is depicted in Figure 1.

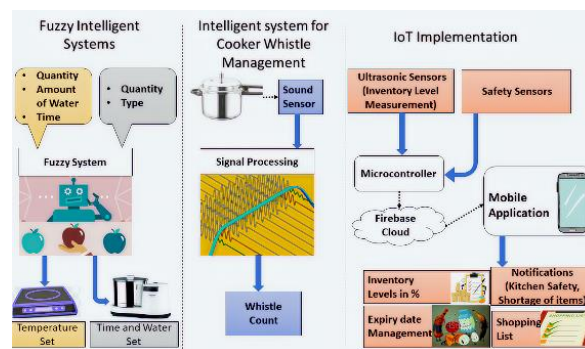

Figure 1 System Model for Smart Kitchen Management using Intelligent Systems and IoT.

The system model is explained in Figure 1. In the Fuzzy intelligent systems, the input to the induction stove and wet grinder is obtained from the user. The data obtained is processed using Fuzzy Logic and the output is either temperature or time set. For the IoT Implementation, the ultrasonic sensor employed will provide the levels of inventory referencing Sakthisudan's[1] work and transfer the data from the sensor to Firebase Cloud. The mobile application fetches data from the cloud and performs the notification operation if they go below the threshold levels. The users will be notified via the app regarding the expiry date. If there is any gas leakage, user will be notified and the trip signal is given to the breaker circuit referencing Gopi Perumal's work [2]. Finally, the signal processing techniques are employed to count the number of whistles is done in the intelligent system for cooker whistle management.

IV. FUZZY INTELLIGENCE FOR ADAPTIVE COOKING

Fuzzy logic provides the quantity, water and time-based temperature set for the induction stove and type and quantity-based water and time set for the wet grinders. The input membership functions are mapped to the output membership functions by a set of rules formed based on the data from the internet sources and the experience of the experts in that field. Implementation is done using the fuzzy logic toolbox available in MATLAB [13](Mamdani approach).

4.1 Temperature Set in Induction Stove

In the induction stove, the types of the item to be cooked include milk, rice, meat and vegetables. The inputs from the user for the type of milk include the amount of milk(ml) and the time in which the milk is to be boiled. For the types - rice, meat and vegetables, the inputs include the quantity of item(grams), amount of water(ml) and the time (minutes) for which item needs to be cooked. In type rice, the input ranges up to 1 Kilograms and the water ranges up to 2L and time range from 10 to 60 minutes. Output ranges from 393 K to 473 K. These are divided into three linguistic variables namely, Low, Medium, High. The membership function is designed based on the linguistic variables for the type rice. The triangular membership function is chosen for Medium and the Trapezoidal Function is chosen for Low and High. The membership functions for the remaining inputs follow the same pattern. The rules for cooking rice on an induction stove are created based on the expertise collected from professionals and is tabulated in Table 1.

When rice of high quantity with high amount of water needs to be cooked in low time range the temperature range should be High is one of the rules formulated and shown in Table 1. Defuzzification is done using centroid method given in Eq.(1).

$$x_{Centroid} = \frac{(\sum_j \mu(x_j)x_j)}{(\sum_j \mu(x_j))} \tag{1}$$

where $\mu(x_i)$ is the membership value for point and x_i in the universe of discourse.

Table 1 Rules Table for Cooking Rice.

Quantity (grams)	Amount of Water (ml)	Time(mins)	Temperature (°C)
Low	Low	Low	Low
Low	Low	Medium	Low
Low	Low	High	Low
Medium	Medium	Low	High
Medium	Medium	Medium	Medium
Medium	Medium	High	Low
High	High	Low	High
High	High	Medium	High
High	High	High	Medium

If the quantity of rice to be cooked is 200 grams and Amount of water used for cooking is 400 millilitres and the time to cook the rice is 3 minutes is given to the Fuzzy Logic controller as input, the temperature set for the Induction Stove is obtained as 156°C.

4.2 Time Set for Wet Grinder

In the fuzzy system for wet grinder, the inputs include the type (Urad dhal or rice) and the quantity(grams). The output time and water sets are given based on the type of the item and its corresponding amount. For a wet grinder, the input quantity goes up to 2Kilograms and are divided into five Linguistic variables namely, V.Low, Low, Medium, High and V.High. The type is either Urad or Rice. The output time ranges from 20-60 minutes and the amount of water ranges from 0.2-0.8 L. Output is divided into three linguistic variables namely, Low, Medium, High. For the input quantity, the triangular membership function is chosen for Low, Medium and High and Trapezoidal Function is chosen for V.Low and V.High. For Input type, the Trapezoidal Function is chosen for Urad and Rice. For output, the triangular membership function is chosen for Medium and Trapezoidal Function is chosen for Low and High. The other output also follows the same membership function. The rules for the fuzzy in Wet grinder are formulated based on the knowledge gained and is tabulated in the Table 2.

Table 2 Rules Table for Fuzzy in Wet Grinder.

Quantity	Urad		Rice	
	Time (minutes)	Amount of water (ml)	Time (minutes)	Amount of water (ml)

V.Low	Medium	Low	Low	Low
Low	High	Medium	Low	Medium
Medium	-	-	Medium	Medium
High	-	-	Medium	High
V.High	-	-	High	High

For wet grinder if the rice with high quantity is given then the time should be in medium range and amount of water to be given will be high is one of the rules formulated and shown in Table 2. The defuzzification method used here is centroid method which is explained in Eq.(1).

If the input quantity to grind in the wet grinder is 0.5 kilograms and the type of the item is Urad dhal then the amount of water is 0.475 L and time is 44.7 minutes is obtained as output.

V. IOT AND MOBILE APP FOR GROCERY MANAGEMENT

As a part of IoT, a mobile application that has access to the cloud is developed. The mobile application developed can be used to create alerts to users and give information from the kitchen. The platform used for developing the mobile application is the MIT App Inventor. The cloud using which we store and retrieve the value is Firebase. This mobile application has three main features are Inventory Management, Shopping list creation and Expiry Date Management. It also looks upon giving notifications to the user regarding kitchen safety. When the user enters the item name, the percentage of item is displayed in suitable color and notified if the amount of item is less than 30% in the container. In expiry date management, the user will be notified 10 days before the date of expiry or on the date of expiry and will perform tasks accordingly.

5.1 Inventory Management

When the user enters the item name, the percentage of that item is displayed (the corresponding data is being retrieved from the cloud) in suitable colour (red if the item is below 30%, yellow if the item is between 30% to 60%, else green) and notifies the user of any shortage in the item (less than 30%). The level of the container will be fed from the sensor which is placed in the container. The notification will be given to the user when there is a change in the database value for that item.

5.2 Shopping List Preparation

If user requests for shopping list, the tag list from the real time database will be called and stored in a list locally. Then, the values for each tag will be retrieved (in percentage) and converted into kilogram with the information available. So, the amount of item to be purchased will be displayed corresponding to the name of the item. The amount of item is calculated using the formula in Eq.(2).

$$\text{Amount to buy} = [\text{Maximum amount} - \{(\% \text{ present}) * \text{Maximum amount}\}] \quad (2)$$

Where, the amount to buy, maximum amount is represented in kg. Maximum amount is the maximum kilogram of item that the container can hold. It is calculated by using volume formulae in Eq.3 and Eq.4.

$$\text{Volume} = \text{Length} * \text{Breadth} * \text{Height} \quad (3)$$

$$\text{Density} = \frac{\text{Mass (in kg)}}{\text{Volume (in m}^3\text{)}} \quad (4)$$

From Eq.(3) and Eq.(4) we can find the maximum mass that a container can contain by knowing the density of the item and the volume of the container. The shopping list will make user to buy only required items and there will be less food wastage, which is now a huge global problem.

5.3 Expiry Date Management

The item and the number of days left for expiry are obtained as an input from the user and are stored in a list in the local database of the app. When the application is opened again, the item is again retrieved from the database. The corresponding date on which the item is entered is noted and is stored in a list with item name as a tag. The number of days left for expiry is then added to this list which contains corresponding date and the expiry date is predicted. The clock timer will call the prediction function. The date is predicted by using this formula Eq.(5):

$$\text{Entered number of days} + \text{present date} + \text{present month} * 30. \quad (5)$$

The Eq.(5) will predict a date of expiry and the prediction function will calculate the number of days using

$$\text{current date} + \text{current month} * 30 \quad (6)$$

This function will check the date once a day whether the difference between the predicted date calculated using Eq.(5) and today's date calculated using Eq.(6) is 10 or zero. If it is ten, the user will be notified. If zero, the user is notified and item is deleted from the list.

VI. SIGNAL PROCESSING FOR COOKER WHISTLE IDENTIFICATION

A system that can distinguish between a noise and a cooker whistle is developed using MATLAB Simulink. It increments the count only if the signal that is being read is a cooker whistle. This is achieved by passing the signal into a bandpass filter that is designed appropriately. In order to identify the pressure cooker sound from the surrounding noise and to keep track of it, Acquiring Audio Samples followed by frequency analysis of collected samples. Based on the analysis, filter is designed. Based on the filtered output signal, whistle is counted if present.

6.1 Acquiring Audio Samples

The input audio file is read by 'From Multimedia' block in the Simulink. For the uniformity in samples and to maintain the accuracy of the system when deployed to hardware, the following steps are taken care while recording the whistle samples. Cell phone is placed 15 cm from the whistle and Microphone facing the Pressure cooker. The whistle recordings of pressure cookers of different brands with different capacities cooking different items are collected. Also, possible noises that can occur in a kitchen environment like frying, mixer grinder recordings are also collected.

6.2 Frequency Analysis of Collected Samples

In order to find the frequency of the collected samples, the signals are viewed in the spectrum analyser. Using the peak finder, the frequency content with the maximum magnitude is found and noted. The following Figure 2 shows the frequency spectrum of a collected sample of cooker whistle.

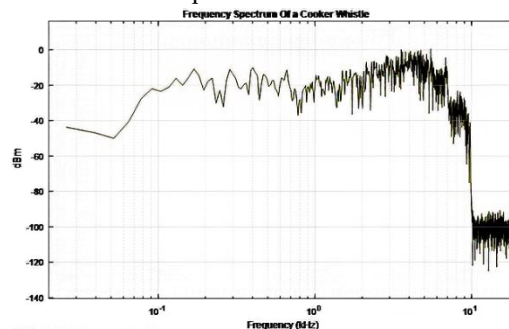

Figure 2 Spectrum of a Cooker Whistle Audio Sample.

Figure 2 shows the spectrum of a cooker whistle sample and the peak finder in the spectrum analyser showing the peak magnitude and its corresponding frequency. After analysing the collected whistle samples and noise

samples, the frequency range of cooker whistle falls in the range between 5kHz to 6kHz and the frequency range of noise signals fall in the range below 4 kHz except frying sound, one of the most frequently occurring noise in the kitchen has frequency of about 12 kHz.

6.3 Development and Design of Bandpass Filter

Based on the inference from the frequency analysis, a bandpass filter that allows the signals with frequencies between 5 and 6 kHz suits the purpose. The designed filter Band-pass filter is an Infinite Impulse Response (Chebyshev) filter with Passband of 5 to 6 kHz with cut off frequencies 4.75 and 6.25 kHz and it has stopband attenuation of 80 dB. The structure of filter is Direct-form II SOS. By using the information above, a filter is designed which has frequency response as in Figure 3.

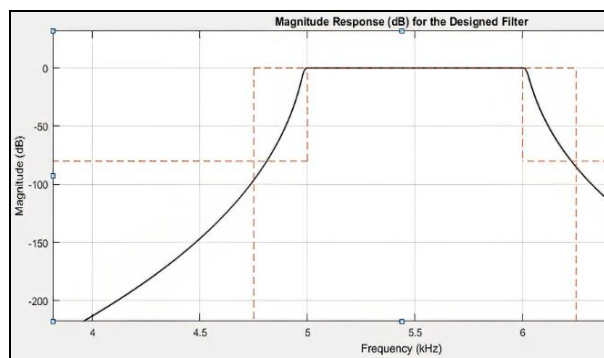

Figure 3 Magnitude Response for the Designed Cooker Whistle Identification Filter.

Figure 3 shows the designed filter's magnitude response. The designed filter is then implemented and the cooker whistle sample is filtered. Figure 4 shows the output after the cooker whistle sample is filtered.

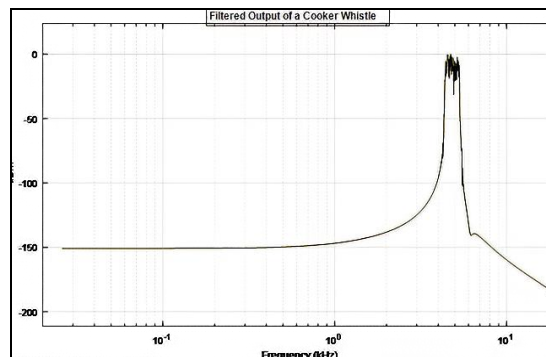

Figure 4 Spectrum of Filtered Cooker Whistle Audio Sample.

As illustrated in Figure 4, the frequencies which are not in the range of 5 to 6 kHz is removed and only the frequencies in the pass band are filtered out.

6.4 Whistle Counting Technique

There is a need of counting system to evidently show the working of the model and also to count the whistles. This is done by detecting the occurrence of peaks in the filtered signal by using a Maxima Finder and count it using a Counter and displaying the count value. The peaks within the particular threshold are ignored taking into consideration of the passband ripples, so that it only detects the peak that occurs due to the whistle. The filter when combined with the above counter then the whistle will be detected and will be counted or incremented.

VII. HARDWARE DEVELOPMENT OF SMART IOT KITCHEN

The hardware development part includes two main processes Deployment of Expert systems in Arduino and Establishment of Sensor and Cloud Connectivity. The expert systems are deployed in Arduino MEGA and the cloud connectivity is done using NodeMCU ESP8266

7.1 Deployment of Expert Systems in Arduino

The hardware implementation of fuzzy can be done by downloading an Addon which can make both Arduino and MATLAB independent by deploying it to hardware or dependent by running the program. The output from the Fuzzy logic controller is then given to a relational operator which gives a high output (Makes pin 9 of Arduino high) when the fuzzy logic gives a value greater than zero and an LED is connected. This is to verify whether the system works independently of MATLAB when deployed to hardware. The data is sent to the serial pins so that the output can be viewed in the SIMULINK screen when it is run as Hardware in loop. The output from “Hardware in Loop” is in Figure 5 (a) and independency of Arduino is tested and shown in Figure 5 (b).

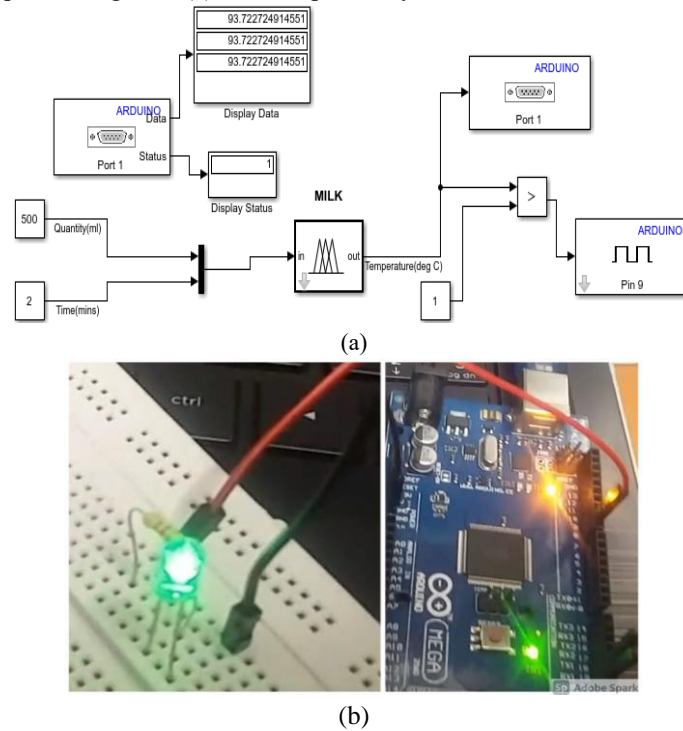

Figure 5 (a) “Hardware in Loop” for type Milk (b) Hardware Independency Testing for Milk.

For the input quantity of milk and amount of time it is be cooked, the output is processed in the microcontroller and the results are displayed via serial ports, also the hardware independency can be verified by deploying the system into Arduino which is illustrated in Figure 5. A Similar process can be followed to implement the signal processing for cooker whistle identification in Arduino.

7.2 Establishment of Sensor and Cloud Connectivity

Inventory Management and Kitchen Safety involves the usage of sensors and data transmission via Wi-Fi to Firebase cloud. This can be achieved by using a Node MCU module which has IO ports along with the inbuilt Wi-Fi Module. The process starts with scaling of sensors to downloading the appropriate Libraries and Modules is explained below.

7.2.1 Scaling of Sensors

Ultrasonic sensor is used in measuring inventory levels. The Ultrasonic sensor gives time difference in microseconds as output. The distance is calculated by the formula:

$$\text{Distance} = \frac{(\text{time} * (\text{speed of sound}))}{2} \tag{7}$$

where the speed of sound is 340 m/s and the output obtained from the sensor is in microseconds. Speed of sound in cm/μs is

$$340 * \frac{100}{100000} \text{ cm}/\mu\text{s} \tag{8}$$

So, by substituting Eq.(8) in Eq.(7) we get,

$$\text{Distance (in cm)} = \frac{(\text{time} \times 0.034)}{2} \quad (9)$$

It is then converted to a relative value in percentage by assuming the height of the container as 25 cm by using the formula in Eq.(10)

$$\text{Amount present} = \frac{\text{Container Height} - \text{distance(Measured)}}{\text{Container Height}} * 100 \% \quad (10)$$

The output from the kitchen safety sensor (Gas sensor) is an analog value proportional to ppm. It is then digitalised by the in-built ADC and that value will be equal to the ppm.

7.2.2 Steps Involved in connecting Sensors to Cloud

First step is to add the esp8266 as an additional board in the IDE and then downloading it in the board's manager. The library which will help with connecting to the cloud is then downloaded as an additional library and is added to the IDE. Then the additional supporting library for the IDE is downloaded. After doing this, the Node MCU is connected to working machine. The serial monitor from IDE displays the output from Smoke Sensor. When the smoke sensor detects smoke that is if value from sensor becomes more than the threshold value then there will be a notification in the mobile application regarding kitchen safety and also the circuit breaker will be given a trip signal so that the power supply can be cut off.

VIII. CONCLUSION

Fuzzy Logic is applied to both the induction stove and Wet Grinder. Results were obtained and were verified logically. The fuzzy system is being deployed into Arduino MEGA by using an Add-on. The hardware is then tested for independence, the program is executed in the Arduino and the output values are observed via serial ports in Simulink Screen. The audio samples are gathered and saved on the computer locally. To determine if it is a whistle, the stored audio signals are read as input and filtered with a band-pass filter. The whistle is counted using peak finder and counter. The app is developed and connected with Firebase and the value entered there is read via an app. Shopping List is provided based on the inventory levels. Expiry date management is obtained from the user and will notify before 10 days of the Expiry date and on the expiry date. The hardware component for inventory management and kitchen protection involves sending data from sensors to the cloud. Even if the consumer is not at home, the value of the sensor is known. The Future research that can be done on this is in the hardware implementation of fuzzy in Arduino, if the input is received by Keypad and if output is viewed in an LCD, the system can be made completely independent and similarly, if the whistle samples are collected in a microphone and the count and displayed in the LCD screen, then the system will become independent.

REFERENCES

- [1] K. Sakthisudhan, S. Mohanraj, and T. V. P. Sundararajan, "A smart kitchen automation and grocery management system using IoT", *International Journal of Recent Technology and Engineering*, vol. 8, no. 1, pp. 2368–2373, 2019.
- [2] M. G. Perumal, K. Srivatsan, P. Vijayakumar, R. Krishnaprasanna, and R. Rajashree, "IOT based smart kitchen system," *International Journal of Civil Engineering and Technology*, vol. 9, no. 11, pp. 737–749, 2018.
- [3] Varma, S. Prabhakar, and K. Jayavel, "Gas Leakage Detection and Smart Alerting and prediction using IoT," *Proceedings of the 2017 2nd International Conference on Computing and Communications Technologies, ICCCT 2017*, pp. 327–333, 2017.
- [4] K.A. Maheshwari P. Bagavathi Sivakumar, "Wireless IoT Based Smart Parking Solutions using Sensor Technology in the Context of Planned Smart Cities in India," *Journal of Engineering and Applied Sciences*, vol. 12, no. 8 SI, pp. 8302–8308, 2017.
- [5] S. Sharad, P. B. Sivakumar, and V. A. Narayanan, "The smart bus for a smart city - A real-time implementation," Jun. 2017.
- [6] L. L. Hnin, U. Z. Min, M. Htun, and H. M. Tun, "Fuzzy Logic Temperature Control System For The Induction

- Furnace,” *International Journal Of Secientific & Technology Research*, vol. 5, no. 6, pp. 130–134, 2016.
- [7] S. Jayapoorani and V. Manju, “Design of novel rice grinding machine,” *Pakistan Journal of Biotechnology*, vol. 13, pp. 171–173, 2016.
- [8] S. Anjana and P. Maya, “Fuzzy logic control of shunt active power filter for power quality improvement,” in *Advances in Intelligent Systems and Computing*, 2016, vol. 397, pp. 975–985, 2016.
- [9] S.P. Anbuudayasankar, Ramesh Srikanthan, Margabandu Karthik, Prashant R. Nair, Nagarajan Sivakarthik, Packirisamy Indukumar, “Cloud-based technology for small and medium scale enterprises: a decision-making paradigm using IPA, AHP and fuzzy-AHP techniques,” *International Journal of Integrated Supply Management*, vol. 13, no. 4, pp. 335–352, 2020.
- [10] P. K. Dhar, H. S. Jun, and J. M. Kim, “Design and implementation of digital filters for audio signal processing,” *Proceedings of IFOST-2008 - 3rd International Forum on Strategic Technologies*, pp. 332–335, 2008.
- [11] Haritha, M. Ganesan, and E. P. Sumesh, “A survey on modern trends in ECG noise removal techniques,” Aug. 2016.
- [12] S. . Balamurugan, B. M. . Shanthini, R. R. . Lekshmi, and K. R. M. V. Chandrakala, “Fuzzy Based Tariff,” *Journal of Electrical Systems.*, vol. 10, no. 4, pp. 465–471, 2014.
- [13] Mathworks, “Adaptive Fuzzy Inference System Toolbox,” Mathworks, 2020.