

¹Hae-Jun Lee

The Application of Artificial Intelligence (Ai) and Internet of Things (Iot) Middleware in Agriculture



Abstract: - Artificial intelligence (AI) devices like master frameworks, regular language handling, discourse acknowledgment, and machine vision have modified both the amount and nature of work in the rural area because of the developing worldwide populace, the rising interest for food, as well as changes in climate and the availability of water. Specialists and researchers are presently attempting to involve new IoT advances in savvy cultivating to help ranchers in making better seeds, crop assurance, and manures utilizing AI technology. Both the nation's overall economy and the profitability of ranchers will be benefited from this. Farming robots, prescient investigation, and soil and yield observing are the three main regions where AI is beginning to appear. In this sense, ranchers are utilizing sensors and soil test all the more often to gather information that the executives frameworks might use for more examination. Through an outline of AI applications in the farming business, this paper makes a commitment to the area. It starts with a prologue to AI and an investigation of all AI strategies utilized in the horticultural area, including AI, the Internet of Things using Universal Middleware, master frameworks, picture handling, and PC vision. This study incorporates a complete examination of the literature to research how artificial intelligence (AI) and the Internet of Things (IoT) are utilized in farming.

Keywords: Artificial Intelligence, Internet of Things (IoT), Systematic literature review, AI technology, Agriculture

I. INTRODUCTION

Information technology is used in smart farming to optimize intricate agricultural systems. In order to enhance the agricultural production system, it uses information and communication technology. One of the most significant producing areas is agriculture. It is separated into the three main subsectors of yields, ranger service, domesticated animals (creation and creature wellbeing), and hydroponics. It is associated with all features of agrarian movement. Artificial intelligence (AI) alludes to a wide assortment of software engineering applications that pertain to the expected improvement of shrewd PCs, robots, or sensors that might impersonate human exercises to do undertakings for the benefit of individuals and cleverly serve society. Using data processing and learning technology gadgets, application programs manage these activities. Brilliant agribusiness, which consolidates AI methods and customary horticultural practices, utilizes accuracy cultivating to screen crop improvement and lift public economies [1].

The manner in which technology has impacted pretty much every part of our lives isn't remarkable to us. Things like fans, air conditioners, coolers, plants, entryways, and a lot more can chat with each other and make decisions on real conditions with practically any human info. In all fields, including brilliant homes, wearables, shrewd urban communities, savvy frameworks such as Universal Middleware, Open Service Gateway initiative(OSGi) and Dynamic Service Platform, connected vehicles, the Modern Internet, store network the executives, medical care, and o forth, artificial intelligence (AI) and the Internet of Things (IoT) made a critical commitment [2]. IoT is a large group of varied linked devices that use multiple protocols and architectural designs to communicate with one another and carry out predetermined actions on sensor data acquired. Things become smarter and defensible judgments are made without human intervention when AI and IoT are integrated [3].

We examined the data coming from the many gadgets that surround us as we join the modern world. When this data is processed, AI is particularly important in IoT devices [4].

Agriculture is no longer an exception in this decade of unprecedented technological advancement. Agriculture-related operations were also significantly influenced by AI and IoT. According to research, agriculture contributes between 17 and 18% of India's overall GDP [5]. For further developed crop creation, it depends on various inward and outside perspectives that are challenging to expect ahead of time, for example, knowing weather conditions,

¹ IWCR, Kangnam University, 40 Gangnam-Ro, Giheung-Gu, Yongin-Si, Gyeonggi-Do, Republic of Korea

Haejuna@Gmail.Com

Copyright © JES 2024 on-line : journal.esrgroups.org

manure use, soil quality, bug control, crop wellbeing, , weed administration, rise or decrease in temperature, and so on.

Ordinarily utilized techniques miss the mark regarding creating the best results, especially with regards to foreseeing how a yield will act and how much water it will require. Supplement worth will be harmed whenever used in overabundance, while crop development will be upset whenever utilized in deficient sums. Water is squandered in irrigational processes by around 60% [6].

Both AI and the Internet of Things (IoT) help with gathering sensor information, handling it, and recognizing key components that at last aid in crop creation [7]. The farming system considers various factors, including temperature, rainfall figure, weed control, water administration soil the board, crop wellbeing checking, and weed control.

Each field, including robotized water system frameworks, agrarian checking models, information examination sought after and supply, crop infection forecast with picture handling, and the exact utilization of pesticides with the aid of sensors, benefited enormously from the IoT and AI. What's more, the Indian government has sent off various fruitful projects around here, including the Electronic Public Agribusiness Market (eNAM), Public Mission for Sustainable Horticulture (NMSA), Pradhan Mantri Krishi Sinchai Yojana (PMKSY), Pradhan Mantri Fasal Bima Yojana (PMFBY), and numerous others [8].

The combination of technology and agribusiness has made life simpler for ranchers since they never again need to visit every one of the fields around evening time and remain there until the power or water supply is turned on [9].

Precision farming, smart farming, and digital farming are new ideas in agriculture that are being introduced through an increasing number of new approaches, tools, and procedures [10].

The accompanying exercises can be generally dealt with using different utilizations of artificial intelligence in farming:

- Checking of soil and yields (screen the harvest wellbeing). AI might be utilized by organizations to appraise agrarian yields and figure the most profitable time for gathering by constantly observing harvests and soil wellbeing.
- Finding of problems (early arrangement of plant sicknesses assists with utilizing the appropriate methodology to battle it). Ranchers will actually want to apply the best sickness battling procedures with the early order of plant diseases.
- A robot for cultivating (handling the work difficulties). Reaping assignments might be finished quicker and all the more precisely for representatives by utilizing robots, sensors, machine vision, AI models, and AI frameworks.
- Guesses (Empowers right direction)
- Crop yield anticipating (foreseeing the best chance to plant). It is possible to gauge the best second to prepare fields and sow seeds utilizing artificial intelligence techniques and devices, bringing about a better return and better valuing with impeccable timing.
- Strategic spraying (allows for cost savings). The loss of crops in the field caused by the conventional technique of harvesting is decreased with the use of intelligent spraying. Chemical spraying is regarded as a crucial technique for managing plant diseases caused by bacteria, fungus, and pest insects.

The number of inhabitants in the globe will rapidly ascend from 7.8 billion out of 2020 to around 11 billion before long, as per projections from the Unified Countries. By 2025, there will be 8 billion individuals in the world, and there will be 9.6 billion toward the finish of 2050, as per the FAO [11]. To meet the tremendous ascent in populace, the world must subsequently grow food accordingly. Customary agrarian strategies are lacking to satisfy the rising need for food since ranchers should support yield as well as give better food to shoppers. It is accentuated that various classes of IoT applications, robotization, AI, profound learning, and AI methods ought to be utilized successfully to increment the creation of food as well as the nature of the delivered food on the grounds that the worldwide populace is developing very rapidly and the interest for food is expanding close by the expansion in population[12]. Figure 1 shows the possible ways AI can prove beneficial in agriculture.



Figure: 1 Agriculture and Artificial Intelligence

A few search queries (Table 1) pertinent to how AI and IoT are utilized in addressing horticultural troubles were utilized to separate substance from peer-reviewed scholastic distributions and meetings to secure information zeroing in on the essential parts of this SLR. The data was obtained from the Horticulture Science Data set, Science Direct, and Google Researcher, among different spots.

Table 1: For information recovery during exploratory recognizable proof, use search strings

Search Terms	About the results
“Agricultural Practices AND Artificial Intelligence”	89 900
“Agriculture AND "Internet of Things”	44 255
“"Agriculture" AND "Machine learning”	42 22
“Agribusiness AND "Smart sensors”	75 22
“4.0 Agriculture”	4 55
“shrewd farming”	47 2
“Precision farming”	75 3

Precision farming is an optimization strategy that incorporates field and crop specific observation, measurement, and analysis. Robotics and big data & advanced analytics are two potential technologies that control precision agriculture. The 4 R's, or right time, right location, right amount, and right manner, more accurately describe it [13].”

"Smart farming":Refers to the method of gathering data from the field and the clever use of that data to carry out the intended operations. It uses data and digital technology and affects all aspects of agricultural operations [14].”

II. DIGITAL FARMING

“Digital farming” is an idea in light of both brilliant cultivating and accuracy cultivating. The strategy gives the information that has been assembled esteem and produces decisions that might be executed for sometime in the future. Also, as it offers clients knowledgebase data, it is invaluable for users [154].”

In spite of the reception of a few contemporary strategies, there are as yet various issues that should be settled to work on cultivating. The objective of the ongoing review piece is to look at a few demonstrated systems utilized in contemporary farming and to represent these procedures’ true capacity for what’s to come. Figure 2 shows WSN node architecture including Universal Middleware.

Broad examination is as yet required in creating areas important to observably affect enormous scope ranches in created nations as well as on limited scope ranches in emerging nations [16]. Notwithstanding the way that the utilization of IoT and the reception of accuracy horticulture can extraordinarily work on the general yield and cultivating practices of ranchers.

Focus must be given to how these advances might be made available to non-industrial countries and country locales since the reception of accuracy horticulture depends on something other than the utilization of these technology on business ranches.

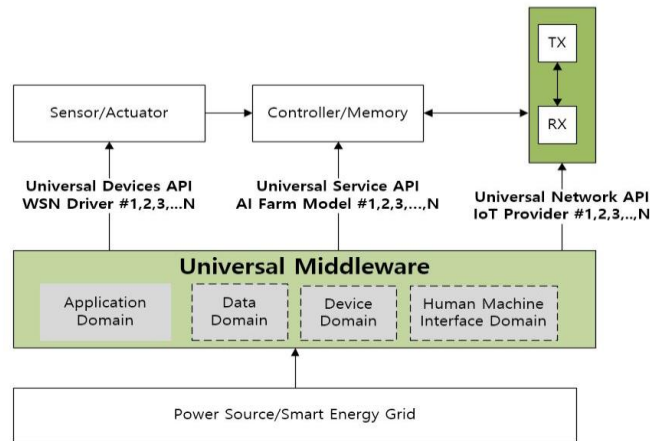

Figure 2: WSN node architecture including Universal Middleware

It is necessary to develop a network and computer system for rural regions that is more effective and dependable in terms of energy supply, network latency, throughput, and performance. This improves access to the advantages of precision agriculture by reducing network delay in locations with lower connection and greater bandwidth limits [17]. This will facilitate the availability of emerging small-scale farmers to resources for cyclical farming that have the potential to improve production and maybe other aspects of agricultural output.

III. SYSTEMATIC REVIEW METHODOLOGY

Perhaps one of the most important aspect of human life on this planet is the food and agriculture. To address various issues, this industry might profit from AI and its subfields, including AI, PC vision, and picture handling. While AI strategies can be utilized in these cycles during preproduction (crop yield and finding water system spills), creation (sickness location and climate expectation), handling (item assessment), and circulation (stockpiling and customer examination), IoT gear can be utilized to gather valuable data from crude information on ranches in regards to agribusiness and water system[18]. Creators ought to investigate, fathom, and classify the latest examination distributions in their field of revenue prior to doing investigation and reaching resolutions in light of their outcomes. We searched for diary articles, meeting papers, and book sections that examined AI and IoT applications in agribusiness for the momentum literature study. We focused on legitimate works recorded in Scopus, Clarivate, and IEEE Xplore [19]. Figure 3. Gives the steps involved in the systematic literature review utilized for this work.

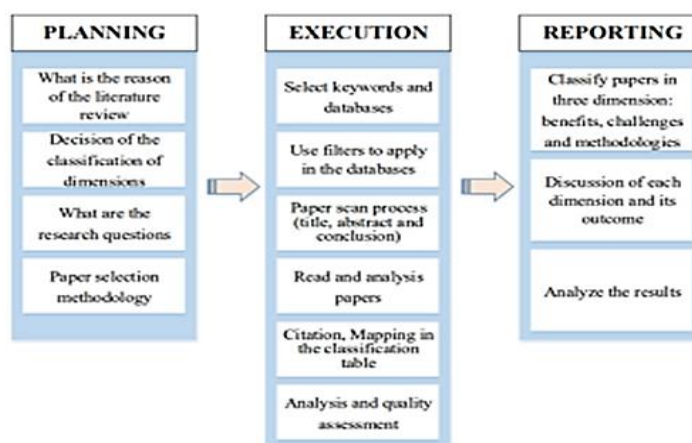

Figure 3: Steps of a systematic literature review

3.1. Three stages are followed to accomplish a systematic review:

3.1.1. Preparing, Carrying Out, and Reporting

The justifications for doing a literature review in a particular field are taken into account during the planning stage. In this example, various novel applications are introduced, including efficiency, harvest and animals checking,

abnormal action recognition, water system spillage location, and observing. The most advantageous AI draws near, including AI, master frameworks, the Internet of Things, and picture/video handling, are likewise investigated notwithstanding these application areas [20].

IV. AGRICULTURAL SECTOR

From several angles, smart farming technologies have a significant impact on the agricultural industry. The effectiveness of water use, for instance, will benefit from observations and data collection from big farms on humidity, air temperature, soil moisture, and solar intensity. As a result, it will have an impact on agricultural output as a whole. Since the population of the globe is growing every day, it is crucial to employ innovative agricultural practices to boost food output. The ideal method for boosting food output and maximizing profit is, therefore, smart farming. Utilizing IoT platforms and inexpensive sensors, smart agricultural solutions should be put into practice efficiently while conserving time, money, and resources. The agricultural industry will gain from these implementations in a variety of ways, including enhanced animal farming, remote monitoring of fields, decreased environmental footprints, real-time data collecting, cheaper operating costs, and higher output quality [21].

Smart farming research and development is encouraged in many nations in order to increase sustainable food production and improve farmer profitability. One instance of smart farming being used in the agriculture industry was given. They tended to the troubles related with doing such drives while considering the availability of completely useful examination offices, HR, and ecological contemplations [22].

Figure 4. illustrates AI technology of an IoT savvy cultivating framework. Drones, Wi-Fi bots, and IoT sensors (like optical, electrochemical, mechanical soil, area, and airflow sensors) assemble information from the fields and send it to the AI-based brilliant cultivating framework through the cloud. Savvy cultivating frameworks remove data from unstructured information and assist with cultivating the executives and navigation by utilizing an assortment of AI, picture handling, PC vision, remote detecting, and master framework techniques. These techniques work on rural and supply organizations' quality, efficiency, and sustainability [23].

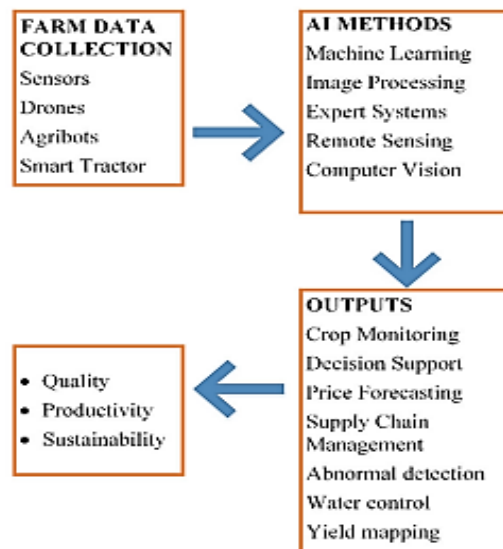

Figure 4: IoT smart agricultural system with AI

proposed an IoT-based strategy for "digital farming" to assess agricultural output. IoT sensors gather information from farms, assisting farmers in decision-making and crop monitoring. Applications for smartphones and the web are particularly effective in distributing product information and facilitating online shopping. Contrasted several AI- and IoT-based agricultural approaches to established farming practices [24]. Their discoveries exhibit that AI-based rural creation is more successful and worthwhile, and that ranchers who practice shrewd cultivating have better Satisfaction Record scores and expectations for everyday comforts than ranchers who utilize traditional farming [25].

V. CONCLUSION

Smart farming is an idea that incorporates endlessly overseeing ranches using current advances like IoT, robots, and AI to raise the amount and nature of merchandise while diminishing the requirement for human work underway [26]. Considering that populace numbers are rising quickly all over the globe, these benefits will well affect the economy's profitability and extension. To help ranchers in utilizing AI technology to produce better seeds, crop security, and manures, specialists and researchers are pushing toward the utilization of recently delivered IoT advances in shrewd cultivating.

The most current uses of AI techniques in smart farming have also been covered in this study, with an emphasis on the AI techniques or algorithms employed and the accuracy rates attained [27]. Tables were presented to show the most current AI methodology, their related applications, and the accuracy levels attained. Researchers have seen highly encouraging outcomes when successfully using AI methodologies. This study has offered comprehensive explanations of AI applications in smart farming. To sum up, the idea of smart farming and precision agriculture is to improve agricultural civilization, and it seems that the only way agriculture will flourish is if most farmers adopt these technologies into their farming methods [28].

Acknowledgements

Funding

This research did not receive any specific grant from funding agencies in the public. ~~((Not Yet fixed Research Number, If the assignment number is confirmed during the thesis editing period, an acknowledgment will be indicated as follows. This work was supported by the National Research Foundation of Korea grant funded by the Korea government.~~

Authors' contributions

Professor Debnath Bhattacharyya of K L University in India was not included as the author of the paper due to personal reasons, but I would like to express my special thanks to him for his advice and help in writing the paper.

Declaration of Conflicts of Interests

Authors declare that they have no conflict of interest.

Consent for Publication

All authors read and aware of publishing the manuscript in xxxxxxxx

Data Availability Statement

The database generated and /or analysed during the current study are not publicly available due to privacy, but are available from the corresponding author on reasonable request.

Declarations

Author(s) declare that all works are original and this manuscript has not been published in any other journal.

REFERENCES

- [1] G. S. Nagaraja, A. B. Soppimath, T. Soumya, and A. Abhinith, "IoT based smart agriculture management system," in Proc. 4th Int. Conf. Comput. Syst. Inf. Technol. Sustain. Solution (CSITSS), Dec. 2019, pp. 1–5.
- [2] Lee. Hae-Jun, Dynamic Context Awareness of Universal Middleware based for IoT SNMP Service Platform. Technical Journal, vol.17, no. 2, pp. 185-191, 2023.
- [3] Sivaganesan D, "Design and Development AI-Enabled Edge Computing for Intelligent-IOT Applications," JTCSSST , vol. 1, no. 2, pp. 84-94, 2019.
- [4] Kumari D, Pandita R, Mittal M, "An Agricultural Perspective in Internet of Things," IJCSE, vol. 6, no. 5, pp. 107-110, 2018.

- [5] Vincent DR, Deepa N, Elavarasan D, Srinivasan K, Chauhdary SH, Iwendi C, "Sensors Driven AI-Based Agriculture Recommendation Model for Assessing Land Suitability," *Sensors*, vol. 19, no. 17, p. 3667.
- [6] Kamar, Praveen S "A Study on the role of E-Technology to take over Agriculture Distress in India," *IJCAS*, vol. 8, no. 12(A), pp. 335-341, 2018.
- [7] Puranik V, Ranjan A, Kumari A, "Automation in Agriculture and IoT," in *IEEE*, 2019.
- [8] Kumar S, Chowdhary G, Udutalapally V, Das D, Mohanty SP, "gCrop: Internet-of-Leaf-Things (IoLT) for Monitoring of the Growth of Crops in Smart Agriculture," in *IEEE*, 2019.
- [9] David S, Anand RS, Sagayam M, "Enhancing AI based evaluation for smart cultivation and crop testing using agro-datasets," *JAIS*, vol. 2, no. 1, pp. 149-167, 2020.
- [10] Raju BV, "An IOT based Low Cost Agriculture Field Monitoring System," *JASC*, vol. VI, no. IV, pp. 128136, 2019.
- [11] Ragavi B, Pavithra L, Sandhiyadevi P, Mohanapriya GK, Harikirubha S, "Smart Agriculture with AI Sensor by Using Agrobot," in *IEEE*, 2020.
- [12] United Nation Global Population Growth and Sustainable Development. Accessed: Apr. 11, 2022.
- [13] (Oct. 2009). How to Feed the World 2050. Accessed: Jun. 28, 2022. [Online].
- [14] Kamar, Praveen S "A Study on the role of E-Technology to take over Agriculture Distress in India," *IJCAS*, vol. 8, no. 12(A), pp. 335-341, 2018.
- [15] Puranik V, Ranjan A, Kumari A, "Automation in Agriculture and IoT," in *IEEE*, 2019.
- [16] Kumar S, Chowdhary G, Udutalapally V, Das D, Mohanty SP, "gCrop: Internet-of-Leaf-Things (IoLT) for Monitoring of the Growth of Crops in Smart Agriculture," in *IEEE*, 2019.
- [17] David S, Anand RS, Sagayam M, "Enhancing AI based evaluation for smart cultivation and crop testing using agro-datasets," *JAIS*, vol. 2, no. 1, pp. 149-167, 2020.
- [18] Raju BV, "An IOT based Low Cost Agriculture Field Monitoring System," *JASC*, vol. VI, no. IV, pp. 128136, 2019.
- [19] F. Kiani and A. Seyyedabbasi, "Wireless sensor network and Internet of Things in precision agriculture," *Int. J. Adv. Comput. Sci. Appl.*, vol. 9, no. 6, pp. 1–5, 2018.
- [20] O. Elijah, T. A. Rahman, I. Orikumhi, C. Y. Leow, and M. N. Hindia, "An overview of Internet of Things (IoT) and data analytics in agriculture: Benefits and challenges," *IEEE Internet Things J.*, vol. 5, no. 5, pp. 3758–3773, Oct. 2018.
- [21] E. Collado, A. Fossatti, and Y. Saez, "Smart farming: A potential solution towards a modern and sustainable agriculture in Panama," *AIMS Agricult. Food*, vol. 4, no. 2, pp. 266–284, 2019.
- [22] A. R. de Araujo Zanella, E. da Silva, and L. C. P. Albini, "Security challenges to smart agriculture: Current state, key issues, and future directions," *Array*, vol. 8, Dec. 2020, Art.
- [23] H. P. Thakor and S. Iyer, "Development and analysis of smart digifarming robust model for production optimization in agriculture," in *Proc. 6th Int. Conf. Comput. Sustain. Global Develop. (INDIACom)*, 2019, pp. 461–465.
- [24] P. Suebsombut, A. Sekhari, P. Sureepong, P. Ueasangkomsate, and A. Bouras, "The using of bibliometric analysis to classify trends and future directions on 'smart farm,'" in *Proc. Int. Conf. Digit. Arts, Media Technol. (ICDAMT)*, 2017.
- [25] Kumar S, Raja P, Bhargavi G, "A Comparative Study on Modern Smart Irrigation System and Monitoring the Field by using IOT," in *IEEE*, 2018.
- [26] Mane SS, Mane MS, Kadam US, Patil ST, "Design and Development of Cost Effective Real Time Soil Moisture based Automatic Irrigation System with GSM," *IRJET*, vol. 6, no. 9, pp. 1744-1751, 2019.
- [27] Patange MS, Student PG, Farooqui MZ, "IOT Assisted Farming," *RJSE*, vol. 3, no. 7, pp. 736-739, 2019.
- [28] Bhagwat SD, Hulloli AI, Patil SB, Khan AA, Kamble MA, "Smart Green House using IOT and Cloud Computing," *IRJET*, vol. 5, no. 3, pp. 2330-2333, 2018.