

^{1*}Guanghong Xin²Haozheng Xie³Shuo Kang

Design and Development of an Intelligent Connected Access Integrated Training and Assessment Platform



Abstract: - This study addresses the issues of poor interdisciplinary integration and misalignment between experimental content and industry demands in the construction of applied undergraduate laboratory facilities, based on the background of industry-academia collaboration. This paper presents the design and development of an intelligent connected access integrated training and assessment platform, utilizing a full-stack development approach that combines knowledge graph, sensor principles, communication protocol integration, microcontroller programming, networking, connected access, and cloud platform development. The platform adopts a topological hierarchical structure, facilitating layered instruction for teachers and helping students to understand the logical development of Internet of Things products. Furthermore, the platform utilizes equipment commonly used in enterprises to enhance students' technical application, practical, and innovative capabilities. Through teaching practice, students' engineering awareness and practical skills have significantly improved, effectively promoting the development of relevant courses and practical training.

Keywords: Industry-academia Collaboration, Interdisciplinary Integration, Topological Hierarchy, Knowledge Graph, Intelligent Connected, Training and Assessment Platform.

I. INTRODUCTION

China is vigorously promoting the implementation of the strategy to become a manufacturing powerhouse in the new stage of economic development. However, the impact of the global COVID-19 pandemic and changes in the international landscape have further highlighted the urgency of this strategy and raised higher requirements for cultivating new talents in applied engineering disciplines. To adapt to the needs of the industry, strengthen industry-academia collaboration, and advance the implementation of engineering education, it is necessary to emphasize the cooperation between universities and enterprises. Such collaborative efforts can not only better meet the industry's demands but also cultivate engineering talents with practical abilities [1-2]. Currently, the construction of laboratories in local applied undergraduate institutions faces various challenges, such as poor interdisciplinary integration in practical teaching platforms, detachment between experimental content and industry demands, lack of innovative practical environments, and high maintenance costs [3-4]. To address these issues, this paper proposes the design of an intelligent connected access integrated training and assessment platform. This platform integrates full-stack technologies, including knowledge graph-based integration of sensor principles, communication protocol integration, microcontroller programming, networking, connected access, and cloud platform development, to improve the interdisciplinary integration of the practical platform and encourage the integration of theoretical knowledge and practical operations for students. Moreover, the platform utilizes commonly used equipment in enterprises to bridge the gap between textbook knowledge and industry demands. Additionally, the platform provides a comprehensive training and assessment environment with teaching plans, encouraging students to engage in independent exploratory learning and practical operations. Finally, the platform adopts a modular design to reduce maintenance costs.

II. PLATFORM STRUCTURE AND FUNCTIONAL DESIGN

A. Topological Hierarchical Structure Design

To facilitate layered instruction for teachers and help students understand the logical development of Internet of Things engineering product development, the platform adopts a topological hierarchical design. Figure 1 illustrates the conceptual diagram of the design approach. After the microcontroller collects data from transmitter devices using different embedded communication protocols and data acquisition methods, the platform enables full-stack development from sensor principles, communication protocol integration, microcontroller programming, networking, connected access, to cloud platform development through networking and connected access. This concept is further materialized in the layout diagram of the intelligent connected access integrated training and

¹ College of New Energy and Intelligent Connected Vehicles, University of Sanya, Sanya, 572000, China

² College of New Energy and Intelligent Connected Vehicles, University of Sanya, Sanya, 572000, China

³ College of New Energy and Intelligent Connected Vehicles, University of Sanya, Sanya, 572000, China

*Corresponding author: Guanghong Xin

Copyright © JES 2024 on-line : journal.esrgroups.org

assessment platform shown in Figure 2. From bottom to top, the layers consist of the microcontroller selection module layer, transmitter device integration layer, interaction layer, networking selection layer, and connected access layer, corresponding to the numbers 6, 4, 5, 3, and 2 in Figure 2. This layout reflects the basic process of intelligent connected product development. Additionally, the back of the platform is equipped with a multi-source dynamic power module and a 16-channel relay controller module, labeled as 7 and 8, respectively, for module power control. In terms of framework materials, the platform is constructed and assembled using aluminum profiles and basic components, labeled as 1. This design is simple, convenient for assembly, and cost-effective.

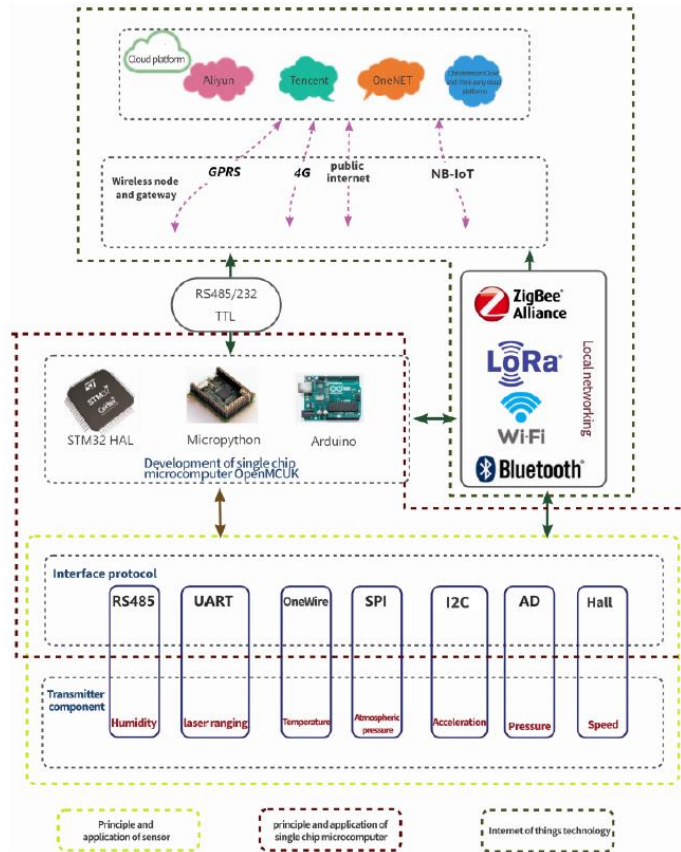

Figure 1: Topological Hierarchical Diagram of the Intelligent Connected Access Integrated Training and Assessment Platform

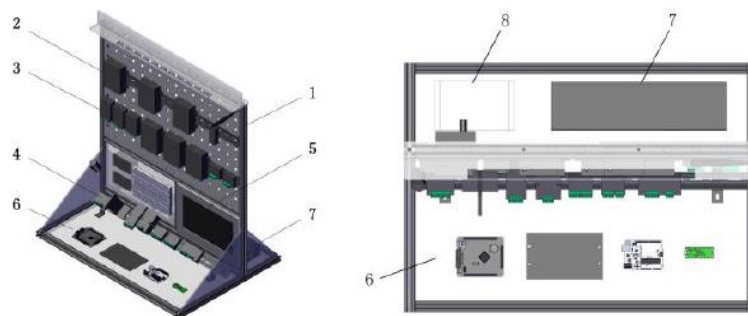

Figure 2: Structural Layout Diagram of the Intelligent Connected Access Integrated Training and Assessment Platform

Note: Numbers 1-8 correspond to the aluminum profile framework, connected access layer, networking selection layer, transmitter device integration layer, interaction layer, microcontroller selection module layer, multi-source dynamic power module, and 16-channel relay controller module.

B. Functional Design Based on Knowledge Graphs

The core of the intelligent connected access comprehensive training and assessment platform is to simulate real-world engineering product development and provide authentic exercises, allowing students to engage in practical activities such as component selection, network scheme selection, and connected access in actual projects. The knowledge graph, as shown in Figure 3, is constructed by organizing the course knowledge involved in the

full-stack development of intelligent connected access. The platform integrates three courses: sensor principles and applications, microcontroller principles and applications, and Internet of Things technologies, and divides them into functional module layers based on technical logic. Initially, the platform offers five common embedded communication protocols, one signal conversion technique commonly used in embedded development, and one measurement method for embedded systems. Corresponding typical transceiver devices are selected to establish the transceiver device access module layer, which primarily cultivates students' ability to acquire real environmental information using sensor technology [5]. Next, based on different microcontroller development approaches, the platform selects the STM32 microcontroller system developed using the HAL library, the Arduino microcontroller system based on open-source firmware, and the MicroPython microcontroller system based on interpreted execution programming. This establishes the microcontroller selection module layer, which aims to enable students to master the practical application and programming skills of different types of microcontrollers [6]. Subsequently, depending on the networking requirements, the platform selects Zigbee for short-distance low-power communication, LORA for long-distance low-rate communication, and Bluetooth for short-distance high-bandwidth communication as networking methods. This creates the network selection module layer, which primarily develops students' abilities in network planning and network scheme selection [7]. Lastly, considering different usage scenarios, the platform provides options such as low-power and cost-effective GPRS, wide coverage and fast transmission 4G, wide coverage and low-power NB-IoT, and flexible and low-cost local network-connected WIFI for connected access [8-10]. This establishes the connected access selection module layer, which focuses on teaching students how to connect IoT devices to networks and perform data transmission. Finally, the platform also incorporates different cloud platforms for connected access, including Alibaba Cloud, OneNET, and Youren Cloud, to facilitate student verification and demonstrations. These cloud platforms help students better grasp skills in handling and analyzing IoT data [11].

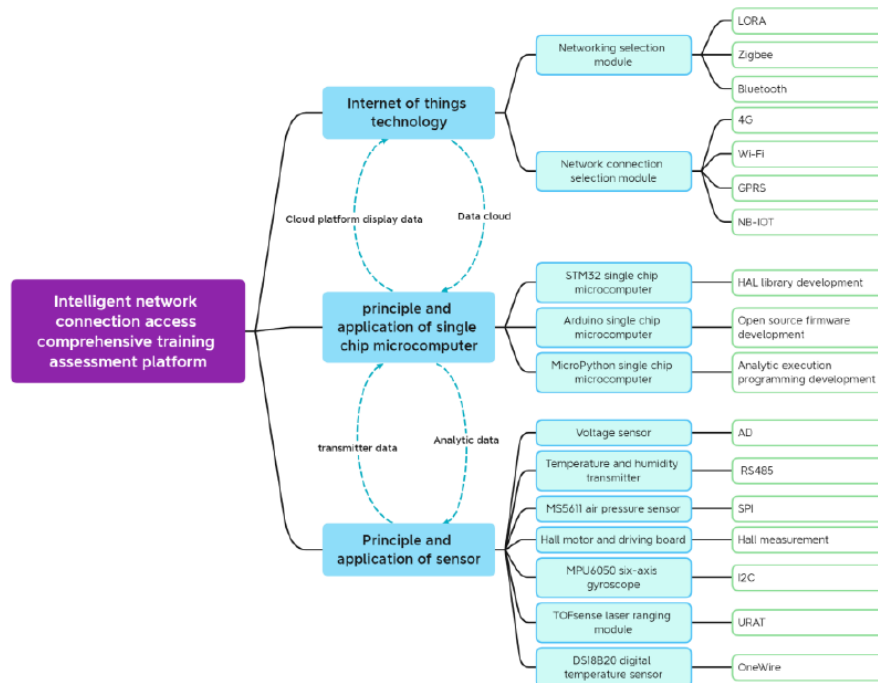

Figure 3: Knowledge Graph of the Intelligent Connected Access Comprehensive Training and Assessment Platform

III. PLATFORM MODULE DESIGN AND CORE COMPONENT SELECTION

The Intelligent Connected Access Comprehensive Training and Assessment Platform is built on an aluminum profile framework and includes the following functional modules: Transceiver Device Access Module, Microcontroller Selection Module, Network Selection Module, Connected Access Selection Module, Multi-Source Dynamic Power Supply Module, and Human-Machine Interaction Display Screen and Communication Converter Board. The main workflow of the platform is as follows: The Microcontroller Selection Module and Transceiver Device Access Module are connected to each other via a communication converter board, used for processing local data and generating processed data. At the same time, the Microcontroller Selection Module is connected to the Human-Machine Interaction Display Screen to display the processed data. Additionally, the Microcontroller

Selection Module is further connected to the Network Selection Module via the communication converter board, and finally, the Network Selection Module is connected to the Connected Access Selection Module to transmit the processed data to the cloud platform. The platform adopts a multi-module design concept, which provides high reliability and operability [12].

A. Multi-Source Dynamic Power Supply Module

The multi-source dynamic power supply module of the Intelligent Connected Access Comprehensive Training and Assessment Platform can respond in real-time to user operations on the human-machine interaction interface and provide suitable power supply to the devices. The circuit schematic of the multi-output power supply module is shown in Figure 4. Firstly, the multi-source dynamic power supply module divides the 220V AC power into two paths. One path controls the operation of the lights through a relay module, while the other path converts the 220V AC voltage to 24V and 5V DC voltages using the 220V-24V/5V module. Subsequently, the 24V DC voltage is further converted to 12V DC voltage through the 24V-12V module, and then the 12V DC voltage is converted to 3.3V DC voltage through the 12V-3.3V module to meet the power requirements of different electronic devices. Moreover, the multi-source dynamic power supply module is equipped with a Raspberry Pi Pico microcontroller as the main controller, which communicates with a 16-channel relay and an industrial control screen via the TTL-RS485 module, enabling intelligent and programmable control [13]. Additionally, to prevent interference and improve the stability of the multi-source dynamic power supply module, this design separates analog ground and digital ground and uses a 4.7 μ F inductor for isolation. Furthermore, for the safety and convenience of the system power supply module, a pluggable phoenix terminal is designed as the module's pin interface. Finally, the module also features a USB debugging port, supporting secondary development and software updates, facilitating user debugging and upgrades.

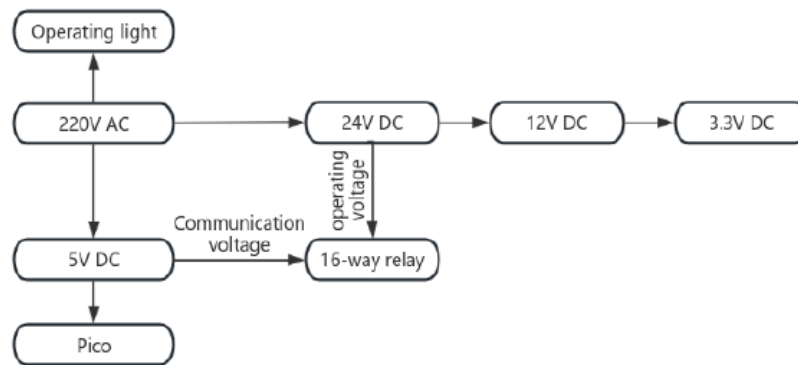

Figure 4: Circuit Structure Diagram of the Multi-Source Dynamic Power Supply Module

B. 16-Channel Relay Controller Module

The Intelligent Connected Access Comprehensive Training and Assessment Platform interfaces the 16-channel relay controller module with the four voltage outputs of the Multi-Source Dynamic Power Supply Module. This connection allows for the distribution of these outputs to various layer modules within the platform. The Raspberry Pi Pico, serving as the main controller of the Multi-Source Dynamic Power Supply Module, sends Modbus RTU standard commands to the 16-channel relay controller module via the TTL to RS485 module. These commands control the start-up of corresponding devices within the platform [14]. The 16-channel relay controller module plays a crucial role in the platform's operation. It receives commands from the main controller and executes them by controlling the relay outputs. These outputs are connected to various devices within the platform, allowing for precise control and monitoring of their operation. The use of Modbus RTU standard commands ensures compatibility with a wide range of devices and allows for easy integration into existing systems. The platform's architecture ensures efficient power distribution and control, providing users with a comprehensive training and assessment solution. The integration of the 16-channel relay controller module into the platform further enhances its capabilities, enabling users to remotely control and monitor devices through the main controller. This flexibility and expandability make the platform suitable for a wide range of applications, including but not limited to access control, security systems, and industrial automation.

C. Communication Converter Board

The Communication Converter Board is an integral part of an Intelligent Connected Access Integrated Training and Assessment Platform, serving as an important bridge connecting various modules within the platform. As

shown in Table 1, the board facilitates level conversions and supports six common embedded communication protocols and two data acquisition and measurement methods. The six embedded communication protocols covered by the board are RS485, RS232, SPI, I2C, OneWire, and UART [15]. Each of these protocols has its own specific voltage requirements for logic 1 and logic 0 states. For example, RS485 requires a logic 1 state of +2V to +6V and a logic 0 state of -2V to -6V. Similarly, RS232 has a logic 1 state ranging from -15V to -5V and a logic 0 state ranging from +5V to +15V. The board also supports two additional data acquisition and measurement methods: AD conversion and Hall measurement. The AD conversion method covers a voltage range from 0V to 5V, suitable for analog-to-digital conversions. The Hall measurement method operates at 5V and is typically used for speed measurements. The table also provides a logical mapping of the board, detailing how each communication protocol and data acquisition method is mapped to specific voltage levels during level conversions. This mapping ensures accurate signal transmission and reception between different modules within the platform.

Table 1: Logic Mapping Table of the Communication Converter Board

Embedded Communication Protocols and Data Acquisition	Methods Level Conversion
RS485	Logic 1:+2V—+6V Logic 0:-2V—-6V
RS232	Logic 1:-15V—-5V Logic 0:+5V—+15V
UART	Logic 1:3.3V—5V Logic 0:0V—0.3V
OneWire	Logic 1:3.3V—5V Logic 0:0V—0.3V
SPI	Logic 1:3.3V—5V Logic 0:0V—0.3V
I2C	Logic 1:3.3V—5V Logic 0:0V—0.3V
AD	0V—5V
Hall Measurement	5V

D. Transducer Access Module

This platform assists students in understanding the working principles and application scenarios of different embedded communication protocols by selecting representative transducer devices. The transducer access layer includes a temperature and humidity transducer, TOFSense laser ranging module, DS18B20 digital temperature sensor, MS5611 pressure sensor, and MPU6050 six-axis gyroscope. These devices utilize five classic embedded communication protocols: RS485, UART, single-wire, SPI, and I2C, corresponding to the numbered components in Figure 5: ③, ④, ⑥, ⑤, and ⑦, respectively. Additionally, this layer is equipped with a voltage sensor, Hall effect motor, and corresponding driver boards, identified as components ② and ①, respectively. The voltage sensor converts the collected analog signals into digital signals for data transmission using AD signal conversion technology, while the Hall effect motor utilizes Hall speed measurement to transmit real-time working status and velocity data. By utilizing these embedded communication protocols and transducer data acquisition methods, students can gain a better understanding of protocol selection and design methods in practical applications, thereby enhancing their overall awareness and practical skills in embedded system development.



Figure 5: Physical diagram of the transducer access module layer

Note: Numbered components ①-⑦ correspond to the Hall effect motor and its driver board, voltage sensor, temperature and humidity transducer, TOFSense laser ranging module, MS5611 pressure sensor, DS18B20 digital temperature sensor, and MPU6050 six-axis gyroscope, respectively.

E. Microcontroller Selection Module

The platform we are developing aims to provide an advanced embedded development platform that not only aids in teaching embedded system development but also helps learners enhance their competitiveness in the job

market. Given the vast array of embedded development tools available, selecting the right microcontroller was a crucial decision. Therefore, we have chosen three representative microcontrollers for our platform: the STM32 microcontroller based on the HAL (Hardware Abstraction Layer) library, the Arduino microcontroller based on open-source firmware, and the MicroPython microcontroller based on interpreted programming. The STM32 microcontroller, widely used in embedded systems, is based on the HAL library, which provides a simplified and efficient way to program the microcontroller. It offers excellent performance and a wide range of peripherals, making it suitable for complex embedded applications. The Arduino microcontroller, on the other hand, is known for its simplicity and ease of use. It utilizes open-source firmware, which allows users to program the microcontroller using a straightforward programming language. This simplicity makes it an excellent choice for beginners and hobbyists who are new to embedded development. Lastly, the MicroPython microcontroller, which is based on interpreted programming, offers a different programming paradigm. It allows users to program the microcontroller using a Python-like language, providing a more intuitive and familiar programming experience. This flexibility makes it suitable for rapid prototyping and teaching purposes. By offering options based on these three different microcontrollers, our platform caters to a wide range of development needs and learning styles. Learners can choose the microcontroller that best suits their requirements and interests, whether they are experienced embedded developers or hobbyists new to the field.

F. Networking Selection Module

The Networking Selection Module plays a crucial role in enhancing students' understanding of various wireless networking technologies and providing hands-on experience in constructing wireless networks for device interconnectivity. This module incorporates three widely adopted wireless networking devices: Zigbee, LORA, and Bluetooth. Zigbee is employed for short-range communication, emphasizing low-power consumption. It allows devices to communicate efficiently over short distances, making it an excellent choice for applications where power efficiency is critical. LORA, on the other hand, facilitates long-range communication with low data rates. It is designed for applications that demand extended coverage and do not require high data transmission speeds. By integrating LORA into the platform, students can gain insights into the challenges and benefits associated with long-range wireless communication. To address short-range, high-bandwidth communication requirements, the platform incorporates Bluetooth technology. Bluetooth enables rapid data transfer and supports high-bandwidth applications. By utilizing Bluetooth, students can explore the potential of wireless connectivity in scenarios that demand fast and reliable data transmission, such as multimedia streaming or file sharing. By encompassing these three distinct wireless networking devices, the Networking Selection Module provides students with a comprehensive understanding of the trade-offs and capabilities of different wireless technologies. This knowledge equips them with the skills necessary to choose the most suitable networking solution for specific application scenarios, adhering to the standards expected in scientific research.

G. Internet Connectivity Selection Module

The Internet Connectivity Selection Module is an essential component of the platform, aimed at providing students with a comprehensive understanding of various network communication technologies and enabling them to engage in real-world network communication processes. This module incorporates four commonly used gateway devices for cloud platform interoperability: GPRS, 4G, NB-IOT, and WIFI. GPRS (General Packet Radio Service) is chosen for its low-power and low-cost connectivity. It allows devices to connect to the internet in a power-efficient manner, making it suitable for applications that require extended battery life. Moreover, its affordability makes GPRS an attractive option for resource-constrained environments. For applications that demand fast and wide coverage transmission, the platform integrates 4G connectivity. 4G offers high-speed internet access and is capable of providing reliable and fast data transmission over large distances, catering to scenarios where quick and seamless connectivity is essential. NB-IOT (Narrowband Internet of Things) is selected for its low-power and wide coverage transmission capabilities. This technology is optimized for connecting a massive number of low-power devices over a wide area, making it suitable for applications such as smart cities, industrial automation, and agriculture. The platform also incorporates WIFI connectivity to provide students with hands-on experience in low-cost and flexible internet connectivity. WIFI is widely adopted and allows for high-speed data transmission and easy network setup. It is commonly used in various everyday devices and is an important technology for IoT applications in homes, offices, and public spaces. By integrating these four diverse gateway devices, the Internet Connectivity Selection Module offers students a comprehensive understanding of the characteristics, advantages, and trade-offs of different network communication technologies. This knowledge empowers them to select the

most appropriate internet connectivity solution based on specific application requirements. Thus, the module meets the rigorous standards expected in scientific research.

H. Human-Machine Interaction Display

The Intelligent Internet of Things (IoT) Comprehensive Training and Assessment Platform has developed a human-machine interaction display using Visual TFT software. It enables network topology selection, real-time experiment result monitoring, data acquisition, processing, storage, and testing functions [16]. The interface of the human-machine interaction display is shown in Figure 6. Component ① represents the main interface of the human-machine interaction display, including four major functional modules: Data Visualization, Network Topology, Settings, and User Manual. Component ② is the Data Visualization interface, which provides real-time visualization of experimental data, facilitating student recording, data analysis, and comprehension of the experimental process and results. Component ③ is the Network Topology interface, where students can send commands to the Multi-Source Dynamic Power Module, which then forwards the parsed commands to the 16-channel Relay Controller Module to control the power supply of the Transducer Access Module, Microcontroller Selection Module, Networking Selection Module, and Internet Connectivity Selection Module. Students have the freedom to choose the power supply for devices, ensuring convenience and flexibility. The system also supports modular power supply to prevent co-frequency interference and device damage caused by instantaneous high power consumption [17]. Component ④ is the Settings interface, allowing control of indicator lights and backlight brightness, while providing data backup functionality for convenient experiment report writing. Component ⑤ is the User Manual interface, offering three modules: Knowledge Framework, Technical Manuals, and Classic Cases, facilitating student reference and consultation.



Figure 6: Human-Machine Interaction Display Interface

Note: Numbered components ①-⑤ correspond to the main interface, data visualization interface, network topology interface, settings interface, and user manual interface of the human-machine interaction display.

IV. DEVELOPMENT AND CASE ANALYSIS OF TRAINING ASSESSMENT PROJECTS BASED ON CLOUD PLATFORM

A. Training Assessment Project Setup

The platform offers diverse training cases to help students explore and learn from a wide range of technical fields. Each training case simulates real-world scenarios, enabling students to better understand the practical process of developing IoT-related products. Table 2 provides a list of different training projects, each with specific sensors, interface protocols, networking technologies, internet connectivity technologies, and access platforms.

B. Case Study on Comprehensive Air Quality Index Detection in Practical Training

The Intelligent Connected Access Comprehensive Practical Training Assessment Platform provides a cloud platform development tool. Students first utilize this tool to design a cloud platform dashboard. Once the design is completed, students can use this cloud platform for experiments and upload experimental data to the cloud platform. Additionally, students can utilize the tools and functionalities provided by the cloud platform to visualize and analyze the uploaded data. Through data visualization, students can observe and analyze experimental results more intuitively, extract valuable information from sensor data, and conduct further data analysis and research. After a series of instructional courses, in order to enhance students' practical operational abilities, a practical training

session is specifically arranged. Taking comprehensive air quality index detection as an example, the main objective of this practical training is to help students comprehensively grasp the basic principles and implementation methods of air quality detection, data acquisition and analysis, and Internet of Things technology. In the training, we have established training assessment points at the University of Sanya Experimental Center, Huangjia Yunshui, and Yantai Mountain. Students will visit these three locations and use various sensors for data collection of air quality-related parameters, and visualize the collected data on the cloud platform. Through this series of steps, six air quality indicators can ultimately be displayed on the cloud platform, as shown in Figure 7. This practical training session not only emphasizes the imparting of theoretical knowledge but also places a stronger emphasis on cultivating practical operational abilities. This will contribute to improving students' comprehensive qualities and professional skills, laying a solid foundation for future scientific research or practical work.

Table 2: Logic Mapping Table of the Communication Converter Board

Case Name	Sensor Selection	Interface Protocol	Networking Technology	Internet Connectivity Technology	Access Platform
RS485 Bus-Based Temperature and Humidity Detection Case	SHT30	RS485	--	4G	USR Cloud
OneWire-based temperature sensing case	DS18B20	OneWire	Zigbee	NB-IOT	Aliyun Cloud
SPI-Based Pressure Detection Training Case	BMP280	SPI	Bluetooth	Wifi	ONEnet
I2C-Based Three-Axis Gyroscope Training Case	MPU6050	IIC	LORA	4G	USR Cloud
UART-Based Laser Ranging Case	TOFSense	UART	LORA	GPRS	--
AD-Based Analog Signal Acquisition Training Case	4-20mA Signal Generator	AD	--	--	--
Hall Sensor-Based Motor Speed Detection Training Case	NJK-5001	Counter	--	--	--
IoT-Based Comprehensive Air Quality Index Detection Training Case	Multi-Parameter Air Quality Detection Module	RS485	LORA	4G	USR Cloud



Figure 7: Cloud-based Large Display for Monitoring Comprehensive Air Quality Indices

V. CONCLUSION

The designed Intelligent Connected Access Comprehensive Practical Training Assessment Platform in this study aims to meet industry demands and cultivate highly qualified talents that align with the requirements of enterprises. To achieve this goal, the integration of industry and education is emphasized, combining practical teaching with industry demands to jointly promote talent development. This platform integrates full-stack technologies such as sensor principles, communication protocol integration, microcontroller programming, networking, connected access, and cloud platform development. It utilizes actual devices used in enterprises to

enhance students' technical application, practical, and innovative abilities, enabling them to master the full-stack technologies related to intelligent connected access and adapt to industry demands. Furthermore, through practical training assessments, this platform contributes to a more comprehensive evaluation of students' learning outcomes and further enhances their comprehensive qualities and professional skills. The platform emphasizes fostering students' proactiveness and innovation capabilities, enabling them to better adapt to industry demands.

ACKNOWLEDGMENT

This paper was supported by Research Project on Higher Education Teaching Reform in Hainan Province. (Hnjg2023ZD-48) and National Undergraduate Training Program for Innovation and Entrepreneurship. (202313892012).

REFERENCES

- [1] Gao, C., Yang, B., & Guo, J. (2023). Exploration of Innovative Entrepreneurship Practice Teaching and Training Mode in the Context of New Engineering Education. *Industrial Innovation Research*, (22), 190-192.
- [2] Wang, Y. (2023). Research on the Talent Cultivation Path of New Type R&D Institutions in Universities with Cooperative Collaboration of Soft and Hard Resources. *China Higher Education Science and Technology*, (11), 32-36. DOI: 10.16209/j.cnki.cust.2023.11.004
- [3] Innovation Talent Project Team of Chinese Academy of Engineering. (2010). Towards Innovation: Research on the Cultivation of Innovative Engineering and Technological Talents. *Research on Higher Engineering Education*, (01), 1-19.
- [4] Chen, H., Liu, B., & Zheng, K. (2018). Research on the Construction of Software Course Group Based on Complex Engineering. In *Proceedings of the 2018 2nd International Conference on Advanced Education and Management Science (AEMS 2018)*. Beijing University of Technology.
- [5] Liu, X., Zhang, Y., Feng, G., et al. (2022). Exploration and Practice of Applied Talent Cultivation Mode in Local Universities under the Background of New Engineering Education: A Case Study of Xinxiang University. *Journal of Management*, 35(02), 136-145. DOI: 10.19808/j.cnki.41-1408/f.2022.0020
- [6] Li, B., Chai, X., Liu, Y., et al. (2022). Research on Empowering Intelligent Manufacturing with Information and Communication Technologies in Industrial Environment. *Chinese Engineering Science*, 24(02), 75-85.
- [7] Cheng, X., Xu, Z., & Zhang, K. (2021). Design of Smart Home Control System Based on Internet of Things. *Sensors and Microsystems*, 40(03), 106-108+111. DOI: 10.13873/J.1000-9787(2021)03-0106-03
- [8] Daowang, L. (2022). Construction of School-Enterprise Cooperation Practice Teaching System under the Big Data Internet of Things Industry Collaborative Innovation Platform. *Computational Intelligence and Neuroscience*, 2022, 20222072434-2072434.
- [9] Dong, L., Hu, H., & Feng, X. (2019). Research on Remote Simulation Experiment Technology Based on GPRS-DTU and Configuration King. *Experimental Science and Technology*, 17(05), 17-21.
- [10] Cui, Y., Zhang, Q., Wu, G., et al. (2020). Research on Wireless Access Technology for Energy Internet Terminal. *Electric Power Information and Communication Technology*, 18(03), 1-7. DOI: 10.16543/j.2095-641x.electric.power.ict.2020.03.001
- [11] Wang, X., Wang, J., Zhang, L., et al. (2023). Exploration of Alibaba Cloud Internet of Things Featured Course Group Teaching Based on OBE Concept. *Educational and Teaching Forum*, (10), 109-112.
- [12] [12] Zhu, Y., & Zhang, X. (2021). Construction and Practice of Engineering Training and Cultivation System Based on New Engineering Education. *Experimental Technology and Management*, 38(01), 8-11. DOI: 10.16791/j.cnki.sjg.2021.01.002
- [13] R, B. M. P., R, K. V., Gowda, N. D., et al. (2019). IoT Based Home Automation System over Cloud. *Journal of Trend in Scientific Research and Development*, 3(4), 966-968.
- [14] Peng, X., Xing, X., & Zeng, H. (2017). Intelligent Breeding System Based on the OneNet Internet of Things Cloud Platform. *Modern Computer (Professional Edition)*, (31), 65-70.
- [15] Wang, C., & Yang, Q. (2019). Design of CPCI+STM32 Architecture Multifunctional Multi-interface Communication Board. *Single-Chip Microcomputer and Embedded Systems Application*, 19(04), 40-45.
- [16] Bai, J., Wang, Y., Zhao, Z., et al. (2023). Research on the Construction of Intelligent Power Grid Regulation System Based on Cloud Computing. *Automation and Instrumentation*, (10), 122-125+130. DOI: 10.14016/j.cnki.1001-9227.2023.10.122
- [17] Zhang, H., Liu, X., Ren, Y., et al. (2019). Feasibility Study of Narrowband Internet of Things for Electric Information Acquisition System. *Electric Measurement and Instrumentation*, 56(06), 82-86. DOI: 10.19753/j.issn1001-1390.2019.06.014