

This article focuses on the physical realization of SVC, TCSC, combined SVC and TCSC scale down models, which have been realized in the laboratory, developed and tested and presented the experimental results. These practical test results have been proven the effectiveness of these devices with closed loop control systems developed with microcontrollers. The voltage stability can be assessed accurately using stability indices. These indices can either reveal the critical bus or line of a power system. The said indices plays vital role in identifying the most critical n-1 and n-2 contingencies. This article further focuses on optimization of these devices in IEEE 9 bus, 14 bus and 30 bus test systems using stability indices and Particle Swarm Optimization (PSO). The simulation results for all these systems have been presented and which proves the tremendous improvement in voltage stability of power systems.

Keywords: SVC, TCSC, Generator Stability, Voltage Stability, Coordination Control of SVC and TCSC, large scale power systems, Stability Improvement.

1. Introduction

In modern power systems stability and secured operation is a vital concern for power engineer [1-2]. The may be instability of load or generator and hence load as well generator stability is most concern issues of a secured system [3]. System performance and security can be improved with FACTS devices hence this article focused on physical implementation includes of scale down models viz. development of scale down models of SVC, TCSC and combined SVC and TCSC along with the test systems[4-7]. Contingency ranking based on voltage stability indices Load flow is performed to obtain the contingency ranking, for severe most outage the optimal locations for series and shunt compensations have been identified and by placing at those locations the system performance have been evaluated [8-12].

2. Implementation of scale down models of SVC

Laboratory based implementation of Thyristor Controlled Reactor(TCR),The fundamental current through the TCR, which may not the sinusoidal, the test result is given in the fig.1 and is specified below as a mathematical expression as mentioned below from equation (1) to equation (5).

$$B_{TCR} = B_L ((\pi-2\alpha-\sin\alpha)/\pi) \quad (1)$$

$$I_{TCR} = V * B_{TCR} \quad (2)$$

* Corresponding author: Venu Yarlagadda, Electrical and Electronics Engineering, VNR Vignana Jyothi Institute of Engineering and Technology, Hyderabad, India 500090 E-mail: venu_y@vnrvjiet.in

¹ Department of Electrical and Electronics Engineering, VNR Vignana Jyothi Institute of Engineering and Technology, Hyderabad

² Department of Electrical and Electronics Engineering, Joginapally B. R. Engineering College, Hyderabad, India 500034

³ Department of Information Technology, VNR Vignana Jyothi Institute of Engineering and Technology, Hyderabad

$$\text{The current through the SVC is } I_{SVC} = j B_{SVC} \quad (3)$$

$$\text{The susceptance of SVC is } B_{SVC} = B_{TSC} - B_{TCR} \quad (4)$$

$$\text{Q injected by the SVC is } Q_{SVC} = VI_{SVC} \quad (5)$$

2.1 Physical Implementation of 1-ph SVC

SVC schematic circuit is shown in fig.1, it is a parallel combination of FC and TCR. TCR delay angle can be controlled from 0-90° or 90° to 180°, thus the reactive power of TCR can be controlled [12-15]. The physical implementation of SVC has been done using LPC2148 microcontroller connected to a synchronous machine of 5KVARating, which is feeding the load. The voltage is decayed to 195 voltage sag against the variation of load .Closed loop control of SVC is achieved with LPC 2148 Microcontroller.

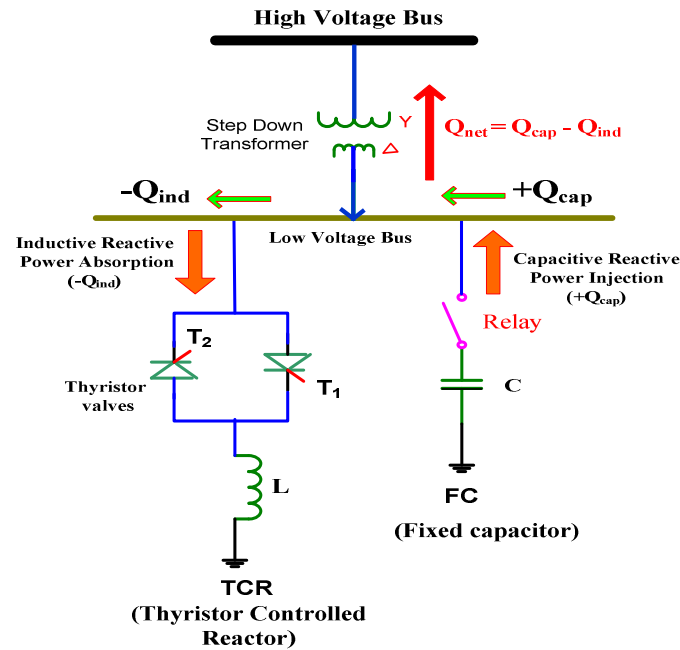

Fig.1. SVC schematic circuit

The voltage characteristics against load variation have been obtained. The one line diagram of developed model has shown in fig.2, corresponding connection circuit is depicted in fig.3 and fig.4 illustrates SVC's control circuit developed by LPC2148 Microcontroller [10-15]

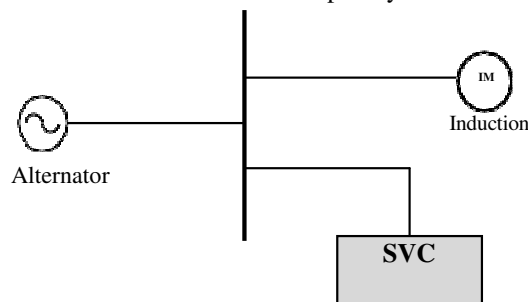

Fig.2. Synchronous Machine with SVC

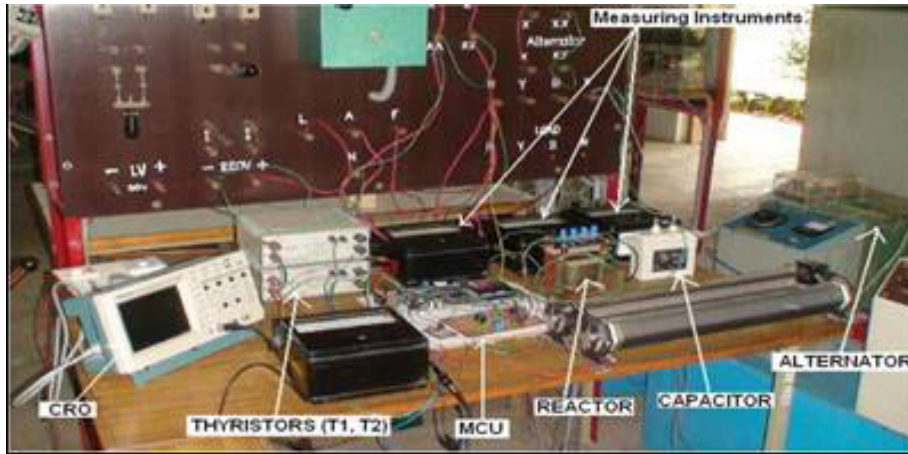

Fig.3. Physical Implementation of SVC in the laboratory.

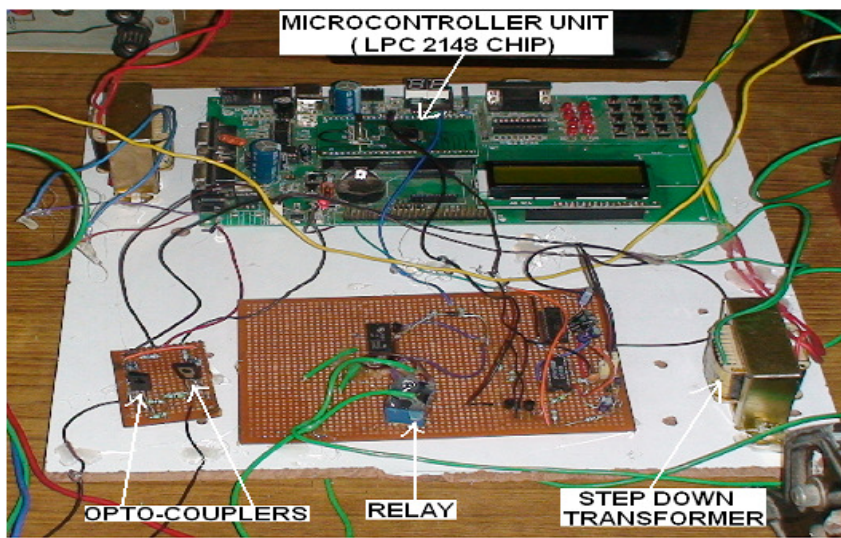

Fig.4. SVC's LPC2148 Microcontroller based control circuit

The testing results have been described in the following tables and figures; table.1 depicts results without SVC and table.2 depicts results with SVC. Fig.5. shows the load voltages against power and fig.6. Power angle curves with power. All these results showing the effectiveness of SVC on system performance, improvement in the terminal voltage and load stability and voltage regulation shown in voltage bar plot. The generator steady state stability and power injection by the generator have been improved to considerable extent [8] to [16].

Table.1. Terminal voltage and power angle without SVC

S. No	V Volts	Line I in A	P Watts	δ in degree
1.	230	3.4	320	11.61
2.	225	3.8	360	13.38
3.	220	4.2	480	18.37

4.	205	4.8	560	23.19
5.	195	5.2	630	27.69
6.	190	6.0	700	31.91

Table.2. Terminal voltage and power angle with SVC

S.No	V Volts	Line I in A	P Watts	δ in degree
1.	235	3.0	280	9.93
2.	232	3.2	300	10.78
3.	230	3.6	440	16.05
4.	230	4.2	500	18.3
5.	230	4.8	580	21.34
6.	225	5.2	650	25.79

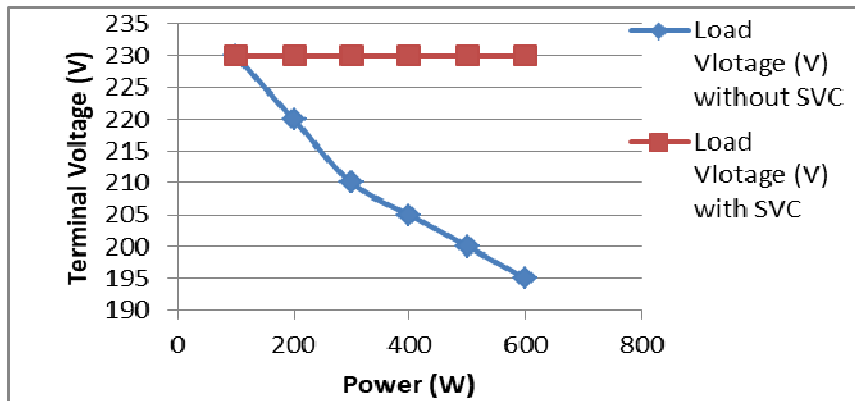

Fig.5. P-V Curves of test system

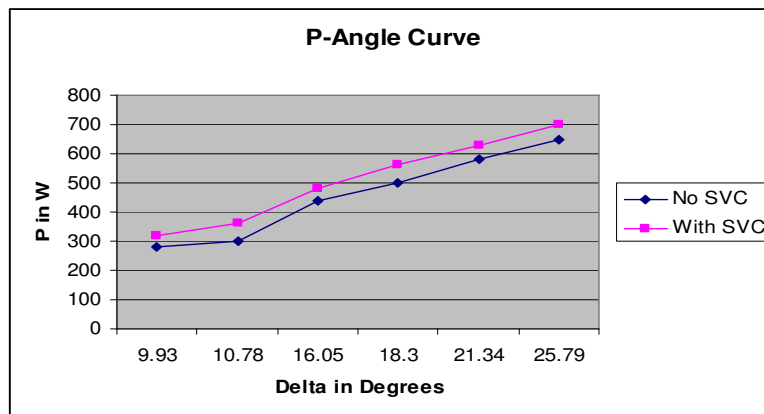

Fig.6. P- δ Curves of test system

3. IEEE 14 bus test model

Fig 7. shows the single line diagram of IEEE 14-bus system. The test system is simulated with MATLAB Programming using Newton-Raphson method of load flow

study. By using line stability indices viz. FVSI & L_{mn} indices, n-1 contingency ranking table is drawn.

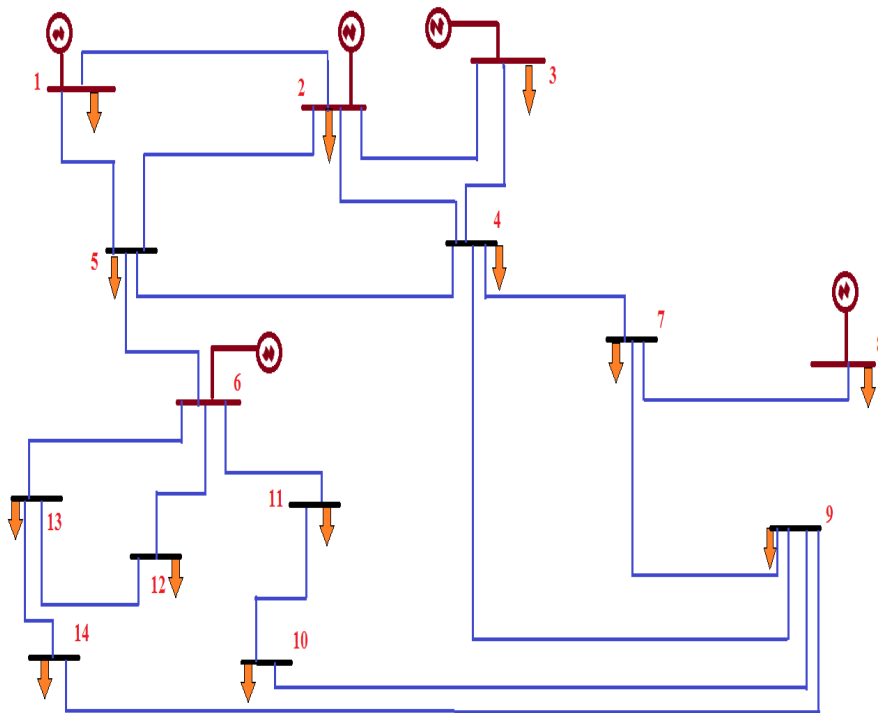

Fig.7. Single line diagram of IEEE 14 bus system

PSO method is used for optimization of shunt compensation. Fig.7 shows the IEEE 14 Bus system and fig 8 shows the PSO Optimization Flowchart.

3.1. Particle swarm optimization

Particle swarm optimization (PSO) is an Artificial intelligence technique, Optimizes a problem iteratively by searching the search space for the optimal solution. Each element in the search space considered as particle (candidate solution), and in each iteration local best updated by comparing to the desired solution and moving these particles in the search space by the mathematical formula for position and velocity of the particle. Each particle best position successively updated in global best in each search. This swarm is expected to move toward the best solution and Fig.8. Illustrates the PSO Optimization Flow chart.

3.2 Algorithm

PSO implementation requires the search space containing particles as the candidate solutions and these particles updated in each iteration to find the desired solution.

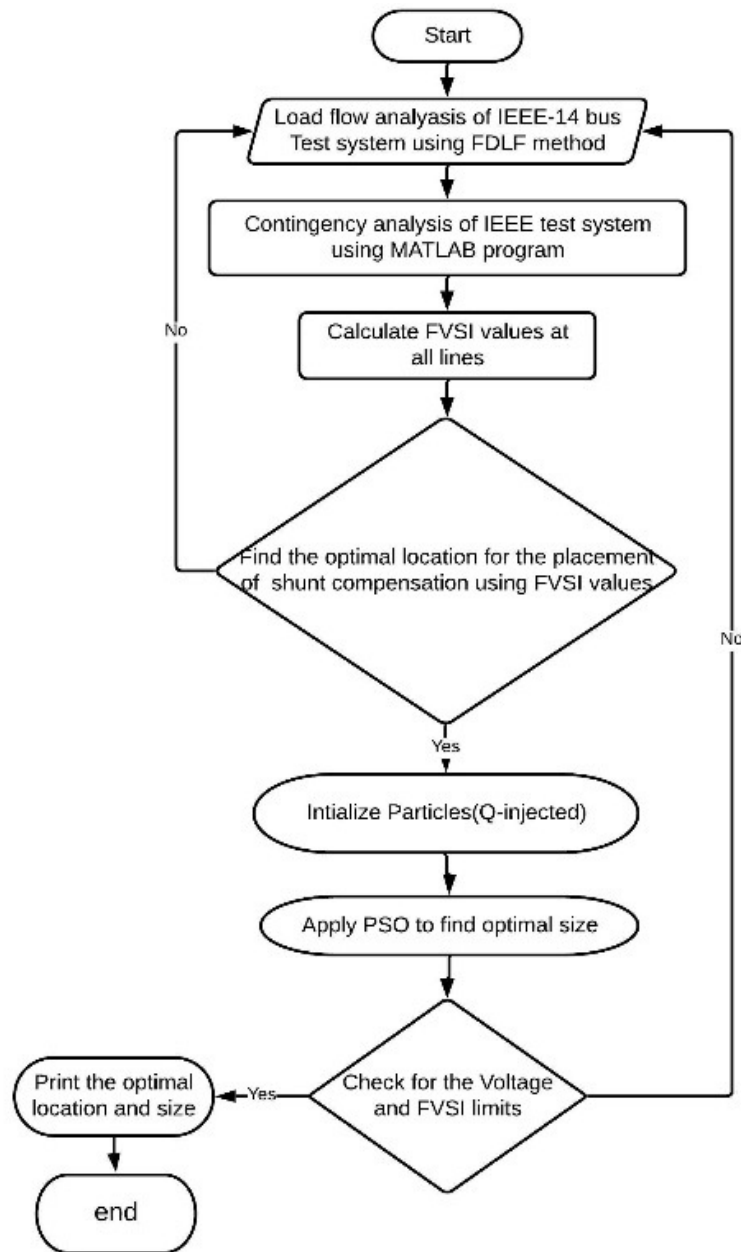

Fig.8. PSO Optimization Flowchart

Find search space (particles $k=1 \dots n$)
forevery candidate (particle) $k= 1, \dots, n$ **do**
 Initialize the each candidate position with random value from the random vector: $\mathbf{x}_k \sim U(\mathbf{b}_{l0}, \mathbf{b}_{up})$
 Initialize the each candidate best known position to its initial position: $\mathbf{p}_k \leftarrow \mathbf{x}_k$
if $f(\mathbf{p}_k) < f(\mathbf{g})$ **then**
 update the search space best updated position: $\mathbf{g} \leftarrow \mathbf{p}_k$
 Initialize the candidate velocity: $\mathbf{v}_i \sim U(-|\mathbf{b}_{up}-\mathbf{b}_{l0}|, |\mathbf{b}_{up}-\mathbf{b}_{l0}|)$

While desired solution is not yet met **do**:
for each candidate $k= 1, \dots, n$ **do**
for each dimension $d= 1, \dots, n$ **do**
 Pick random numbers: $r_p, r_g \sim U(0,1)$
 Update the candidate velocity: $\mathbf{v}_{k,d} \leftarrow \omega \mathbf{v}_{k,d} + \phi p r_p (\mathbf{p}_{k,d} - \mathbf{x}_{k,d}) + \phi g r_g (\mathbf{g}_d - \mathbf{x}_{k,d})$
 Update the candidate position: $\mathbf{x}_k \leftarrow \mathbf{x}_k + \mathbf{v}_k$
If $f(\mathbf{x}_k) < f(\mathbf{p}_k)$ **then**
 Update the candidate best known position: $\mathbf{p}_k \leftarrow \mathbf{x}_k$
if $f(\mathbf{p}_k) < f(\mathbf{g})$ **then**
 Update the search space best known position: $\mathbf{g} \leftarrow \mathbf{p}_k$

Each iteration updates the velocity of the particle which here considered as the Reactive power at each vulnerable buses in the system and velocity of each particle is updated depending upon the objective function defined above. P is the local best in each iteration and by assigning p values solution is found. In each iteration best possible solution is assigned to the g which is the global best and final optimal solution will be the f(g). Fig.9. illustrates the Voltage Bar graphs of IEEE-14 Bus test system (series, shunt& Coordination) and Fig.10 illustrates the FVSI Bar graphs of IEEE-14 Bus test system (series, shunt & Coordination)

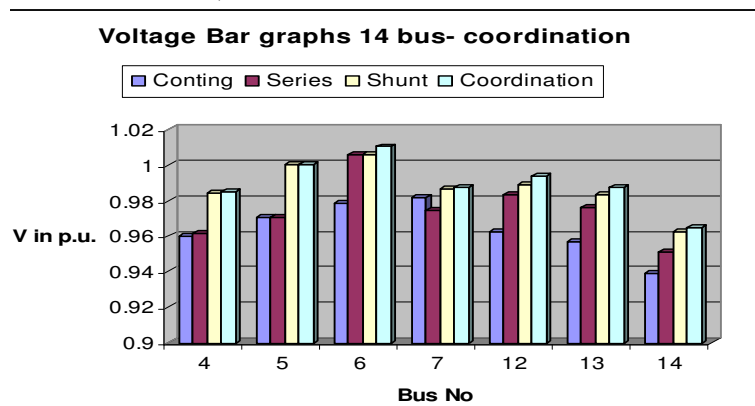

Fig.9. Voltage Bar graphs of IEEE-14 Bus test system (series, shunt& Coordination)

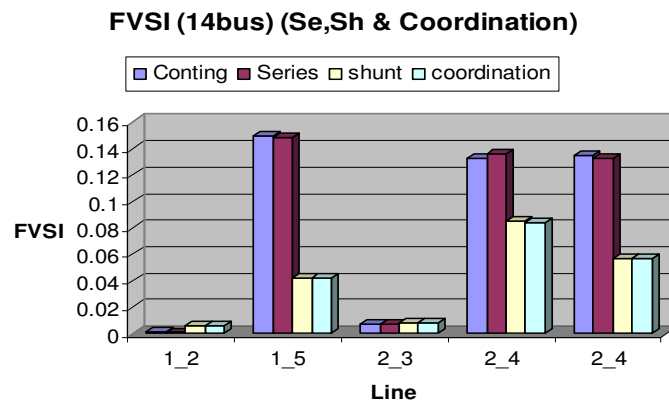

Fig.10. FVSI Bar graphs of IEEE-14 Bus test system (series, shunt & Coordination)

4. IEEE 30-Bus Test System

Fig.11. Shows the single Line Diagram of IEEE 30 Bus Test System, Fig 12. Illustrates the V-L-index and VCPI Bar graphs (Base Case), Fig 13 shows the V-L-index and VCPI Bar graphs (Critical Contingency), Fig 14. Illustrates the Voltages for Contingency, Series, Shunt and Co-ordination Controls, Fig 15 illustrates the L-index for Contingency, Series, Shunt and Co-ordination Controls and Fig 16 depicts the FVSI for Contingency, Series, Shunt and Co-ordination Controls

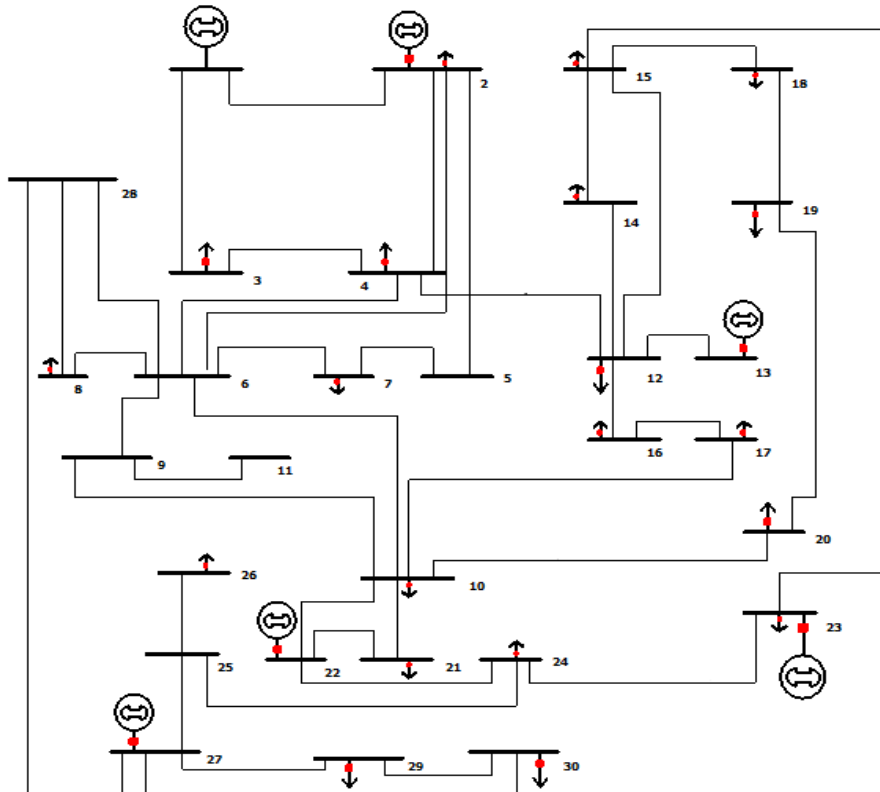

Fig.11. Single Line Diagram of IEEE 30 Bus Test System

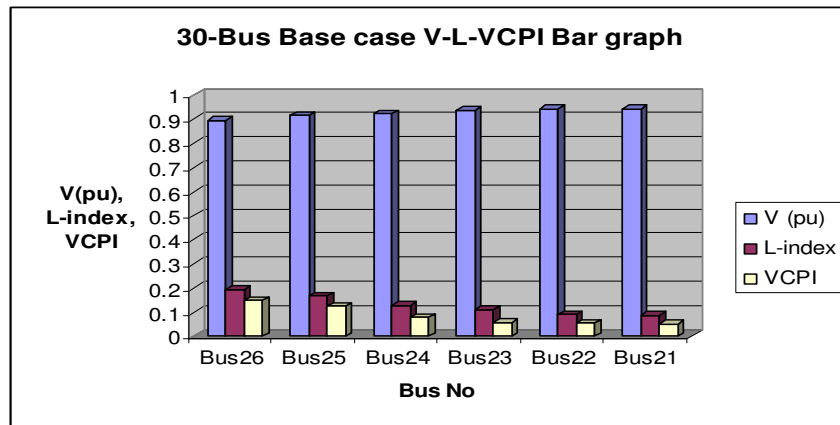

Fig 12. V-L-index and VCPI Bar graphs (Base Case)

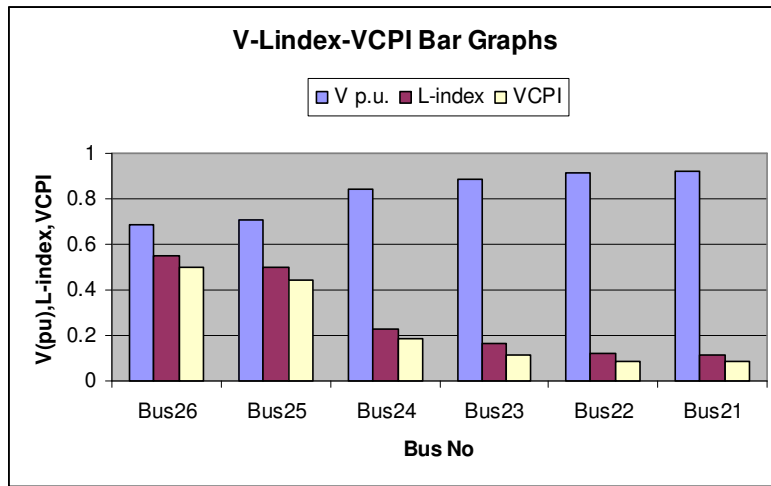

Fig 13. V-L-index and VCPI Bar graphs (Critical Contingency)

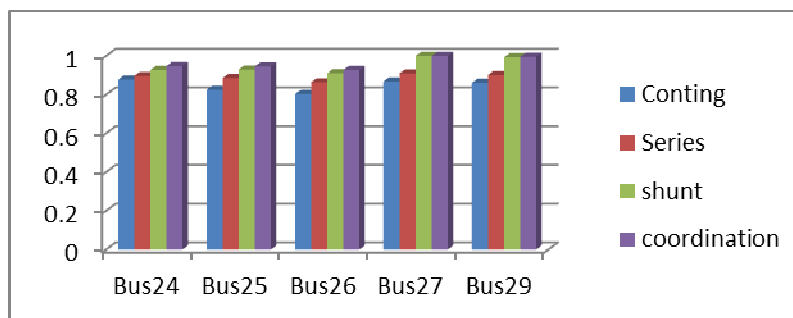

Fig 14. Voltages for Contingency, Series, Shunt and Co-ordination Controls

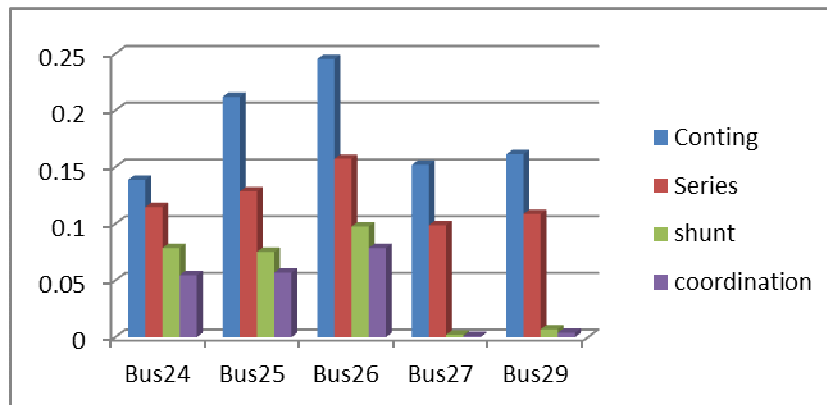

Fig 15. L-index for Contingency, Series, Shunt and Co-ordination Controls

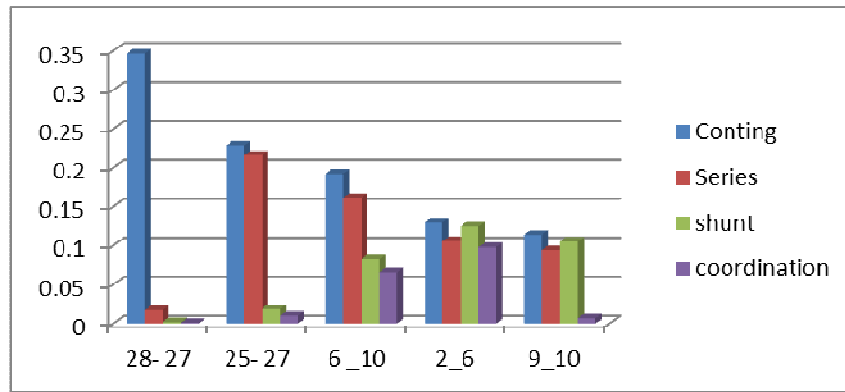

Fig 16. FVSI for Contingency, Series, Shunt and Co-ordination Controls

5. Conclusion

The test results of the small scale laboratory based physical working models of single phase SVC, three phase SVC, TCSC, Combined TCSC and SVC have shows that all of these controllers have significant improvement in system performance. Among these controllers, TCSC has plays a dominant role power flow control where as SVC has significant role in voltage control and lastly the combined TCSC and SVC compensator has both of these dominant features and hence it is suggested that combined or coordinated control of series and shunt compensators are more advantageous than individual controllers. The final result shows the effectiveness of FVSI and Particle Swarm Optimization methods on voltage stability improvement of interconnected power systems.

References

- [1] N.G. Hingorani and L. Gyugyi, Understanding FACTS, IEEE Press, New York, USA, 1999.
- [2] R.M. Mathur and R.K. Varma, Thyristor-Based FACTS Controllers for Electrical Transmission Systems, IEEE Press and Wiley Interscience, New York, USA, Feb. 2002.
- [3] IEEE Power Engg. Society/CIGRE, "FACTS Overview", Publication 95 TP 108, IEEE Press, New York, 1995
- [4] P. Kundur, Power System Stability and Control, McGraw-Hill, Inc., New York, 1994.
- [5] IEEE Power Engineering Society, "FACTS Applications", Publication 96 TP 116-0, IEEE Press, New York, 1996
- [6] W.A.Lyon, Transient Analysis of Alternating Current Machinery, Chapter 2, John Wiley, New York, 1954.
- [7] Taufik and Bryan Paet are presented "A small scale Static VAR Compensator (SVC) for Laboratory Experiment". IEEE Press, India, 2009.
- [8] T. Ahmed, K. Nishida, K. Soushin and M. Nakaoka are presented "Static VAR compensator-based voltage control implementation of single-phase self-excited induction generator". IEEE Press, India, 2008
- [9] A Thyristor Controlled Series Capacitor Design For Research Laboratory Application, Ieee 1999, 903 - 908 Vol.2 Rigby, B.S.; Ndlovu, C.K.; Harley,R.G.; Sch. Of Electr. & Electron. Eng., Natal Univ., Durban.
- [10] Yarlagadda, V., Karthika, G.A., Ambati, G., Kumar, C.S. (2022). Wind Energy System Using Self Excited Induction Generator with Hybrid FACTS Device for Load Voltage Control. In: Mekhilef, S., Shaw, R.N., Siano, P.(eds) Innovations in Electrical and Electronic Engineering. ICEEE 2022. Lecture Notes in Electrical Engineering, vol 893. Springer, Singapore. https://doi.org/10.1007/978-981-19-1742-4_6.
- [11] Yarlagadda, V., Haripriya, T., Amarnath Reddy, N., Ambati, G. (2022). Transient Response and Stability Analysis of Weak Power System Using Hybrid Compensator, STATCOM and

- SVC:A Comprehensive comparison. In: Mekhilef, S., Shaw, R.N., Siano, P. (eds) *Innovations in Electrical and Electronic Engineering*. ICEEE 2022. Lecture Notes in Electrical Engineering, vol 893. Springer, Singapore. https://doi.org/10.1007/978-981-19-1742-4_4
- [12] Venu Yarlagadda, B.V.Sankar Ram, .K.R.M.Rao, “Design And Implementation Of Synchronous Phase Modifier (Spm) And Finding Its Optimal Location In Power Systems For Voltage Stability Improvement”-International Conference On Electrical And Electronics Engineering ICEEE On 22-04-2012 At Coimbatore, India, Proceedings Pp – 44-48.
- [13] Yarlagadda, V., Karthika, G.A., Ambati, G., Kumar, C.S. (2022). Wind Energy System Using Self Excited Induction Generator with Hybrid FACTS Device for Load Voltage Control. In: Mekhilef, S., Shaw, R.N., Siano, P. (eds) *Innovations in Electrical and Electronic Engineering*. ICEEE 2022. Lecture Notes in Electrical Engineering, vol 893. Springer, Singapore. https://doi.org/10.1007/978-981-19-1742-4_6
- [14] Venu Yarlagadda, NireekshanaTuraka, Giri Prasad Ambati, S Poornima “Optimization of Voltage Stability based Shunt and Series Compensation using PSO” *Design Engineering Vol2021, Issues 7, Pages 8679–8694*
- [15] Yarlagadda, V., Kapoor, R., Kumar, C.S., Ambati, G. (2022). Dynamic and Transient Stability Enhancement of Multi Area Power Systems Using Fuzzy Logic Control Against Load Disturbances. In: Mekhilef, S., Shaw, R.N., Siano, P. (eds) *Innovations in Electrical and Electronic Engineering*. ICEEE 2022. Lecture Notes in Electrical Engineering, vol 893. Springer, Singapore. https://doi.org/10.1007/978-981-19-1742-4_2

© 2023. This work is published under
<https://creativecommons.org/licenses/by/4.0/legalcode>(the“License”).
Notwithstanding the ProQuest Terms and Conditions, you may use this
content in accordance with the terms of the License.